

Operating and Programming Manual

HP 8560A/8561B/8563A Portable Spectrum Analyzers



HP Part No. 5960-6561 Microfiche Part No. 5960-6565
Printed in USA November 1991

Certification

Hewlett-Packard Company certifies that this product met its published specifications at the time of shipment from the factory. Hewlett-Packard further certifies that its calibration measurements are traceable to the United States National Institute of Standards and Technology, to the extent allowed by the Institute's calibration facility, and to the calibration facilities of other International Standards Organization members.

Warranty

This Hewlett-Packard instrument product is warranted against defects in material and workmanship for a period of one year from date of shipment. During the warranty period, Hewlett-Packard Company will, at its option, either repair or replace products which prove to be defective.

For warranty service or repair, this product must be returned to a service facility designated by Hewlett-Packard. Buyer shall prepay shipping charges to Hewlett-Packard and Hewlett-Packard shall pay shipping charges to return the product to Buyer. However, Buyer shall pay all shipping charges, duties, and taxes for products returned to Hewlett-Packard from another country.

Hewlett-Packard warrants that its software and firmware designated by Hewlett-Packard for use with an instrument will execute its programming instructions when properly installed on that instrument. Hewlett-Packard does not warrant that the operation of the instrument, or software, or firmware will be uninterrupted or error-free.

LIMITATION OF WARRANTY

The foregoing warranty shall not apply to defects resulting from improper or inadequate maintenance by Buyer, Buyer-supplied software or interfacing, unauthorized modification or misuse, operation outside of the environmental specifications for the product, or improper site preparation or maintenance.

NO OTHER WARRANTY IS EXPRESSED OR IMPLIED. HEWLETT-PACKARD SPECIFICALLY DISCLAIMS THE IMPLIED WARRANTIES OF MERCHANTABILITY AND FITNESS FOR A PARTICULAR PURPOSE.

EXCLUSIVE REMEDIES

THE REMEDIES PROVIDED HEREIN ARE BUYER'S SOLE AND EXCLUSIVE REMEDIES. HEWLETT-PACKARD SHALL NOT BE LIABLE FOR ANY DIRECT, INDIRECT, SPECIAL, INCIDENTAL, OR CONSEQUENTIAL DAMAGES, WHETHER BASED ON CONTRACT, TORT, OR ANY OTHER LEGAL THEORY.

Assistance

Product maintenance agreements and other customer assistance agreements are available for Hewlett-Packard products.

For any assistance, contact your nearest Hewlett-Packard Sales and Service Office.

HP 856X Spectrum Analyzer Documentation Outline

Instruments of the HP 856X family of spectrum analyzers are documented to varying levels of detail. Certain documents cover several instruments and others are unique to an individual instrument. The available documentation is described below.

Manuals Supplied with the Instrument

Installation and Verification Manual

Installation and verification manuals are unique to given instrument. Topics covered by this manual include installation, specifications, verification of spectrum analyzer operation, and what to do if a failure occurs.

Operation and Programming Manual

This is a generic manual applicable to the HP 8560A, HP 8561B, and HP 8563A instruments. Topics include preparation for use, spectrum analyzer functions, and softkey definitions, programming fundamentals and definitions for remote programming commands.

Quick Reference Guide

The Quick Reference Guide is an abbreviated version of the operating and programming manual providing a list of all remote programming commands.

Manuals Available Separately

Service Manual

This manual provides information for servicing an instrument to the assembly level. The manual includes instrument adjustments, troubleshooting, major assembly replaceable parts lists, and replacement procedures. For ordering information, contact a Hewlett-Packard Sales and Service Office. This manual is not always immediately available for new products. Some earlier service manuals are titled *Support Manual*.

Component-Level Information

This manual provides component level information for the assemblies used in the instrument. Schematic drawings, component locators and assembly parts list are provided for the current vintage of assemblies. Component-Level Information is not always immediately available for new assemblies.

Contents

1. Instrument Overview	
The Front Panel	1-1
Display Annotation	1-4
The Rear Panel	1-6
Introducing Menus and Softkeys	1-8
Making a Basic Measurement	1-10
Reference-Level Calibration	1-12
Menu Trees	1-14
2. Function Descriptions	
Fundamental Functions	2-2
Frequency	2-3
Span	2-5
Amplitude	2-7
Hold	2-12
Instrument State Functions	2-13
Preset	2-14
Configuration	2-15
Calibration	2-19
Auxiliary Control	2-22
HP 8560A Option 002	2-26
AUX CTRL Softkey Menus continued	2-31
Copy	2-43
Module	2-44
Save	2-45
Recall	2-48
Measure	2-51
Adjacent Channel Power (ACP) Instrument Setup	2-58
Adjacent Channel Power (ACP) Computations	2-59
Single Sweep	2-61
Marker Functions	2-62
Marker Priority	2-62
Marker	2-63
Marker ->	2-65
Normal Marker Functions	2-65
Delta Marker Functions	2-65
Frequency Counter	2-67
Peak Search	2-69
Control Functions	2-72
Sweep	2-73
Bandwidth	2-74
Trigger	2-76

Auto Couple	2-77
Trace	2-79
Display	2-83
3. Common Measurements	
Example 1: Harmonic Distortion	3-1
What Is Harmonic Distortion?	3-1
Spectrum Analyzer Functions Used	3-1
Stepping through the Fast Harmonic Measurements	3-2
Alternative Measurement Method	3-4
Percent of Harmonic Distortion	3-6
Example 2: Third-Order Intermodulation Distortion	3-7
What Is Intermodulation Distortion?	3-7
Spectrum Analyzer Functions Used	3-7
Stepping through the Measurement	3-7
Example 3: AM and FM Demodulation	3-11
Introduction	3-11
Spectrum Analyzer Functions Used	3-11
Stepping through the Measurement	3-11
Example 4: Stimulus-Response Measurements	3-13
What Are Stimulus-Response Measurements?	3-13
Spectrum Analyzer Functions Used	3-13
Stepping through the Measurement	3-14
Example 5: External Millimeter Mixers (unpreselected)	3-23
Spectrum Analyzer Functions Used	3-23
Stepping through the Measurement	3-23
Example 6: Adjacent Channel Power Measurement	3-30
What is Adjacent Channel Power (ACP)?	3-30
Spectrum Analyzer Functions Used	3-30
Stepping through the Measurement	3-30
4. Programming	
Setup Procedure	4-2
Communication with the System	4-3
Executing Remote Commands	4-3
Syntax Requirements	4-4
Local and Remote Control	4-5
Initial Program Considerations	4-5
Program Timing	4-6
Data Transfer to Computer	4-9
Parameter versus Measurement Units	4-10
Position Units and Trace Elements	4-11
Trace-Data Formatting	4-11
TDF P: Return Decimal Numbers in Parameter Units	4-12
TDF M (M-format): Return Decimal Numbers in Measurement Units (output only)	4-13
TDF B (B-Format): Return Binary Numbers in Measurement Units (output only)	4-14
TDF A (A-block format): Return Absolute Block-Data Fields in Measurement	4-16

TDF I (I-block format): Return Indefinite Block-Data Fields in Measurement	4-18
Transmission Sequence of Data on HP-IB	4-19
Input and Output Buffers	4-20
Benefits of an Output Buffer	4-20
Buffer Space	4-21
Preventing Timeouts	4-21
Synchronizing Your Program	4-21
Clearing the Buffers	4-22
Summary	4-22
Math Functions	4-23
Variables and Traces	4-23
Variables	4-23
Traces	4-23
Math Commands	4-23
Two Rules for Trace Math	4-23
Adding and Subtracting in dBm	4-24
Use AMBPL to Correct Data	4-24
Adding and Subtracting in Volts	4-25
Trace Data Limits	4-26
Creating Screen Titles	4-27
No-Format Method	4-27
Format Methods	4-28
Making a Title in A-Block Format	4-28
Making a Title in I-Block Format	4-28
Generating Plots and Prints Remotely	4-29
Plotter Requirements	4-29
Making a Basic Plot	4-30
Plotting Options	4-31
Printer Requirements	4-32
Making a Basic Print	4-32
Monitoring System Operation	4-33
Interrupt Process	4-33
Analyzer Status Byte	4-34
The Service-Request Mask	4-34
Computer Interrupt Statements	4-35
Reading Service Request Data	4-36
Reading Service Requests From More Than One Instrument	4-37
Testing Service Request Routines	4-37
Summary	4-38
5. Language Reference	
Introduction	5-1
Syntax Diagram Conventions	5-2
Pictorial Notation	5-2
Command Sequence	5-2
Command Sequence Summary	5-2
Query Responses	5-3
Secondary Keywords	5-5
Programming Codes (functional index)	5-8
Programming Commands	5-14

ACPBW Adjacent Channel Power Bandwidth	5-15
ACPCOMPUTE Compute Adjacent Channel Power	5-16
ACPGRAPH Adjacent Channel Power Graph	5-17
ACPLOWER Lower Adjacent Channel Power	5-18
ACPMAX Maximum Adjacent Channel Power	5-19
ACPMEAS Measure Adjacent Channel Power	5-20
ACPPWRTX Total Power Transmitted	5-21
ACPSP Adjacent Channel Power Spacing	5-22
ACPUPPER Upper Adjacent Channel Power	5-23
ADJALL LO and IF Adjustments	5-24
ADJCRT Adjust CRT Alignment	5-25
ADJIF Adjust IF	5-26
AMB Trace A Minus Trace B	5-28
AMBPL Trace A Minus Trace B Plus Display Line	5-29
ANNOT Annotation On/Off	5-31
APB Trace A Plus Trace B	5-32
AT Input Attenuation	5-33
AUNITS Absolute Amplitude Units	5-35
AUTOCP Auto Coupled	5-37
AXB Trace A Exchange Trace B	5-38
BLANK Blank Trace	5-39
BML Trace B Minus Display Line	5-40
CF Center Frequency	5-41
CLRW Clear Write	5-43
CNVLOSS Conversion Loss	5-44
CONTS Continuous Sweep	5-46
COUPLE Input Coupling	5-47
DEMODO Demodulation	5-48
DEMODAGC Demodulation Automatic Gain Control	5-50
DEMODT Demodulation Time	5-51
DET Detection Modes	5-53
DL Display Line	5-55
DONE Done	5-57
ERR Error	5-58
ET Elapsed Time	5-60
EXTMXR External Mixer Mode	5-61
FA Start Frequency	5-62
FB Stop Frequency	5-64
FDIAG Frequency Diagnostics	5-66
FDSP Frequency Display Off	5-68
FFT Fast Fourier Transform	5-69
FOFFSET Frequency Offset	5-71
FREF Frequency Reference	5-73
FS Full Span	5-74
FULBAND Full Band	5-75
GRAT Graticule On/Off	5-77
HD Hold	5-78
HNLOCK Harmonic Number Lock	5-79
HNUNLK Unlock Harmonic Number	5-81
ID Output Identification	5-82
IDCF Signal Identification to Center Frequency	5-83

IDFREQ Signal Identified Frequency	5-84
IP Instrument Preset	5-85
LG Logarithmic Scale	5-88
LN Linear Scale	5-89
MBIAS Mixer Bias	5-90
MINH Minimum Hold	5-92
MKA Marker Amplitude	5-93
MKBW Marker Bandwidth	5-94
MKCF Marker to Center Frequency	5-95
MKD Marker Delta	5-96
MKDR Reciprocal of Marker Delta	5-97
MKF Marker Frequency	5-98
MKFC Frequency Counter	5-99
MKFCR Frequency Counter Resolution	5-100
MKMIN Marker to Minimum	5-102
MKN Marker Normal	5-103
MKNOISE Marker Noise	5-105
MKOFF Marker Off	5-106
MKPK Peak Search	5-107
MKPT Marker Threshold	5-108
MKPX Peak Excursion	5-110
MKRL Marker to Reference Level	5-112
MKSP Marker Delta to Span	5-113
MKSS Marker to Center Frequency Step-Size	5-114
MKT Marker Time	5-115
MKTRACK Signal Track	5-116
ML Mixer Level	5-117
MXMH Maximum Hold	5-118
MXRMODE Mixer Mode	5-119
NORMLIZE Normalize Trace Data	5-120
NRL Normalized Reference Level	5-122
NRPOS Normalized Reference Position	5-124
OP Output Display Parameters	5-126
PLOT Plot Display	5-127
PLOTORG Display Origins	5-128
PLOTSRC Plot Source	5-129
PP Preselector Peak	5-131
PRINT Print	5-132
PSDAC Preselector DAC Number	5-134
PSTATE Protect State	5-135
PWRBW Trace Power Bandwidth	5-136
RB Resolution Bandwidth	5-137
RBR Resolution Bandwidth to Span Ratio	5-139
RCLOSCAL Recall Open/Short Average	5-140
RCLS Recall State	5-142
RCLT Recall Trace	5-143
RCLTHRU Recall Thru	5-144
REV Revision Number	5-146
RL Reference/Range Level	5-147
RLCAL Reference Level Calibration	5-149
ROFFSET Amplitude Reference Offset	5-150

RQS Request Service Conditions	5-151
SAVES Save State	5-153
SAVET Save Trace	5-154
SER Serial Number	5-155
SIGID Signal Identification	5-156
SNGLS Single Sweep	5-157
SP Frequency Span	5-158
SQUELCH Squelch	5-160
SRCALC Source Leveling Control	5-162
SRCCRSTK Coarse Tracking Adjust	5-163
SRCFINTK Fine Tracking Adjust	5-165
SRCPOFS Source Power Offset	5-167
SRCPSTP Source Power Step	5-168
SRCPSWP Source Power Sweep	5-169
SRCPWR Source Power	5-171
SRCTKPK Source Tracking Peak	5-173
SRQ Service Request	5-174
SS Center Frequency Step-Size	5-175
ST Sweep Time	5-177
STB Status Byte Query	5-179
STOREOPEN Store Open	5-180
STORESHORT Store Short	5-182
STORETHRU Store Thru	5-184
SWPCPL Sweep Couple	5-186
SWPOUT Sweep Output	5-187
TDF Trace Data Format	5-188
TH Threshold	5-190
TITLE Title Entry	5-192
TM Trigger Mode	5-193
TRA/TRB Trace Data Input/Output	5-195
TS Take Sweep	5-197
TWNDOW Trace Window	5-198
VAVG Video Average	5-200
VB Video Bandwidth	5-202
VBR Video Bandwidth to Resolution Bandwidth Ratio	5-204
VIEW View Trace	5-206
VTL Video Trigger Level	5-207

A. Instrument Preset State

B. Softkey Cross Reference

C. Key versus Programming Command Cross Reference	
D. Programming Command versus Key	
E. Error Messages	
Eliminating Error Messages	E-1
Recording Error Messages	E-2
Viewing Multiple Messages	E-2
Error Code Listing	E-3
F. Backward-Compatible Commands	
G. Resolution Bandwidth	
Input Signals of Equal Amplitude	G-1
Input Signals of Unequal Amplitude	G-2
H. Modulation	
Amplitude Modulation	H-1
Frequency Modulation	H-3
I. Pulsed RF	
Pulse Mode	I-1
Center Frequency, Sidelobe Ratio, and Pulse Width	I-2
Pulse Repetition Frequency (PRF)	I-4
Peak Pulse Power and Desensitization	I-4
Index	

Figures

1-1. HP 8560A Front Panel	1-1
1-2. Display Annotation	1-4
1-3. HP 8560A Rear Panel	1-6
1-4. Softkey Menu	1-8
1-5. 300 MHz Center Frequency	1-10
1-6. 20 MHz Frequency Span	1-11
1-7. Activated Normal Marker	1-11
1-8. -10 dBm Reference Level	1-12
1-9. Peaked Signal to Reference Level	1-13
2-1. CRT Alignment Pattern	2-20
2-2. Tracking Error	2-30
2-3. Channel Bandwidth Parameters	2-54
2-4. ACP Graph Display	2-56
2-5. PEAK EXCURSN defines the peaks on a trace.	2-70
3-1. Input Signal and Harmonics	3-2
3-2. Peak of signal is positioned at reference level for maximum accuracy.	3-3
3-3. Harmonic distortion measured in dBc. Marker threshold set to -70 dB.	3-3
3-4. Percentage of Distortion versus Harmonic Amplitude	3-4
3-5. Input Signal Displayed in a 1 MHz Span	3-5
3-6. Second Harmonic Displayed in dBc	3-5
3-7. Third-Order Intermodulation Test Setup	3-7
3-8. Signals Centered on Spectrum Analyzer Display	3-8
3-9. Signal Peak Set to Reference Level	3-9
3-10. Intermodulation Distortion Measured in dBc	3-10
3-11. Display with Title	3-10
3-12. AM and FM Demodulation Test Setup	3-11
3-13. FM Band	3-12
3-14. Place a marker on the signal of interest, then demodulate.	3-12
3-15. Block Diagram of a Spectrum Analyzer/Tracking Generator Measurement System	3-13
3-16. Transmission Measurement Test Setup	3-14
3-17. Tracking-Generator Output Power Activated	3-15
3-18. Adjust spectrum analyzer settings according to the measurement requirement.	3-15
3-19. Decrease the resolution bandwidth to improve sensitivity.	3-16
3-20. Manual tracking adjustment compensates for tracking error.	3-17
3-21. Guided calibration routines prompt the user.	3-17
3-22. The thru trace is displayed in trace B.	3-18
3-23. Normalized Trace	3-18
3-24. Measure the rejection range with delta markers.	3-19
3-25. NORM REF LVL adjusts the trace without changing analyzer settings.	3-19
3-26. Increase the dynamic measurement range by using RANGE LVL	3-20
3-27. Normalized Frequency Response Trace of a Preamplifier	3-21

3-28. NORM REF LVL is a trace function.	3-21
3-29. RANGE LVL adjusts analyzer settings for compression-free measurements.	3-22
3-30. External Mixer Setup (a) without Bias; (b) with Bias	3-23
3-31. Select the band of interest.	3-25
3-32. Store and correct for conversion loss.	3-25
3-33. Signal Responses Produced by a 50 GHz Signal in U Band	3-26
3-34. Response for Invalid Signals	3-27
3-35. Response for Valid Signals	3-27
3-36. SIG ID AT MKR Performed on an Image Signal	3-28
3-37. SIG ID AT MKR Performed on a True Signal	3-28
3-38. Adjacent Channel Power Measurement Test Setup	3-30
3-39. Adjacent Channel Power Parameters	3-31
3-40. Adjacent Channel Power Measurement Results	3-32
3-41. ACP Graph Display	3-33
4-1. HP 8560A connected to an HP 9000 Series 300 computer.	4-2
4-2. Invalid Trace Information	4-7
4-3. Updated Trace Information	4-7
4-4. Update trace information with TS before executing marker commands.	4-8
4-5. Data Transferred in TDF M Format	4-14
4-6. Buffer Summary	4-22
4-7. Display Units	4-26
4-8. Screen Titles Appear in the Upper-Right Corner of the Graticule	4-27
4-9. P1 and P2 Coordinates	4-29
5-1. Numeric Value Query Response	5-3
5-2. Binary State Query Response	5-3
5-3. CRT Alignment Pattern	5-25
5-4. MKPX Determines Which Signals are Considered Peaks	5-110
G-1. 1 kHz Signal Separation	G-1
G-2. 2 kHz Signal Separation	G-2
G-3. Bandwidth Shape Factor	G-3
G-4. 100 kHz Bandwidth Resolution	G-3
G-5. 300 kHz Bandwidth Resolution	G-4
H-1. An Amplitude-Modulated Signal	H-1
H-2. Percentage of Modulation	H-2
H-3. A Frequency-Modulated Signal	H-3
H-4. FM Signal with Carrier at a Null	H-3
H-5. FM Signal with First Sidebands at a Null	H-4
H-6. Bessel Functions for Determining Modulation Index	H-4
H-7. FM Deviation Test Setup	H-5
H-8. Markers Show Modulating Frequency	H-6
I-1. Main Lobe and Side Lobes	I-1
I-2. Trace Displayed as a Solid Line	I-2
I-3. Center Frequency at Center of Main Lobe	I-2
I-4. Markers Show Sidelobe Ratio	I-3
I-5. Markers Show Pulse Width	I-3
I-6. Measuring Pulse Repetition Frequency	I-4

Tables

1-1. Front-Panel Connector Data	1-3
2-1. Frequency Bands and Their Minimum Reference Levels	2-7
2-2. Flatness Points and Conversion Losses for Frequencies above 18 GHz	2-34
2-3. Mixing Harmonics for Frequencies above 18 GHz	2-39
3-1. External Mixer Frequency Ranges	3-24
4-1. Units for Returned Data	4-10
4-2. HP-IB Transmission Sequence for Different Trace-Data Formats (TDF)	4-19
4-3. Scaling Points for Various Plotters	4-30
4-4. Status Register	4-34
5-1. Syntax Elements	5-4
5-2. Secondary Keyword Summary	5-5
5-3. External-Mixer Frequency Bands	5-76
5-4. Frequency Bands and the Corresponding LO Harmonic	5-79
5-5. HP 8560A/8561B/8563A Preset State	5-85
5-6. Frequency Ranges and Minimum Reference Level (0 dB Input Attenuation)	5-148
5-7. Status Register	5-151
5-8. Special Printing Characters	5-192
A-5. Instrument State after PRESET Is Executed	A-1
B-1. Softkey Cross Reference	B-2
C-1. Softkey Cross Reference	C-2
D-1. Command versus Key	D-2
H-1. Carrier Nulls and Modulation Indexes	H-4
H-2. Sideband Nulls and Modulation Indexes	H-5

Instrument Overview

This chapter introduces the front- and rear-panel keys and connectors on the HP 8560A, HP 8561B, and HP 8563A Spectrum Analyzers. Complete descriptions of each front-panel function appear in Chapter 2.

The Front Panel

The following paragraphs briefly describe the groups of front-panel keys shown in Figure 1-1.

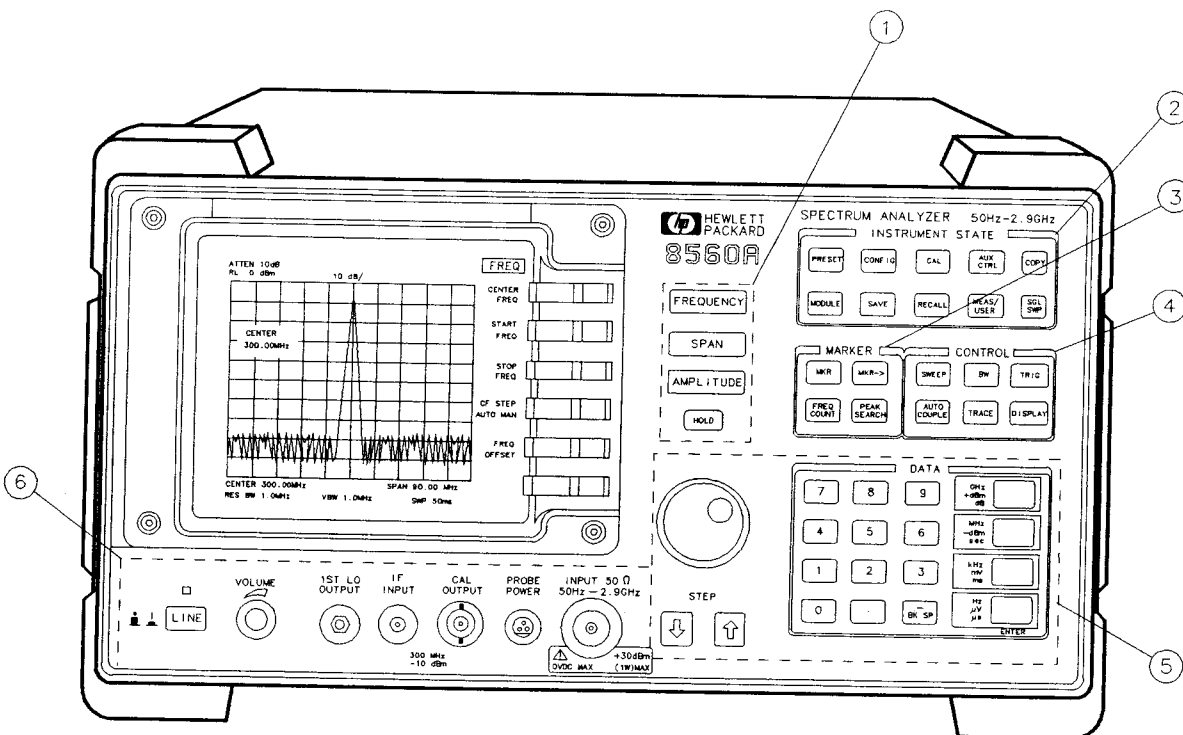

Figure 1-1. HP 8560A Front Panel

1. FREQUENCY, SPAN, and AMPLITUDE are the fundamental functions for most measurements. The HOLD key freezes the active function and holds it at a set value until a function key is pressed again. HOLD also blanks the softkey menu and expands the graticule display horizontally to fill the full CRT.
2. INSTRUMENT STATE functions generally affect the state of the entire spectrum analyzer, not just the state of a single function.

3. **MARKER** functions read out frequencies and amplitudes along the spectrum analyzer trace; allow you to make relative measurements; automatically locate the signal of highest amplitude on a trace; and tune the analyzer to track a signal automatically.
4. **CONTROL** functions allow you to adjust the resolution and video bandwidths, the sweep time, and the display, and to vary other functions that control spectrum analyzer measurement capabilities.
5. **DATA** keys, **STEP** keys, and the knob allow you to change the numeric value of an active function. Use the data keys to enter an exact value or to move quickly from one end of the frequency range to the other. The step keys vary a value in predefined increments or, for some functions, in increments that you choose. The knob allows you to fine-tune most numeric values.
6. The front-panel connectors include an RF input, an active-probe power, a 300 MHz calibrator signal, a 310.7 MHz IF input, and a first LO output. A short specification summary of these connectors is outlined in Table 1-1 below. The IF input is not available with an HP 8560A Option 002. A volume knob is provided for making adjustments to the volume of the built-in speaker. The **LINE** button turns the spectrum analyzer on and off. The LED above the **LINE** button indicates whether or not ac power is applied to the spectrum analyzer.

Caution

The maximum input level to the INPUT 50 Ω is +30 dBm with a minimum of 10 dB input attenuation. Both the HP 8560A and HP 8561B are ac/dc coupled. When ac coupled, the maximum dc voltage to the RF input is 50 V. When dc coupled, the maximum dc voltage is 0 V. Default power-up mode is ac coupled. It is best to leave the analyzer in ac-coupled mode for maximum protection. Exceeding the maximum safe input levels can damage the input attenuator and the input mixer.

Table 1-1. Front-Panel Connector Data

Connector	Frequency Range	Amplitude/ Voltage Limits	
INPUT 50Ω	HP 8560A: 50 Hz—2.9 GHz (dc coupled) 100 kHz—2.9 GHz (ac coupled)	+30 dBm Max 0 V dc Max (dc coupled) 50 V dc Max (ac coupled)	
	HP 8561B: 50 Hz—6.5 GHz (dc coupled) 100 kHz—6.5 GHz (ac coupled)	+30 dBm Max 0 V dc Max (dc coupled) 50 V dc Max (ac coupled)	
	HP 8563A: 9 kHz—22 GHz (dc coupled)	+30 dBm Max 0 V dc Max (dc coupled)	
	9 kHz—26 GHz (dc coupled) (serial prefix 3124A and above)	+30 dBm Max 0 V dc Max (dc coupled)	
	PROBE POWER	—	+15 V, -12.6 V (150 mA max)
	CAL OUTPUT	300 MHz	-10 dBm
	IF INPUT* (for use with external mixers)	310.7 MHz	0 V dc Max
1ST LO OUTPUT	3.00 GHz—6.81 GHz	+16.5 dBm ±2.0 dB +14.5 dBm ± 3.0 dB‡	
RF OUT 50Ω† (tracking generator output)	300 kHz—2.9 GHz	-10 dBm to +1 dBm	
* Not available with an HP 8560A Option 002. † Available only with an HP 8560A Option 002. ‡ LO output of an HP 8560A Option 002.			

Display Annotation

Figure 1-2 illustrates the display annotation.

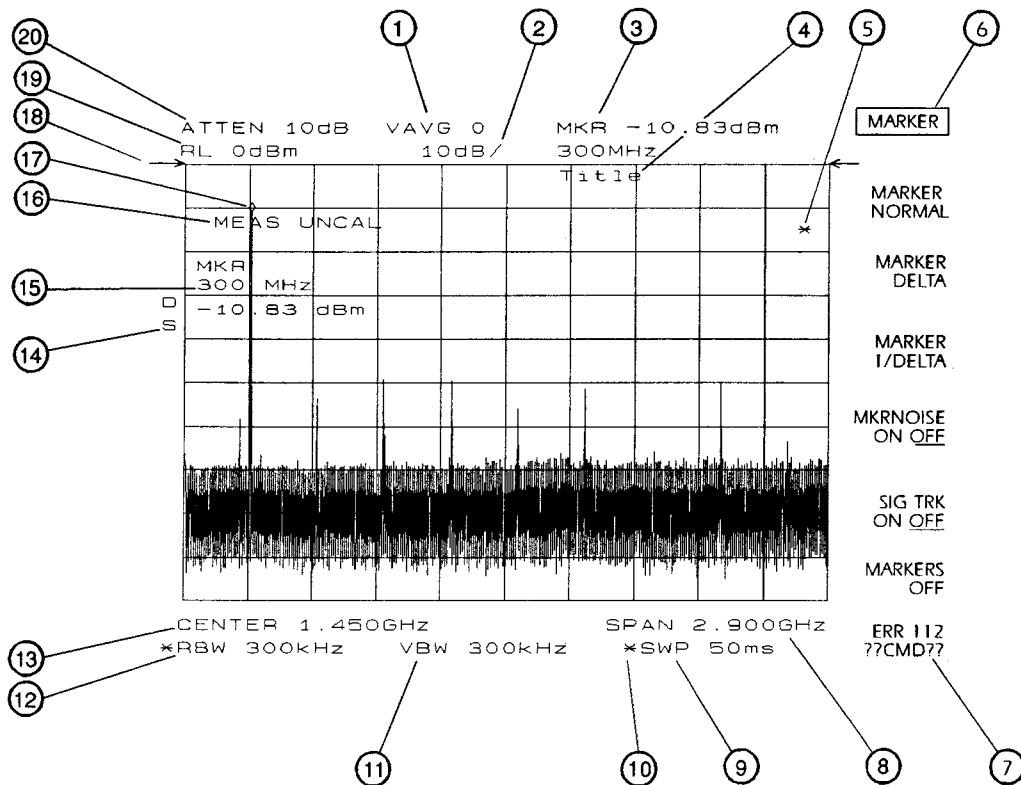

Figure 1-2. Display Annotation

1. Number of video averages.
2. Logarithmic or linear amplitude scale per division.
3. Marker amplitude and frequency.
4. Title area.
5. Data invalid indicator, displayed when analyzer settings are changed before completion of a full sweep.
6. Menu title and softkey menu.
7. Error message area.
8. Frequency span or stop frequency.
9. Sweep time.
10. Indicator of uncoupled function for sweep time, resolution bandwidth, video bandwidth, or input attenuation.
11. Video bandwidth.
12. Resolution bandwidth.
13. Center or start frequency.

14. Active special functions: the following characters appear in a vertical line alongside the graticule. This information is also available by pressing **ANNOT HELP** under the **DISPLAY** key.

A = IF adjust turned OFF
C = DC coupling selected (ac coupling is default)
D = Detector mode set to sample, negative peak, or positive peak
E = Special sweep-time equations in use (refer to tracking generator menus)
F = Frequency offset is less than or greater than 0 Hz
G = Internal tracking generator is ON
K = Signal track is ON
M = Trace math is ON
N = Normalization is ON
R = Reference level offset is less than or greater than 0 dB
S = Single-sweep mode
T = Trigger mode set to line, video, or external
X = 10 MHz reference is external
+ = External mixer bias is greater than 0 mA
- = External mixer bias is less than 0 mA

15. Active function area
16. Message area
17. Marker indicator
18. Indicator of reference-level position when in normalized mode
19. Reference level
20. Input attenuator value (internal mixing) or conversion loss (external mixing)

The Rear Panel

The following paragraphs describe the functions available from the rear panel, as shown in Figure 1-3.

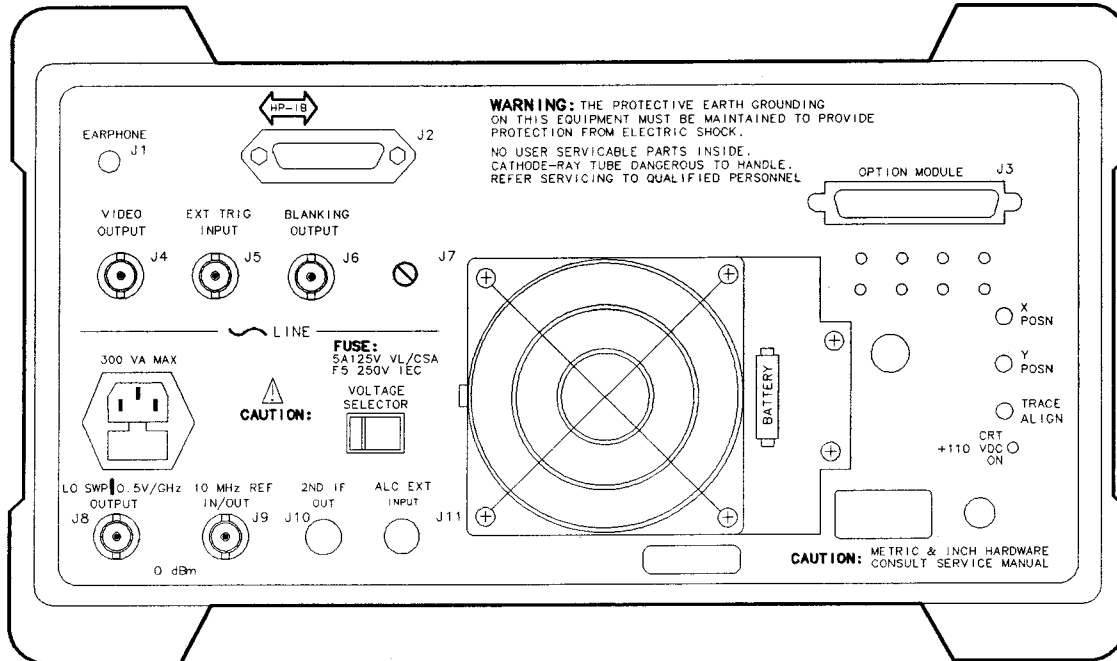

Figure 1-3. HP 8560A Rear Panel

Caution



To prevent damage to the instrument, be sure to set the voltage selector to the appropriate value for your local line-voltage output. For more information, refer to the Installation and Verification Manual.

The LINE input operates at nominally 115 V (47—440 Hz) or at nominally 230 V (47—66 Hz).

J1 provides a 4 Ω impedance earphone jack.

J2 is the Hewlett-Packard Interface Bus (HP-IB) connector.

J3 allows connection of option modules, such as the HP 85629B Test and Adjustment Module or the HP 85620A Mass Memory Module.

J4 provides a detected video signal that is proportional to the vertical deflection of the CRT trace. The output range is 0—1 V when terminated in 50 Ω , and can be used when the display is in 10 dB/div or LINEAR mode. For resolution bandwidth settings less than 300 Hz, a 4.8 kHz IF signal with a dc offset is present at J4.

J5 provides an external trigger input. The input signal range is 0—5 V (TTL). When the trigger is in external mode, the instrument sweep triggers on the rising, positive edge of the signal (about +1.5 V).

J6 provides a blanking output from 0–5 V (TTL) that is low (0 V) during spectrum analyzer sweeps. The output is high (5 V) during retrace and when the instrument is between bands in multiband sweeps. Use this output for pen lift when plotting with nondigital plotters. This output is also useful for synchronizing instruments.

J8 provides two different selectable outputs: a 0–10 V ramp corresponding to the sweep ramp that tunes the local oscillator, or a sweeping dc output of 0.5 V/GHz. The sweeping dc output ranges from 0–2.9 GHz for an HP 8560A, 0–6.5 GHz for an HP 8561B, and 0–22 GHz for an HP 8563A. The output can be selected from the softkeys **0 -> 10V LO SWP** and **.5 V/GHz (FAV)**, respectively, which are in the **REAR PANEL** softkey menu under the **AUX CTRL** key. When using preselected external mixers, the 0.5 V/GHz output provides a signal of approximately 1.5 V/GHz of LO frequency to control the preselected mixer. External tracking generators, such as the HP 85640A, require the 0.5 V/GHz output for operation.

J9 provides a 10 MHz, 0 dBm minimum, time-base reference signal. This connector can be switched to an input, in order to connect an external reference. An external reference must be 10 MHz at a minimum of 0 dBm. To select the external reference mode, use the softkey **10 MHZ EXT INT** in the **REAR PANEL** softkey menu under the **AUX CTRL** key.

J10 is the output for an HP 8560A Option 001, HP 8561B Option 001, or HP 8563A, 310.7 MHz IF output.

J11 is an external leveling input for use with an HP 8560A Option 002 (built-in tracking generator).

X POSN, Y POSN, and TRACE ALIGN allow you to align the spectrum analyzer CRT using a special CRT pattern. Refer to the softkey **CRT ADJ PATTERN** under the **CAL** menu, or consult the Installation and Verification Manual.

Introducing Menus and Softkeys

Pressing a front-panel key allows access to menus of softkeys that appear along the right-hand side of the display screen. These softkeys provide additional functions, depending on the front-panel key selected. The single, dedicated front-panel keys can be used for simple measurements, along with menus of additional functions for more complex measurements.

Softkeys are designated by shading on the key label, for example **FULL SPAN**; front-panel keys are designated by a box around the key label, for example **SPAN**. The softkeys that are displayed depend on which front-panel key is pressed, which menu level is enabled, and whether the softkeys are applicable to the currently-defined measurement parameters. For example, press **FREQUENCY**. This calls up the menu of related frequency functions shown in Figure 1-4. Note on the menu the function labeled **CENTER FREQ**. **CENTER** also appears in the active function block, indicating that it is the active frequency function and can now be changed using any of the data entry controls.

For some softkey functions, data values are required. These may be entered using one of the following three methods: the data keys, the step keys, and the RPG (rotary pulse generator) knob. If applicable, the use of each method is described in the softkey description.

Note



When entering some data values, such as unitless entries, the **ENTER** key must be used to terminate the data entry.

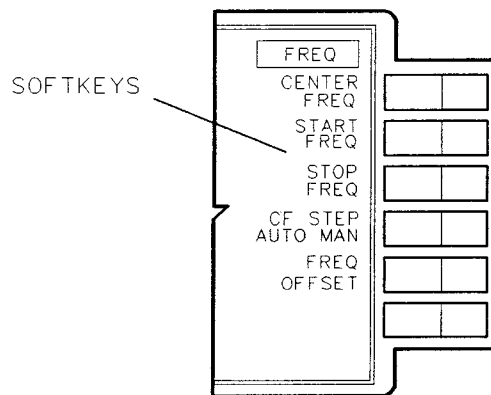

Figure 1-4. Softkey Menu

To activate a different frequency function—for example, the start frequency—press the key to the right of the **START FREQ** annotation. **START** now appears in the active function block, indicating its currently active status. At the bottom of some menus, a **MORE** softkey allows access to additional, related softkeys; the number of pages are also indicated on this softkey. At the top of the menu, a menu title names the front-panel key pressed to obtain the current menu. To activate other frequency functions, press the appropriate softkeys. To select a different softkey menu, press another front-panel key.

When using softkey functions that can either be turned on and off or auto-coupled and manually controlled, the underline indicates which part of the function is enabled. For example, the **ATTEN AUTO MAN** function is auto-coupled when **AUTO** is underlined.

For a complete listing of all the front-panel keys and their softkeys, refer to softkey menu Tables 2-4 through 2-7 at the end of this chapter.

To become more familiar with softkeys, review the following basic measurement example.

Making a Basic Measurement

A basic measurement involves tuning the spectrum analyzer to place a signal on the screen then measuring the frequency and amplitude of the signal with a marker.

We can measure an input signal in four simple steps.

1. Set the center **frequency**.
2. Set the frequency **span**.
3. Activate the **marker**.
4. Set the **amplitude**.

As an example, we will measure the 300 MHz calibration signal. First, switch on the spectrum analyzer (for maximum accuracy, if the analyzer has just been powered up, allow for a 5-minute warm-up). Next, connect the analyzer's CAL OUTPUT to the INPUT 50Ω on the front panel and complete the four steps as described below.

1. Set the center frequency.

Press **FREQUENCY**. This activates the center frequency function, indicated by **CENTER** appearing in the active function block on the left side of the display (see Figure 1-5). To set the center frequency to 300 MHz, use the keys in the DATA section of the front panel and enter 300 MHz. These data keys allow you to select the exact numeric value of the active function, which, in this case, is the center frequency. The step keys and knob also allow you to select function values.

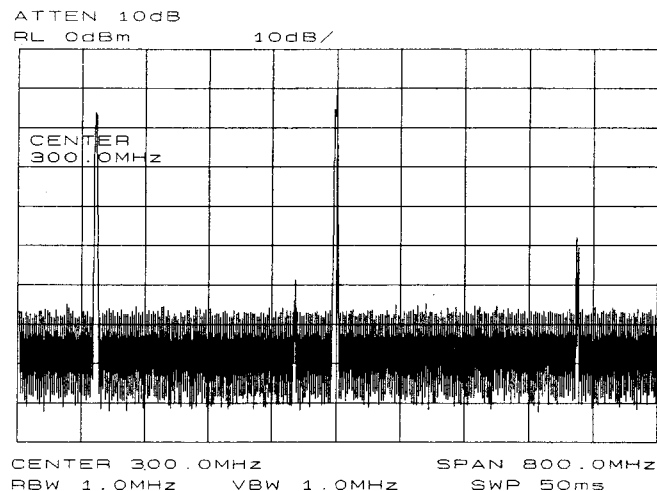

Figure 1-5. 300 MHz Center Frequency

2. Set the frequency span.

Press **SPAN**. Note that **SPAN** is now displayed in the active function block, identifying it as the current active function. To reduce the frequency span—for example, to 20 MHz—either key in 20 MHz or use the **▼** key to “step down” to this value. (Like data keys, step keys can also be used to change the numeric value of the active function.) The resulting display is shown in Figure 1-6. Note that the resolution and video bandwidths are coupled to the

frequency span; they are automatically adjusted to appropriate values for a given span. Sweep-time is also a coupled function.

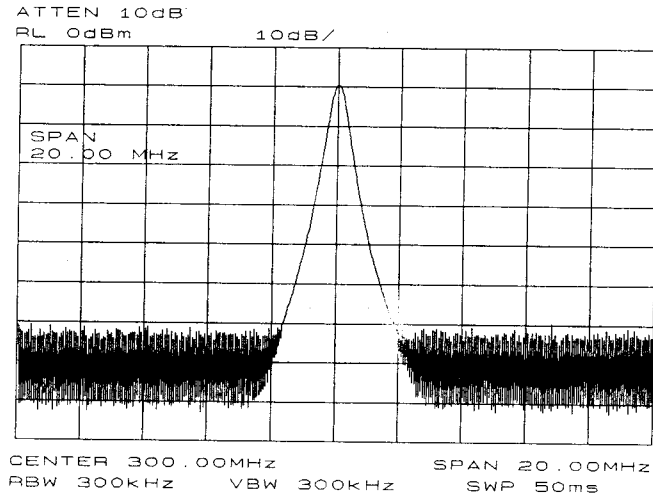

Figure 1-6. 20 MHz Frequency Span

3. Activate the marker.

Press **MKR**, which is located in the MARKER section of the front panel. This activates the normal marker and places it at the center of the trace (in this case, at or near the peak of the signal). The marker reads both the frequency and the amplitude, and displays these values in the active function block. In this case, the marker reads 300.00 MHz and -10.00 dBm, as shown in Figure 1-7.

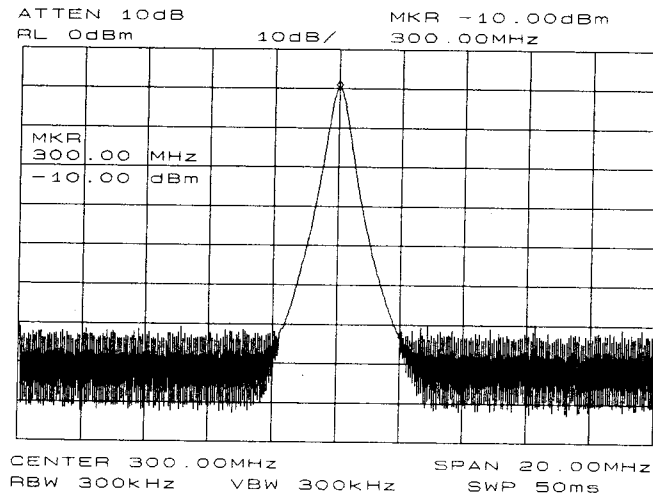

Figure 1-7. Activated Normal Marker

4. Set the amplitude.

Generally, placing the signal peak at the reference level provides the best measurement accuracy. To adjust the signal peak to the reference level (Figure 1-8), press **AMPLITUDE**, then key in -10 dBm, or use either the step keys or the knob. Using the knob is the easiest way to fine-tune the signal peak to the reference level, which is located at the top of the graticule. Since the marker is active, a faster method to fine-tune the signal peak to the reference level is to use **MARKER -> REF LVL**, which is located under the **MKR ->** key. This function sets the reference level equal to the marker amplitude value.

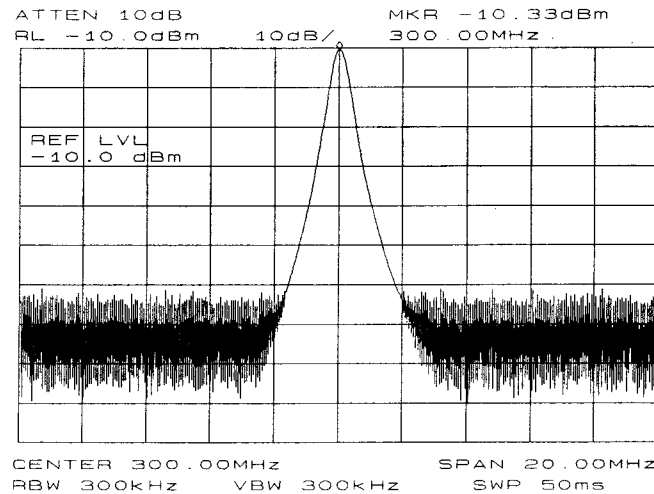

Figure 1-8. -10 dBm Reference Level

Reference-Level Calibration

The reference-level calibration function **REF LVL ADJ** allows the analyzer's internal gain to be adjusted so that when the calibrator signal is connected to the input, a reference level equal to the calibrator amplitude displays the signal at top-screen. The procedure below uses the previous basic measurement to calibrate the instrument.

Turn the markers off by pressing **MKR**, then **MARKERS OFF**. Press **CAL**. This accesses a menu of calibration routines. The fifth function on this new list, labeled **REF LVL ADJ**, allows you to calibrate the amplitude of the instrument. Press **REF LVL ADJ** to activate the function. To calibrate the spectrum analyzer, use the knob on the front panel and adjust the peak of the signal to the reference level, as shown in Figure 1-9. Note the number that appears in the active function block. In this example, the number 5 appears when the signal is adjusted. This number, which ranges from -33 to $+33$, is a relative value indicating how much amplitude correction was required to calibrate the spectrum analyzer. The number is usually around 0. If the amplitude is at either end of the range, or if it cannot be adjusted to a value within this range, consult the Installation and Verification Manual. To store the value, press the **STORE REF LVL** softkey. When entering or storing a value using the data keys, the entry must be terminated with the **ENTER** key, located in the lower right-hand corner of the analyzer.

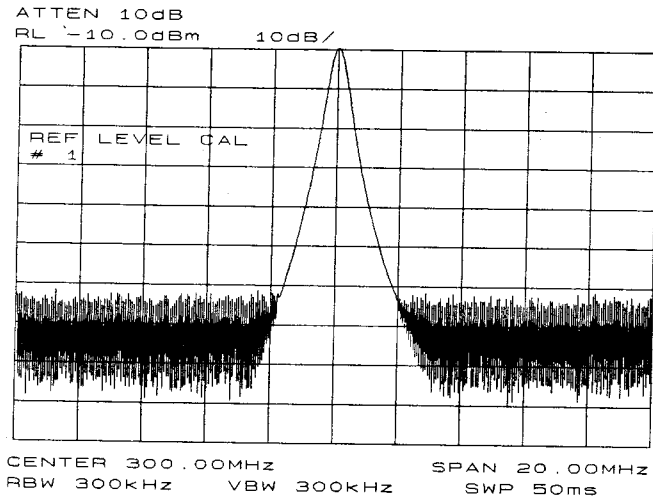

Figure 1-9. Peaked Signal to Reference Level

Recalibrating the reference level is usually necessary only when the ambient temperature changes more than 10 degrees Celsius. Because the spectrum analyzer continually monitor and reduce any IF errors, executing the reference-level calibration is seldom necessary.

Menu Trees

The following is an alphabetical listing, by front-panel key, of all available softkeys.

AMPLITUDE

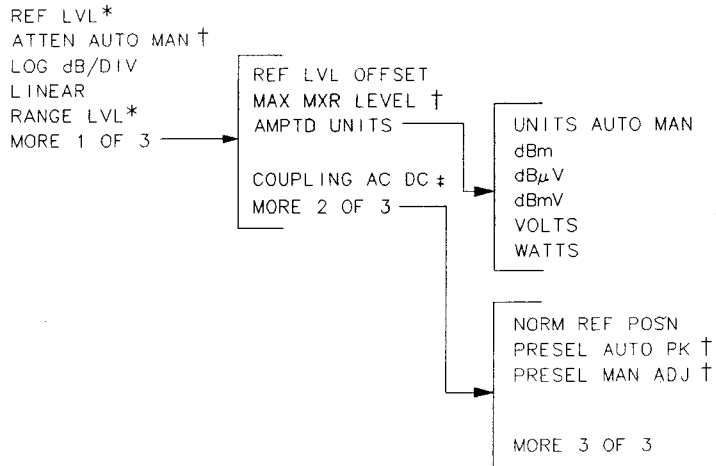

- * Becomes NORM REF LVL when NORMLIZE ON OFF is set to ON.
- † Only available with internal mixing.
- ‡ Not available with an HP 8563A.

AUTO COUPLE

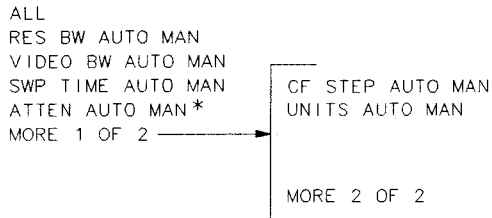

- * Only available with internal mixing.

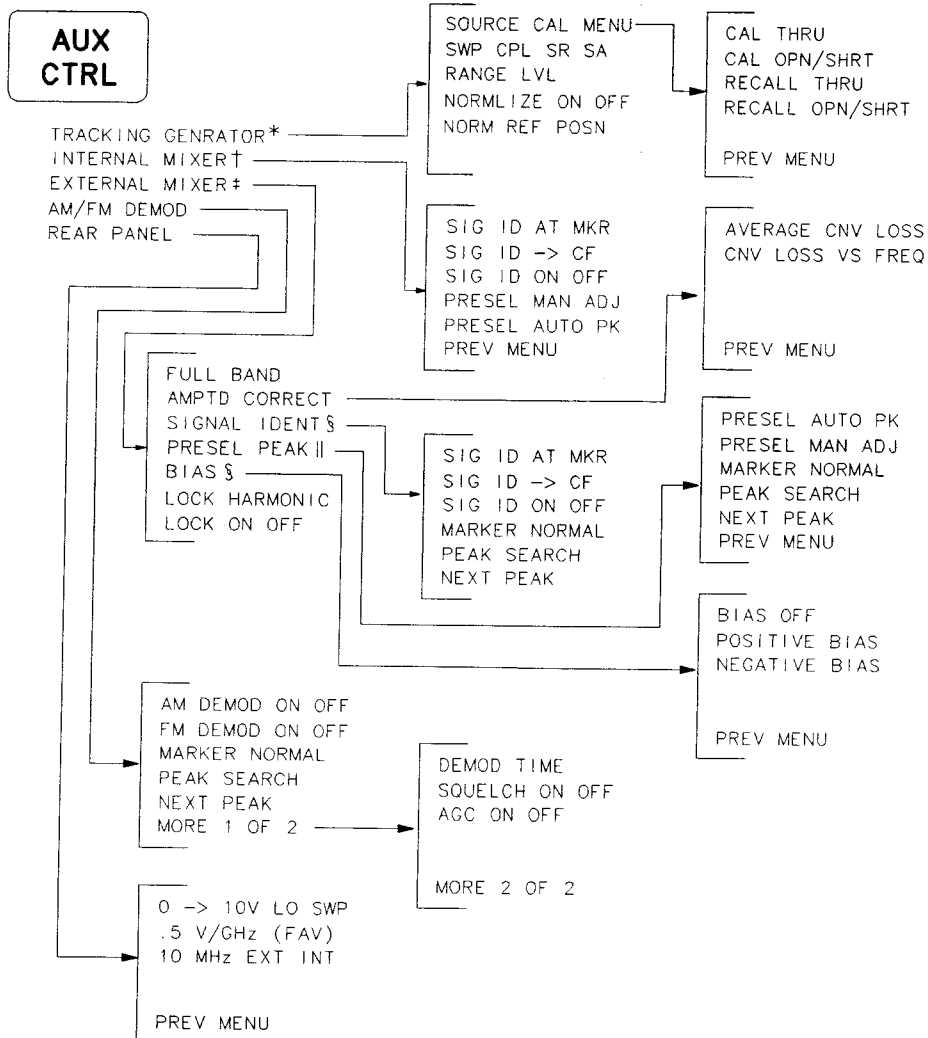

* For use with an external tracking generator only. See next page for built-in tracking generator (HP 8560A Option 002) softkey menu.

† The INTERNAL MIXER softkey and its lower-level softkeys are not available with an HP 8560A Option 002. However, only the INTERNAL MIXER softkey is available with an HP 8560A, its softkey menus are not.

‡ Not available with an HP 8560A Option 002.

§ Available only with unpreselected external mixing.

|| Available only with preselected external mixing.

**AUX
CTRL**

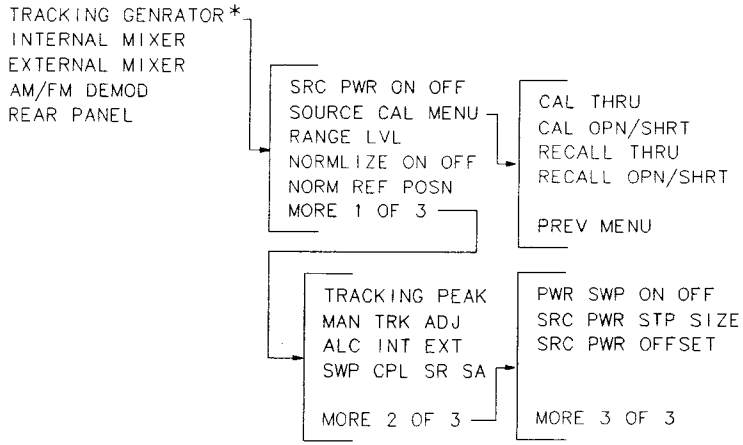

* HP 8560A Option 002 softkey menu.

BW

- RES BW AUTO MAN
- VIDEO BW AUTO MAN
- VBW/RBW RATIO
- RBW/SPAN RATIO
- VID AVG ON OFF

CAL

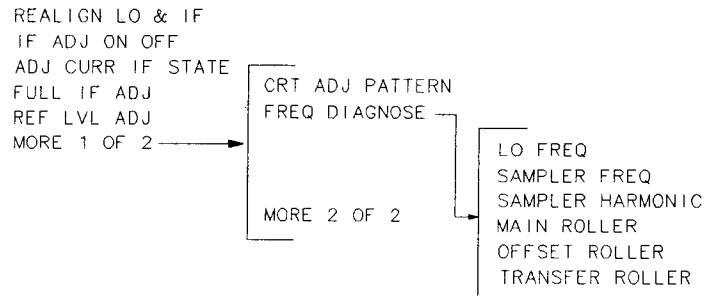

CONF IG

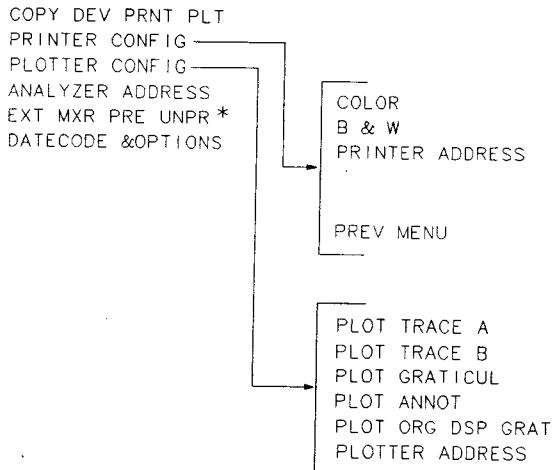

* Not available with an HP 8560A Option 002.

COPY

DISPLAY

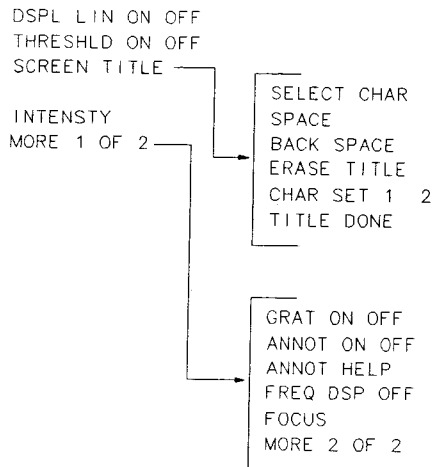

FREQUENCY

CENTER FREQ
START FREQ
STOP FREQ
CF STEP AUTO MAN
FREQ OFFSET

**FREQ
COUNT**

COUNTER ON OFF
COUNTER RES
MARKER NORMAL
MARKER DELTA
PEAK SEARCH
NEXT PEAK

HOLD

**MEAS/
USER**

FFT MEAS
POWER BANDWIDTH
MKBW-3
MKBW-6

MKR

MARKER NORMAL
MARKER DELTA
MARKER 1/DELTA
MKRNOISE ON OFF
SIG TRK ON OFF
MARKERS OFF

MKR->

**Normal Marker
Span > 0 Hz**

MARKER -> CF
MARKER -> REF LVL
MARKER -> CF STEP

**Normal Marker
Zero Span**

MARKER -> REF LVL

**Delta Marker
Span > 0 Hz**

MKR Δ -> CF
MKR Δ -> CF STEP
MKR Δ -> SPAN

**Delta Marker
Zero Span**

MKR $1/\Delta$ -> CF
MKR $1/\Delta$ -> CF STEP

MODULE

PEAK SEARCH

MARKER -> CF *
MARKER DELTA
NEXT PEAK
NEXT PK RIGHT
NEXT PK LEFT
MORE 1 OF 2

PEAK EXCURSN
PEAK THRESHLD

MORE 2 OF 2

* In zero span, this softkey becomes
MARKER NORMAL.

PRESET

LAST STATE

RECALL

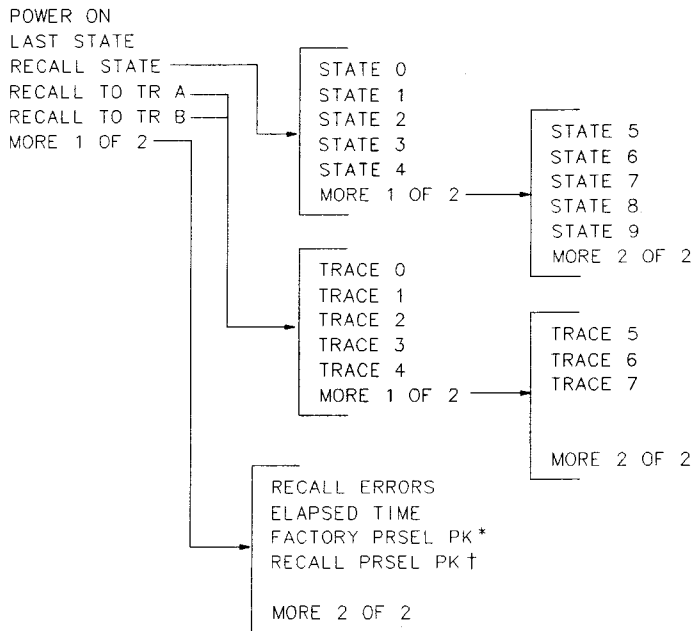

- * Available only with internal mixing.
- † Available only with preselected external mixing and HP 8561B and HP 8563A internal mixing.

SAVE

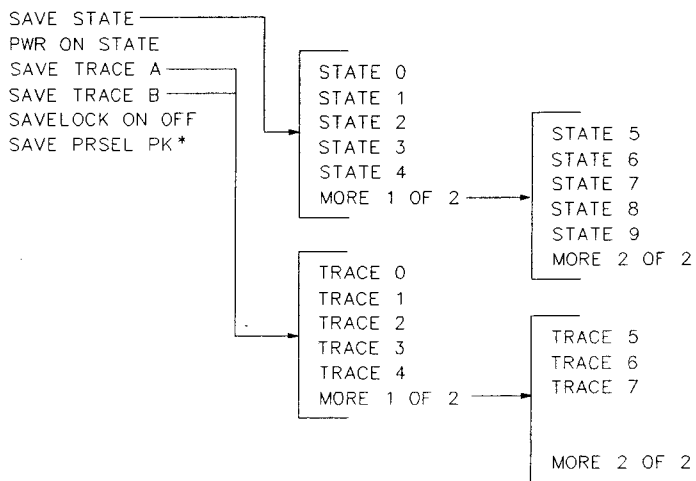

- * Available only with preselected external mixing and HP 8561B and HP 8563A internal mixing.

**SGL
SWP**

SPAN

SPAN
SPAN ZOOM
FULL SPAN
ZERO SPAN
LAST SPAN

SWEEP

SWP TIME AUTO MAN
CONT
SINGLE

TRACE

CLEAR WRITE A
MAX HOLD A
VIEW A
BLANK A
TRACE A B
MORE 1 OF 3

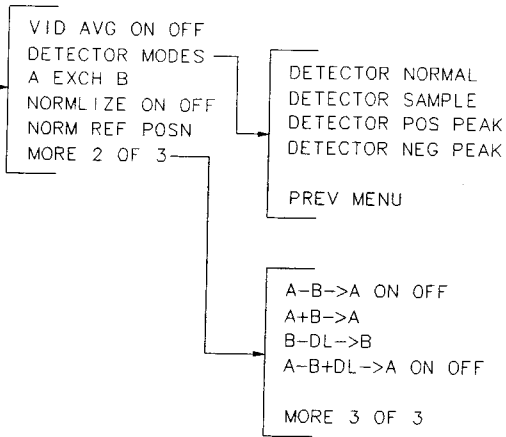

TRIG

CONT
SINGLE
FREE RUN
VIDEO
LINE
EXTERNAL

Function Descriptions

This chapter describes the functions that are available from the front panel of HP 8560A, HP 8561B, and HP 8563A Portable Spectrum Analyzers. Descriptions are organized by the front-panel keys in each of the four groups listed below. For an alphabetical listing of all functions, refer to Appendix B.

Fundamental Functions

FREQUENCY	2-3
SPAN	2-5
AMPLITUDE	2-7
HOLD	2-12

Instrument State Functions

PRESET	2-14
CONFIG	2-15
CAL	2-19
AUX CTRL	2-22
COPY	2-43
MODULE	2-44
SAVE	2-45
RECALL	2-48
MEAS/USER	2-51
SGL SWP	2-61

Marker Functions

MKR	2-63
MKR->	2-65
FREQ COUNT	2-67
PEAK SEARCH	2-69

Control Functions

SWEEP	2-73
BW	2-74
TRIG	2-76
AUTO COUPLE	2-77
TRACE	2-79
DISPLAY	2-83

Fundamental Functions

This section describes the functions available from **FREQUENCY**, **SPAN**, **AMPLITUDE**, and **HOLD**.

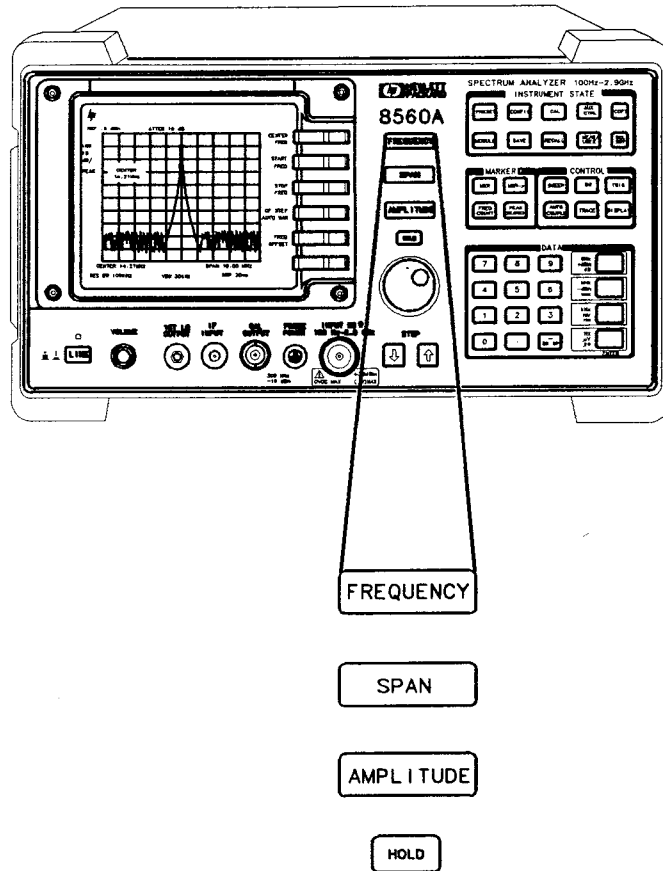

Frequency

FREQUENCY

CENTER FREQ
START FREQ
STOP FREQ
CF STEP AUTO MAN
FREQ OFFSET

FREQUENCY accesses a menu of frequency-related functions, which are described below. **FREQUENCY** also activates the center frequency function when the spectrum analyzer is in the center-frequency/span mode. If the analyzer is in start-frequency/stop-frequency mode, the start frequency is activated.

CENTER FREQ Activates the center frequency and sets the spectrum analyzer to the center-frequency/span mode. **CENTER FREQ** can be adjusted using the data keys, the step keys, or the knob. If a selected center frequency is not compatible with the current span, the span is adjusted to the nearest value that will accommodate the desired frequency.

START FREQ Activates the start frequency and sets the spectrum analyzer to the start-frequency/stop-frequency mode. **START FREQ** can be adjusted using the data keys, the step keys, or the knob. When adjusting **START FREQ**, if the selected start frequency exceeds the stop frequency, the stop frequency increases to equal the start frequency plus the minimum swept span (100 Hz).

STOP FREQ Activates the stop frequency and sets the spectrum analyzer to the start-frequency/stop-frequency mode. **STOP FREQ** can be adjusted using the data keys, the step keys, or the knob. When adjusting **STOP FREQ**, if the selected stop frequency is less than the start frequency, the start frequency decreases to equal the stop frequency minus the minimum swept span (100 Hz).

CF STEP AUTO MAN Adjusts the center-frequency step-size. When this function is in coupled (AUTO) mode and center frequency is the active function, pressing a step key yields a one-division shift (10 percent of span) in the center frequency for spans greater than 0 Hz. For zero span, pressing a step key when center frequency is the active function yields a center-frequency shift equal to 25 percent of the resolution bandwidth. For manual (MAN) mode, the step size can be adjusted using the data keys, the step keys, or the knob. After entering a step size and changing the active function to **CENTER FREQ**, use the step keys to adjust the center frequency by the step size selected. This function is useful for quickly tuning to the harmonics of an input signal. For example, to tune to the harmonics of a 300 MHz signal, set **CF STEP AUTO MAN** to MAN and enter 300 MHz. If the center frequency is at 300 MHz, pressing the step key increases the center frequency to 600 MHz, which is equal to the second harmonic. Pressing the STEP key again increases the center frequency by another 300 MHz, to 900 MHz. **CF STEP AUTO MAN** indicates whether the step size is in a coupled (AUTO) or manual (MAN)

mode. When the step size is in manual mode, pressing **CF STEP AUTO MAN** returns the function to coupled mode.

**FREQ
OFFSET**

Adds an offset to the displayed frequency values, including marker frequency values. It does not affect the frequency range of the sweep. Enter the value using the data keys, the step keys, or the knob. When this function is active (that is, when the frequency offset is not equal to 0 Hz), an **F** appears on the left edge of the display.

Span

SPAN

SPAN
SPAN ZOOM
FULL SPAN
ZERO SPAN
LAST SPAN

SPAN accesses the menu of span-related functions, which are described below. **SPAN** also activates the span function and sets the spectrum analyzer to center-frequency/span mode.

Note



When using an HP 8563A, the low band of the spectrum analyzer ranges from 9 kHz to 2.9 GHz. The upper band ranges from 2.75 GHz to 22 GHz (26.5 GHz with an Option 026). The frequency span cannot be set to overlap both bands at the same time, except in single-sweep mode. For example, two sweeps are required to cover the range of 2.0 GHz to 3.5 GHz: a low band sweep from 2.0 GHz to 2.9 GHz, and an upper band sweep from 2.9 GHz to 3.5 GHz.

SPAN

Activates the span-width function and sets the spectrum analyzer to center-frequency/span mode. **SPAN** can be changed using the data keys, the step keys, or the knob. The span can be set to 0 Hz using either the data keys or **ZERO SPAN**.

SPAN ZOOM

Tracks a marked signal and activates the span function. If no marker is active, an active marker is positioned at the highest peak, signal track is turned on, and SPAN is made the active function. Once the span is entered and the new span is reached, the marker and signal track both remain on with SPAN as the active function. Therefore, keying in consecutive frequency span values continue to activate the span-zoom algorithm. To deactivate the span-zoom algorithm, press **(MKR)**, and then press **MARKERS OFF**, or set **SIG TRK ON OFF** to OFF.

FULL SPAN

Sets the spectrum analyzer to the center-frequency/span mode and sets the span to the maximum range. Full span for the HP 8560A is 2.9 GHz, 6.5 GHz for the HP 8561B, and for the HP 8563A, 2.9 GHz for low band and 19.75 GHz for high band (23.75 GHz for Option 026).

For the HP 8563A, the maximum span selected depends on whether the center frequency is in low band or high band. If the center frequency is in low band, then maximum span is from 0 Hz to 2.9 GHz. If the center frequency is in high band, then the maximum range is 2.75 GHz to 22 GHz (2.75 GHz to 26.5 GHz for Option 026).

**ZERO
SPAN**

Sets the span to 0 Hz. This effectively allows an amplitude versus time mode in which to view signals. This is especially useful for viewing modulation.

Note



Zero span is used with resolution bandwidths greater than 100 Hz. If zero span is activated when using a 10, 30, or 100 Hz resolution bandwidth, the message INCREASE BW TO > 100 Hz appears on-screen.

**LAST
SPAN**

Sets the spectrum analyzer to the previously selected span, allowing you to toggle between two settings. For example, you can toggle between zero span and a larger span to view modulation in both the frequency and time domains.

Amplitude

AMPLITUDE

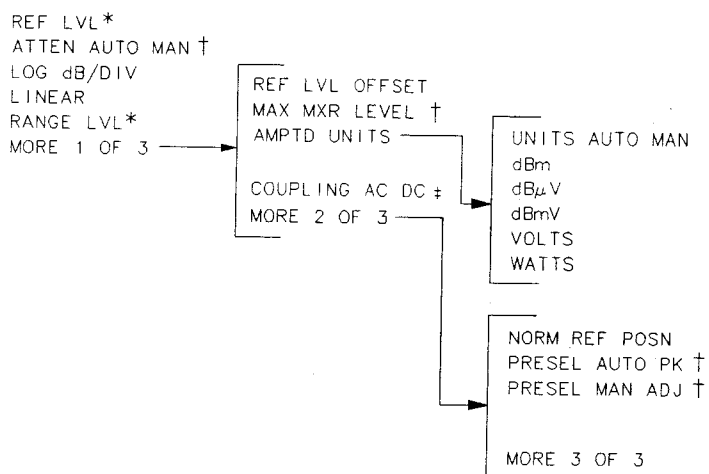

* Becomes NORM REF LVL when NORMLIZE ON OFF is set to ON.

† Only available with internal mixing.

‡ Not available with an HP 8563A.

AMPLITUDE accesses a menu of amplitude-related functions, which are described below.

AMPLITUDE also activates the reference-level function.

REF LVL Activates the reference-level function. The reference level can be adjusted using the data keys, the step keys, or the knob. The reference level is the top line of the graticule. For best measurement accuracy, place the peak of the signal of interest on the reference-level line. The spectrum analyzer input attenuator is coupled to the reference level and is automatically adjusted to avoid compression of the input signal. The function **MAX MXR LEVEL**, which is described below, is closely related to the reference level.

Table 2-1. Frequency Bands and Their Minimum Reference Levels

Band	Minimum Reference Level 0 dB attenuation	
	Log Scale	Linear Scale
50 Hz to 2.9 GHz (all analyzers)	-120.0 dBm	2.2 μ V (-100 dBm)
HP 8561B only: 2.75 GHz to 6.5 GHz	-120.0 dBm	2.2 μ V (-100 dBm)
HP 8563A only: 2.75 GHz to 6.46 GHz	-120.0 dBm	2.2 μ V (-100 dBm)
5.8 GHz to 13 GHz	-115.0 dBm	4.0 μ V (-95 dBm)
12.4 GHz to 19.7 GHz	-105.0 dBm	12.6 μ V (-85 dBm)
19.1 GHz to 22 GHz	-100.0 dBm	22.4 μ V (-80 dBm)

**NORM REF
LVL**

*Available only when **NORMLIZE ON OFF** is ON replacing **REF LVL**.*

Activates the normalized reference level. Adjustments may be made using the data keys, step keys, or knob. The units for the normalized reference level is dB. **NORM REF LVL** is *not* equivalent to **REF LVL**. When **NORM REF LVL** is adjusted, the input attenuator and IF step gains are not affected. This function is a trace-offset function, enabling the user to offset the displayed trace without introducing errors into the stimulus-response measurement.

**ATTEN
AUTO MAN**

Available with internal mixing only.

Adjusts the spectrum analyzer input attenuator. In AUTO mode, the input attenuator is coupled to the reference level. In manual (MAN) mode, the input attenuation can be adjusted using the data keys, the step keys, or the knob. The attenuator ranges from 0 dB to 70 dB in 10 dB increments; 0 dB attenuation can only be selected using the data keys.

Attenuation is normally a coupled function and is automatically adjusted when the reference level changes. The reference level, however, generally does not change when the attenuation changes. The attenuator is adjusted so that the maximum signal amplitude at the input mixer is -10 dBm or less. For example, if the reference level is +23 dBm, the attenuation is 40 dB for an input of -17 dBm at the mixer ($23 - 40 = -17$). This prevents signal compression. Set **ATTEN AUTO MAN** to MAN to adjust the input attenuator. A line under AUTO or MAN indicates whether the attenuator is coupled (AUTO) or in manual mode (MAN). When the input attenuator is in manual mode, pressing **ATTEN AUTO MAN** again recouples the attenuator to the reference level.

Caution



Maximum input signal amplitude is +30 dBm with at least 10 dB of input attenuation. Higher amplitude signals can result in damage to the input attenuator or to the input mixer.

**LOG
dB/DIV**

Selects a 1, 2, 5, or 10 dB logarithmic amplitude scale. The default value is 10 dB/division. 1 dB/division and 5 dB/division scales are not available in fast zero span (sweep times less than 30 ms). Any activated markers read out in dBm, and delta markers read the difference between the markers in dB. If desired, it is possible to select other units while in a log-scale mode (see **UNITS**, below).

LINEAR

Selects a linear amplitude scale. Measurements using a linear scale are normally read in millivolts, but other units can be selected (see **UNITS**, below).

**RANGE
LVL**

*Appears only when **NORMLIZE ON OFF** is set to ON.*

Activates the dynamic-range-level function, which corresponds to the top of the display in dBm. **RANGE LVL** ensures that the displayed range is compression-free by adjusting the input attenuator and IF gain accordingly. **RANGE LVL** is equivalent to **REF LVL**, which is commonly used in signal-analysis measurements.

When in normalized mode **NORM REF LVL** and **NORM REF POSN** affect the value of the top of the display (that is, the top of screen does not necessarily

represent the gain compression limit). If the actual measured signal is beyond the gain compression limit, or below the bottom line of the graticule, the error message ERR 903 A > DLMT will appear. Adjusting **RANGE LVL** until the error message disappears assures the user that the measured signal level is no longer beyond the measurement limits of the instrument. If the signal of interest is both above the gain compression limit and below the bottom line of the graticule, changing **RANGE LVL** does not clear the error message. Refer to Chapter 3 for a measurement example using **RANGE LVL**.

ERR 904 B > DLMT appears in normalized mode only if any one of the following conditions occur:

- Any data point of the calibration trace is off-screen.
- No calibration has been performed after a preset.
- Trace B is blank.

To ensure valid calibration trace data, readjust analyzer settings, turn normalize off, and perform a **CAL THRU** or **CAL OPN/SHRT** operation.

RANGE LVL can be adjusted from +30 dBm to -120 dBm using the data keys, step keys, or the knob.

Accesses additional softkeys, which are described below.

MORE
1 OF 3

REF LVL
OFFSET

Introduces an offset to all amplitude readouts (for example, reference level and marker amplitude). It does not change the position of the trace on-screen. The offset is in dB, regardless of the selected scale and units. The offset can be useful to account for gains or losses in accessories connected to the input of the analyzer. To enter an offset value use the data keys, the step keys, or the knob. When this function is active, an R appears on the left edge of the display.

MAX MXR
LEVEL

Available with internal mixing only.

Selects the maximum signal amplitude seen at the input mixer. This value is always in dBm, regardless of the selected scale or units. **MAX MIXER LEVEL** is especially useful when distortion-free dynamic range is an important consideration.

The following procedure explains how to check for signal compression quickly. Press **MAX MXR LEVEL** and increase the attenuation using the step key. If the signal peak shifts more than 1 dB, the signal is in compression. In this case, continue to increase the attenuation until the peak moves less than 1 dB between steps; then decrease the attenuation one step.

**AMPTD
UNITS**

Accesses additional amplitude functions, which are described below.

Note

Amplitude units are not available in normalize mode.



**UNITS
AUTO MAN**

Selects amplitude units automatically (AUTO) or manually (MAN). When in AUTO mode, the default units are dBm (in log scale) or **VOLTS** (in linear scale). The following units are available from this menu.

dBm

(absolute decibel above 1 milliwatt)

dB μ V

(absolute decibel above 1 microvolt)

dBmV

(absolute decibel above 1 millivolt)

VOLTS

WATTS

**COUPLING
AC DC**

Not available with an HP 8563A.

Toggles the input between ac and dc coupling. The preset state of the analyzer is ac-coupled. This protects the input of the analyzer from damaging dc signals. It also limits the lower frequency-range response to 100 kHz (although the analyzer will tune down to 0 Hz with signal attenuation).

**MORE
2 OF 3**

Accesses additional softkeys, which are described below.

**NORM REF
POSN**

Allows the user to adjust the normalized reference-position that corresponds to the position on the graticule where the difference between the measured and calibrated traces resides. The dB value of normalized reference-position is equal to the normalized reference level. The normalized reference-position may be adjusted between 0.0 and 10.0 (corresponding to the bottom and top graticule lines, respectively) using the data keys, step keys, or knob.

The normalized-reference-position adjustment allows measured data to be compared to a reference position, where the difference between the measured data and the reference position represents the gain or loss of the device under test.

When normalization is on, two indicators (-> and <-) appear on-screen to mark the location of the normalized reference position.

**PRESEL
AUTO PK**

Available only with internal mixing.

Automatically peaks the preselector on the desired signal on a trace, when the start frequency is set equal to or above 2.9 GHz. Set the trace to clear-write mode, place a marker on the desired point, then press **PRESEL AUTO PEAK**. The peaking routine zooms to zero span, peaks the preselector tracking, then returns to the original span. To read the new preselector peaking number, press **PRESEL MAN ADJ**.

The **PRESEL AUTO PK** softkey appears under three different menus—**AMPLITUDE**, **INTERNAL MIXER**, and **EXTERNAL MIXER**. This **PRESEL AUTO PK** softkey is only available for use with internal mixing. Refer to the **PRESEL AUTO PK** softkey under the **EXTERNAL MIXER** menu of functions for preselected external mixers.

Note

When **PRESET** is pressed, the preselector data stored by the user does not change. However, the factory settings now become active.

Factory preselector data always takes precedence over user-activated preselected data, unless the user data is explicitly recalled using **RECALL PRSEL PK**. For more information on storing and recalling preselector data, refer to the **SAVE PRSEL PK** and **RECALL PRSEL PK** softkeys.

**PRESEL
MAN ADJ**

Available only with internal mixing.

Allows the user to adjust the preselector tracking, when the start frequency is set equal to or above 2.9 GHz. The HP 8561B is preselected from 2.75 GHz to 6.5 GHz, and from 2.75 GHz to 22 GHz for an HP 8563A. Place a marker on the desired signal on a trace, then press **PRESEL MAN ADJ**. The current preselector tracking number, which is displayed in the active function block, can be changed using the data keys, the step keys, or the knob. The value ranges from 0 to 255. If no marker is active, pressing **PRESEL MAN ADJ** automatically activates a marker at the peak. Executing the function affects data in the current data table (which may be data from either the user or the factory data tables). To save this data, use **SAVE PRSEL PK** found under **SAVE**.

The **PRESEL MAN ADJ** softkey appears under three different menus—**AMPLITUDE**, **INTERNAL MIXER**, and **EXTERNAL MIXER**. This **PRESEL MAN ADJ** softkey is only available for use with internal mixing. Refer to the **PRESEL MAN ADJ** softkey under the **EXTERNAL MIXER** menu of functions for preselected external mixers.

**MORE
3 OF 3**

Accesses the first menu of softkeys.

Hold

HOLD

HOLD clears the active function and the current softkey menu from the display, and expands the display horizontally to the full width of the screen. The width of the trace and graticule increase to occupy the resulting blank space.

Instrument State Functions

This section describes the functions available from the INSTRUMENT STATE section of the front panel.

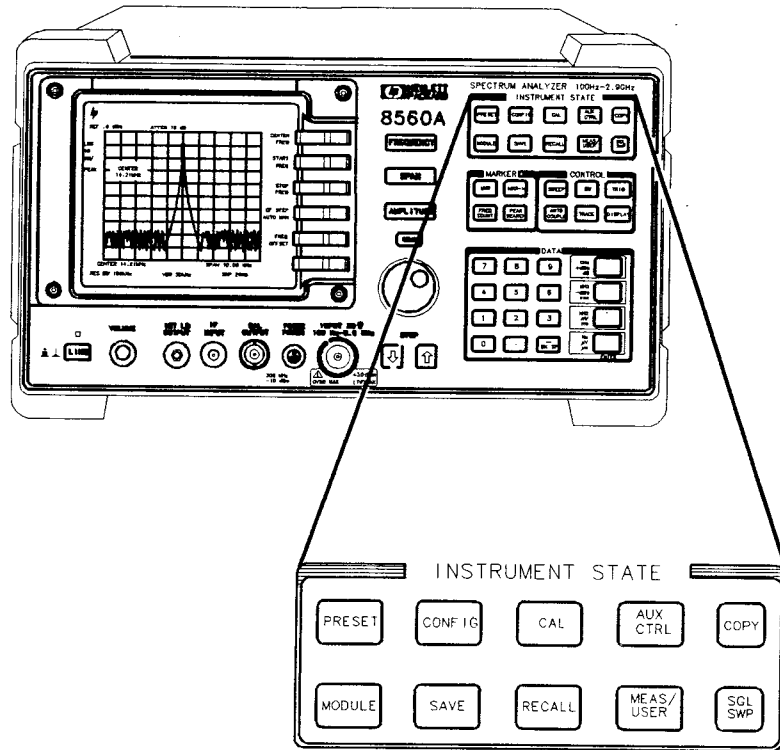

Preset

PRESET

LAST STATE

PRESET sets the spectrum analyzer to a known, predefined state. **PRESET** does not affect the spectrum analyzer HP-IB address, the contents of any data or trace registers, stored preselector data, or any state and trace registers that are locked (SAVELOCK). **PRESET** also accesses the additional softkey function described below. Refer to Appendix A, "Instrument Preset State," for a description of each analyzer's predefined state which is stored in memory and cannot be changed.

Note



When **PRESET** is pressed, the preselector data stored by the user does not change. However, the factory settings now become active.

**LAST
STATE**

Recalls the state that existed before the last front-panel key function was activated. Since the last key activated was **PRESET**, the recalled state will either be the one before **PRESET** was invoked, or the state that the instrument was in when power was turned off.

Configuration

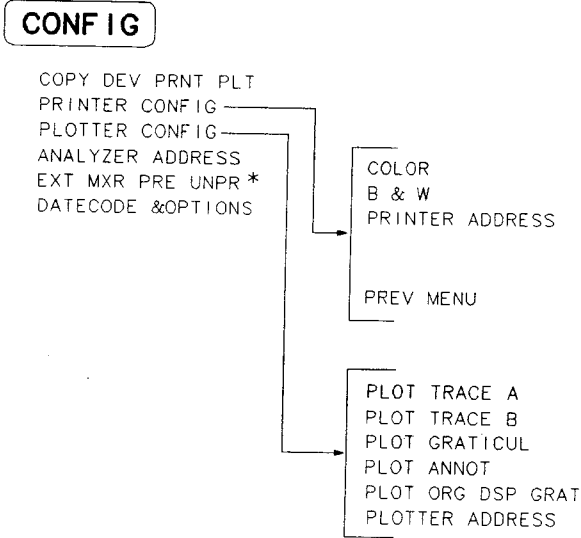

* Not available with an HP 8560A Option 002.

CONFIG accesses a menu of settings that allow the information on the CRT display to be copied to an external HP-IB printer or plotter. Under this menu, the HP-IB address of the analyzer can also be changed using **ANALYZER ADDRESS**.

COPY DEV PRNT PLT Designates the hardcopy device (printer or plotter) used when the **COPY** key is activated. The current copy selection is underlined.

PRINTER CONFIG Accesses printer configuration options, which are described below.

Note  If the printer is not connected when any of the print functions are executed, then the message **CONNECT PRINTER** appears in the active function block.

COLOR Selects the HP PaintJet color printer (or compatible device) for use by the **COPY** key.

B & W Selects operation with a monochrome printer, such as an HP ThinkJet, for use by the **COPY** key.

PRINTER ADDRESS Displays the current HP-IB address of the designated printer. A new address can be entered by using the data keys (and pressing **ENTER**), the step keys, or the knob, and pressing **STORE HP-IB ADR**. The new address is stored in nonvolatile memory and is recalled when the power is cycled. If the printer address is redefined without saving it with

STORE HPIB ADR., the redefined address is valid after **PRESET** is pressed, but not through a power cycle.

**PREV
MENU**

Accesses the previous menu of softkeys.

**PLOTTER
CONFIG**

Accesses plotter configuration options, which are described below.

Note



If the plotter is not connected when any of the plot functions are executed, then the message **CONNECT PLOTTER** appears in the active function block.

**PLOT
TRACE A**

Plots only the contents of trace A and any markers associated with trace A. When **PLOT TRACE A** is active, **STOP TRACE A** appears in its place, allowing you to stop the plot before it is finished. If trace A is blanked, the message **TRACE IS BLANKED** will momentarily appear in the active function area, and no plotting will occur.

**PLOT
TRACE B**

Plots only the contents of trace B and any markers associated with trace B. When **PLOT TRACE B** is active, **STOP TRACE B** appears in its place, allowing you to stop the plot before it is finished. If trace B is blanked, the message **TRACE IS BLANKED** will momentarily appear in the active function area, and no plotting will occur.

**PLOT
GRATICUL**

Plots only the graticule. When **PLOT GRATICUL** is active, **STOP GRATICUL** appears in its place, allowing you to stop the plot before it is finished. If the graticule is turned off, no output will be plotted.

**PLOT
ANNOT**

Plots only the annotation (excluding the menu, trace markers, and error codes). When **PLOT ANNOT** is active, **STOP ANNOT** appears in its place, allowing you to stop the plot before it is finished. If the annotation is turned off, no output will be plotted.

**PLOT ORG
DSP GRAT**

Selects either the display (DSP) or the graticule (GRAT) origin mode. Hewlett-Packard plotters allow the user to define the size of the plot using P1 and P2 parameters. P1 defines the lower left-hand corner of the plot, while P2 defines the upper right-hand corner.

When DSP is selected, the analyzer scales the full CRT display (excluding the softkey area), so that the corresponding hardcopy plot resides completely within the user-defined P1 and P2 limits.

When GRAT is selected, P1 and P2 correspond to the lower-left and upper-right corners of the graticule. If a full plot is activated using **COPY**, the graticule will be scaled according to the P1 and P2 parameters; however, the

annotation will be plotted outside the defined range. GRAT allows you to position the desired plot information on a preprinted graticule to save plotting time.

This softkey function is locked out when any plot is in process or when any plot is pending.

**PLOTTER
ADDRESS**

Displays the current HP-IB address of the plotter. A new address can be entered by using the data keys (and pressing **ENTER**), the step keys, or the knob, and pressing **STORE HPIB ADR**. The new address is stored in nonvolatile memory and is recalled when the power is cycled. If the plotter address is redefined without saving it with **STORE HPIB ADR**, the redefined address is only valid when **PRESET** is pressed, and not through a power cycle. This softkey is not displayed whenever a plot is pending or in progress.

**ANALYZER
ADDRESS**

Displays the current HP-IB address of the spectrum analyzer. A new address can be entered by using the data keys (and pressing **ENTER**), the step keys, or the knob, and pressing **STORE HPIB ADR**. If the analyzer address is redefined without saving it with **STORE HPIB ADR**, the redefined address is only valid when **PRESET** is pressed, and not through a power cycle.

**EXT MXR
PRE UNPR**

Not available with an HP 8560A Option 002.

Selects either preselected external mixing mode or unselected external mixing mode. This softkey sets the external mixer configuration used by the softkey menu found under the **EXTERNAL MIXER** softkey under **AUX CTRL**.

If the preselected external mixer mode is selected, rear-panel output J8 of the analyzer is automatically switched to the 0.5V/GHz (FAV) mode with an output of 1.5 V/GHz of the LO frequency. The 1.5 V/GHz of the LO frequency definition is required for the HP 11974 Series preselected external mixers.

Note



There are two different types of external mixers available, preselected and unselected. The **EXT MXR PRE UNPR** softkey function applies only to the selection of the type of external mixer to be used. It does not switch the analyzer from internal to external mixing.

**DATECODE
&OPTIONS**

Displays the analyzer's firmware datecode, the instrument serial number, the model number, and any options present.

For the HP 8560A, valid options are:

- Option 001 Second IF Output
- Option 002 Built-In Tracking Generator
- Option 003 Precision Frequency Reference

For the HP 8561B, valid options are:

- Option 001 Second IF Output
- Option 003 Precision Frequency Reference

For the HP 8563A, valid options are:

- Option 026 26.5 GHz Frequency Extension
- Option 103 Delete Precision Frequency Reference
- Option 104 Delete HP 85620A

Calibration

CAL

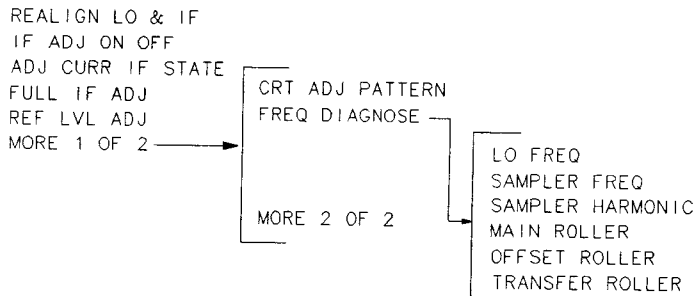

CAL displays all menus related to calibration and diagnostic routines.

REALIGN LO & IF

Activates the automatic local oscillator (LO) and intermediate frequency (IF) alignment routines. These are the same routines that occur when **LINE** is switched on. When **REALIGN LO & IF** is active, **STOP REALIGN** appears and all other softkeys are blank during this time. **STOP REALIGN** allows you to stop the IF adjustment routine before it is finished; however the routine is not stopped immediately. If **STOP REALIGN** is activated, the amplitude accuracy of measurements made by the instrument may not meet published specifications.

IF ADJ ON OFF

Allows you to turn the automatic IF adjustment ON or OFF. This function is normally ON. When **IF ADJ** is ON, various parameters in the IF are adjusted during the retrace time of the sweep. Several minutes and several sweeps may be required to complete a cycle of all the adjustments. This function is automatically deactivated when the analyzer is set to zero span, the sweep time is less than 50 ms, or when the HP 85620A Mass Memory Module or HP 85629B Test and Adjustment Module is used. It is automatically reactivated when the analyzer is set to a span greater than 0 Hz or the sweep time is greater than or equal to 50 ms. When reactivated, several sweeps may need to be taken before automatic adjustment is completed.

When **IF ADJ ON OFF** is off, an A appears in the special functions area at the left-hand side of the display screen.

ADJ CURR IF STATE

Executes a routine that adjusts only the current bandwidth's state. During this adjustment, the message **IF ADJUST STATUS: <text>** appears in the active function area. Depending on which portion of the IF system is being adjusted, either **AMPLITUDE** or a specific resolution bandwidth (for example, 1 MHz) is displayed in the message.

FULL IF ADJ

Executes a complete adjustment of the IF system. Once activated, the softkey changes to **STOP ADJUST** which, if pressed, stops the IF adjustment and returns the analyzer to its previous state. During this adjustment, the message **IF ADJUST STATUS: <text>** appears in the active function area. Depending on which portion of the IF system is being adjusted, either

AMPLITUDE or the specific resolution bandwidth (for example, 300 Hz) is displayed in the message.

REF LVL
ADJ

Allows the analyzer's internal gain to be adjusted so that when the calibrator signal is connected to the input, a reference level equal to the calibrator amplitude displays the signal at top-screen. When REF LVL ADJ is pressed, the STORE REF LVL softkey appears in its place and a unitless number appears in the active function area. The reference-level value can be changed by using the data keys, the step keys, or the knob. When the desired calibration level is reached, STORE REF LVL may be pressed to store the new value in nonvolatile memory. If STORE REF LVL is not pressed, the new value remains in use until a power-on occurs.

MORE
1 OF 2

Accesses additional calibration and diagnostic functions, which are described below.

CRT ADJ
PATTERN

Displays a fixed pattern of lines and characters on the screen, each of which is used in setting the various adjustments in display hardware (such as vertical gain, blanking, and so on). Three of these adjustments—X POSN, Y POSN, and TRACE ALIGN—are available from the rear panel. Use the CRT alignment pattern and the above three adjustments to align the display. Refer to Figure 2-1. When this function is active, all front-panel keys are inactive except PRESET. Press EXIT to remove the pattern and return the analyzer to its previous state. For other display adjustments, refer to the Installation and Verification Manual for your analyzer.

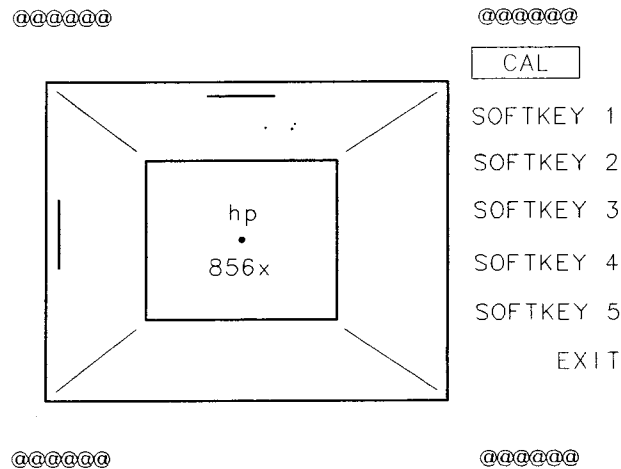

Figure 2-1. CRT Alignment Pattern

**FREQ
DIAGNOSE**

Displays a menu of diagnostic functions, described below, which allow various internal parameters of the analyzer to be retrieved.

Note



For an HP 8561B and HP 8563A in multiband sweeps, the frequency displayed corresponds to the local-oscillator start frequency of the band that was being swept when the key was pressed.

LO FREQ

Displays the first local-oscillator frequency corresponding to the current start-frequency.

**SAMPLER
FREQ**

Displays the sampling-oscillator frequency corresponding to the current start frequency.

**SAMPLER
HARMONIC**

Displays the sampler harmonic number corresponding to the current start-frequency.

**MAIN
ROLLER**

Displays the main-roller-oscillator frequency corresponding to the current start-frequency.

**OFFSET
ROLLER**

Displays the offset-roller-oscillator frequency corresponding to the current start-frequency. In narrow resolution bandwidths (10, 30, and 100 Hz), the frequency displayed corresponds to the frequency of the offset-roller-oscillator.

**TRANSFER
ROLLER**

Displays the transfer-roller-oscillator frequency corresponding to the current start-frequency.

**MORE
2 OF 2**

Accesses the previous menu of softkeys.

Auxiliary Control

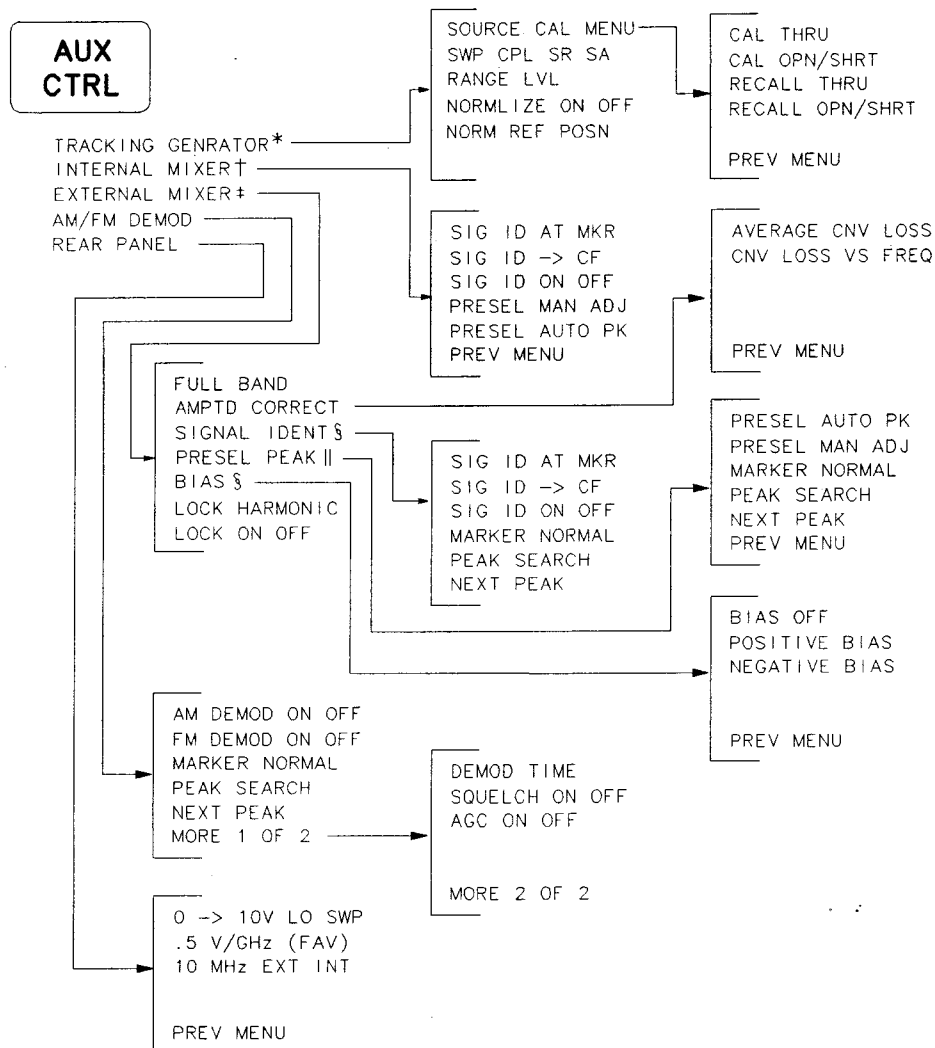

*For use with an external tracking generator only. See next page for built-in tracking generator (HP 8560A Option 002) softkey menu.

† The INTERNAL MIXER softkey and its lower-level softkeys are not available with an HP 8560A Option 002. However, only the INTERNAL MIXER softkey is available with an HP 8560A, its softkey menus are not.

‡ Not available with an HP 8560A Option 002.

§ Available only with unpreselected external mixing.

|| Available only with preselected external mixing.

AUX CTRL accesses a menu of auxiliary functions, such as tracking generator and demodulation, which are described below.

Note



The minimum resolution bandwidth that is supported for stimulus-response measurements is 300 Hz. If a tracking generator is active and a resolution bandwidth less than 300 Hz is selected, then the error message **TG/RBW INCOMPATIBLE** will flash in the message area.

**TRACKING
GENERATOR**

Not available with an HP 8560A Option 002.

Displays softkey menus only for use with an external tracking generator.

**SOURCE
CAL MENU**

Accesses a menu of softkeys that allow you to calibrate for frequency-response errors in test setups. Thru calibration is used when making transmission measurements, and open/short average calibration is used when making reflection measurements.

CAL THRU

Activates a procedure to store a thru calibration trace into trace B and into the nonvolatile memory of the spectrum analyzer (for future reference). When activated, the message **Connect THRU. Store when ready.** appears in the active function block. Once the thru is connected, press **STORE THRU**. The state of the thru information is stored in state register #9.

If the procedure needs to be interrupted at any time, press **ABORT**.

**CAL
OPN/SHRT**

Activates a procedure to store the average of an open and a short calibration into trace B and into the nonvolatile memory of the spectrum analyzer (for future reference). When activated, the message **Connect OPEN. Store when ready.** appears in the active function block. Once the open is connected, press **STORE OPEN**. **Connect SHORT. Average with open when ready.** will then appear in the active function block. Connect the short, then press **AVERAGE SHORT**. The state of the open/short average trace is stored in state register #8. However, it is necessary to have a directional device (for example, either a bridge or coupler) to perform return-loss measurements.

If this procedure needs to be interrupted at any time, press **ABORT**.

**RECALL
THRU**

Recalls the internally stored thru calibration trace into trace B. The instrument state is also set to the stored thru state.

**RECALL
OPN/SHRT**

Recalls the internally-stored open/short average calibration trace into trace B. The instrument state is also set to the stored open/short calibration state.

**PREV
MENU**

Accesses the previous menu of softkeys.

**SWP CPL
SR SA**

Allows the user to choose a stimulus-response (SR) or spectrum-analyzer (SA) auto-coupled sweep time. In stimulus-response mode, auto-coupled sweep times are usually much faster for swept-response measurements. Stimulus-response auto-coupled sweep times are typically valid in stimulus-response measurements when the system's frequency span is less than 20 times the bandwidth of the device under test. When a stimulus-response sweep time is chosen, an E appears in the special functions area at the left-hand side of the display screen.

**RANGE
LVL**

Activates the dynamic-range-level function which corresponds to the top of the display in dBm. **RANGE LVL** ensures that the displayed range is compression-free by adjusting the input attenuator and IF gain accordingly. **RANGE LVL** is equivalent to **REF LVL**, which is commonly used in signal-analysis measurements.

When in normalized mode **NORM REF LVL** and **NORM REF POSN** affect the value of the top of the display (that is, the top of screen does not necessarily represent the gain compression limit). If the actual measured signal is beyond the gain compression limit, or below the bottom line of the graticule, the error message **ERR 903 A > DLMT** will appear. Adjusting **RANGE LVL** until the error message disappears assures the user that the measured signal level is no longer beyond the measurement limits of the instrument. If the signal of interest is both above the gain compression limit and below the bottom graticule line, changing **RANGE LVL** does not clear the error message. Refer to Chapter 3 for a measurement example using **RANGE LVL**.

ERR 904 B > DLMT appears in normalized mode only if any of the following conditions occur:

- Any data point of the calibration trace is off-screen.
- No calibration has been performed after a preset.
- Trace B is blank.

To correct any of the above conditions, turn normalize off, and perform a **CAL THRU** or **CAL OPN/SHRT** operation.

RANGE LVL can be adjusted from +30 dBm to -120 dBm using the data keys, step keys, or the knob.

NORMLIZE
ON OFF

Activates (ON) or deactivates (OFF) the normalization routine for stimulus-response measurements. The routine subtracts the calibration trace stored in trace B from the active trace, trace A. The result is then offset by the normalized reference position. Results are displayed in trace A. The reference level value is displayed in dB when normalization is active.

When normalization is activated, an N appears in the special functions area at the left-hand side of the display screen. The **REF LVL** softkey under **AMPLITUDE** is replaced by **NORM REF LVL** in addition to **RANGE LVL** now being available.

Note

If a trace math function has been previously activated, turning normalize mode on deactivates the trace math function.

If a thru or open/short calibration state does not correspond to the current state when normalization is active (that is, have the same center frequency, start frequency, stop frequency, frequency span, or amplitude scale), the error message **ERR 902 BAD NORM** appears.

NORM REF
POSN

Allows the user to adjust the normalized reference position that corresponds to the position on the graticule where the difference between the measured and calibrated traces resides. The normalized reference position may be adjusted between 0.0 and 10.0 using the data keys, step keys, or knob.

The normalized reference position adjustment allows measured data to be compared to a reference position, where the difference between the measured data and the reference position represents the gain or loss of the device under test.

When normalization is on, two indicators (-> and <-) appear on-screen to mark the location of the normalized reference position.

HP 8560A Option 002

AUX CTRL

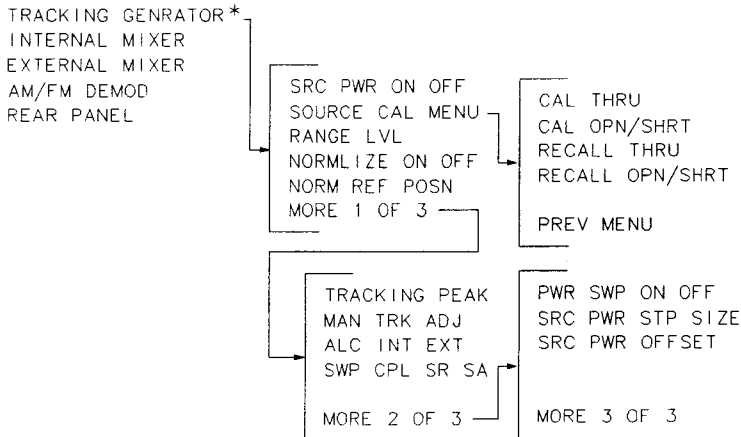

* HP 8560A Option 002 softkey menu.

Listed below are the function descriptions for the built-in tracking generator of an HP 8560A Option 002.

Note



The minimum resolution bandwidth that is supported for stimulus-response measurements is 300 Hz. If a tracking generator is active and a resolution bandwidth less than 300 Hz is selected, then the error message **TG/RBW INCOMPATIBLE** will flash in the message area.

TRACKING GENERATOR

HP 8560A Option 002 only.

Displays softkey menus only for use with a built-in tracking generator. When selected, **TRACKING GENERATOR** also displays the RF power level of the tracking generator in the active function block.

SRC PWR ON OFF

Activates (ON) or deactivates (OFF) the output power of the tracking generator. The power level can then be adjusted using the data keys, step keys, or knob. The output power level can be varied from -10 dBm to +2.8 dBm, with 0.1 dB resolution.

When source power is on, a **G** appears in the special functions area at the left-hand side of the display screen.

Note



The tracking generator warm-up period begins when the source power is set to ON and the **G** is displayed in the special functions area. The tracking generator is not turned on automatically when the analyzer is turned on, unless the power-on state is specified as having the source power set to ON.

**SOURCE
CAL MENU**

Accesses a menu of softkeys that allow the user to calibrate for frequency-response errors in test setups. Thru calibration is used when making transmission measurements, and open/short average calibration is used when making reflection measurements.

CAL THRU

Activates a procedure to store a thru calibration trace into trace B and into the nonvolatile memory of the spectrum analyzer (for future reference). When activated, the message **Connect THRU. Store when ready.** appears in the active function block. Once the thru is connected, press **STORE THRU**. The state of the thru information is stored in state register #9.

If the procedure needs to be interrupted, press **ABORT**.

**CAL
OPN/SHRT**

Activates a procedure to store the average of an open and a short calibration into trace B and into the nonvolatile memory of the spectrum analyzer (for future reference). When activated, the message **Connect OPEN. Store when ready.** appears in the active function block. Once the open is connected, press **STORE OPEN. Connect SHORT. Average with open when ready.** will then appear in the active function block. Connect the short, then press **AVERAGE SHORT**. The state of the open/short average trace is stored in state register #8.

If this procedure needs to be interrupted at any time, press **ABORT**.

**RECALL
THRU**

Recalls the internally stored thru calibration trace into trace B. The instrument state is also set to the stored thru state.

**RECALL
OPN/SHRT**

Recalls the internally stored open/short average calibration trace into trace B. The instrument state is also set to the stored open/short calibration state.

**PREV
MENU**

Accesses the previous menu of softkeys.

**RANGE
LVL**

Activates the dynamic-range-level function which corresponds to the top of the display in dBm. **RANGE LVL** ensures that the displayed range is compression-free by adjusting the input attenuator and IF gain accordingly. **RANGE LVL** is equivalent

to **REF LVL** which is commonly used in signal-analysis measurements.

When in normalized mode, **NORM REF LVL** and **NORM REF POSN** affect the value of the top of the display (that is, the top of screen does not necessarily represent the gain compression limit). If the actual measured signal is beyond the gain compression limit, or below the bottom line of the graticule, the error message **ERR 903 A > DLMT** will appear. Adjusting **RANGE LVL** until the error message disappears assures the user that the measured signal level is no longer beyond the measurement limits of the instrument. If the signal of interest is both above the gain compression limit and below the bottom graticule line, changing **RANGE LVL** does not clear the error message. Refer to Chapter 3 for a measurement example using **RANGE LVL**.

ERR 904 B > DLMT appears in normalized mode only if any of the following conditions occur:

- Any data point of the calibration trace is off-screen.
- No calibration has been performed after a preset.
- Trace B is blank.

To correct any of the above conditions, turn normalize off, and perform a **CAL THRU** or **CAL OPN/SHRT** operation.

RANGE LVL can be adjusted from +30 dBm to -120 dBm using the data keys, step keys, or the knob.

NORMLIZE
ON OFF

Activates (ON) or deactivates (OFF) the normalization routine for stimulus-response measurements. The routine subtracts the calibration trace stored in trace B from the active trace, trace A. The result is then offset by the normalized reference position. Results are displayed in trace A. The reference level value is displayed in dB when normalization is active.

When normalization is activated, an **N** appears in the special functions area at the left-hand side of the display screen. The **REF LVL** softkey under **AMPLITUDE** is replaced by **NORM REF LVL**.

Note



If a trace math function has been previously activated, turning normalize mode on deactivates the trace math function.

If a thru or open/short calibration state does not correspond to the current state when normalization is active (that is, have the same center frequency, start frequency, stop

frequency, frequency span, or amplitude scale), the error message ERR 902 BAD NORM appears.

**NORM REF
POSN**

Allows the user to adjust the normalized reference-position that corresponds to the position on the graticule where the difference between the measured and calibrated traces resides. The normalized reference-position may be adjusted between 0.0 and 10.0 using the data keys, step keys, or knob.

The normalized-reference-position adjustment allows measured data to be compared to a reference position, where the difference between the measured data and the reference position represents the gain or loss of the device under test.

When normalization is on, two indicators (-> and <-) appear on-screen to mark the location of the normalized reference position.

**MORE
1 OF 3**

Accesses additional tracking-generator functions, which are described below.

Note



Before making a stimulus-response measurement, care must be taken to maximize the tracking adjustment of the tracking generator to ensure amplitude accuracy.

**TRACKING
PEAK**

Activates a routine which automatically adjusts both the coarse and fine-tracking adjustments to obtain the peak response of the tracking generator on the spectrum-analyzer display. The routine uses a 300 Hz resolution bandwidth for peaking; therefore, narrowing the resolution bandwidth after a tracking peak has been done results in no tracking adjustment. Tracking peak is not needed for resolution bandwidths greater than or equal to 300 kHz.

Note



The tracking generator must be connected to the spectrum analyzer in order for tracking peak to function properly.

**MAN TRK
ADJ**

Allows the user to adjust the frequency of the tracking-generator oscillator manually using the step keys or knob. The tracking adjust is tuned to maximize the amplitude of the trace.

Once activated, either the coarse or fine adjustment can be made. **COARSE TRACK ADJ** can be adjusted in digital-to-analog-converter (DAC) values from 0 to 255 using the step keys or data keys. **FINE TRACK ADJ** can be adjusted from 0 to 255 (DAC values) using the knob.

Tracking error occurs when the output frequency of the tracking generator is not exactly matched to the input frequency of the spectrum analyzer. The resulting mixing

product from the spectrum analyzer input mixer is not at the center of the IF bandwidth. Any tracking errors may be compensated for through manual adjustments of the tracking generator's oscillator, or through an automatic tracking routine, **TRACKING PEAK**.

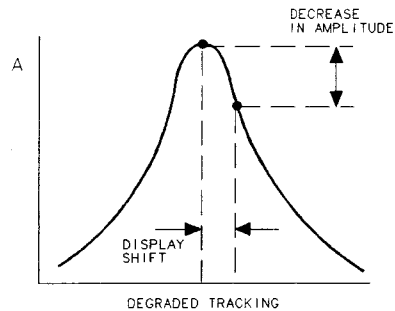

Figure 2-2. Tracking Error

ALC
INT EXT

Activates internal (INT) leveling or external (EXT) leveling. The external leveling input is located on the rear panel of the analyzer. Negative-polarity detectors are supported. External leveling increases the amplitude accuracy by improving the effective source match.

SWP CPL
SR SA

Allows the user to choose a stimulus-response (SR) or spectrum-analyzer (SA) auto-coupled sweep time. In stimulus-response mode, auto-coupled sweep times are usually much faster for swept-response measurements. Stimulus-response auto-coupled sweep times are typically valid in stimulus-response measurements when the system's frequency span is less than 20 times the bandwidth of the device under test. When a stimulus-response sweep time is chosen, an **E** appears in the special functions area at the left-hand side of the display screen.

MORE
2 OF 3

Accesses additional tracking-generator functions, which are described below.

PWR SWP
ON OFF

Activates (ON) or deactivates (OFF) the power-sweep function, where the output power of the tracking generator is swept over the power-sweep range chosen. The value of the power-sweep range is displayed in the active function block, when **PWR SWP ON OFF** is turned on. The power-sweep range can be set from 0 to 12.8 dB; however, the power-sweep range specified under warranty is 10 dB. It can be adjusted using the data keys, step keys, or knob.

The output power of the tracking generator is swept according to the sweep rate of the spectrum analyzer.

Power-sweep measurements are particularly useful in making gain compression or output power versus frequency measurements.

**SRC PWR
STP SIZE**

Allows the user to set the step size of the source power level, source power offset, and power-sweep range functions. The step size may be values from 0.1 dB to 12.8 dB.

**SRC PWR
OFFSET**

Allows the user to offset the displayed power of the tracking generator. Offset values may range from -100 dB to +100 dB.

Using the source-power-offset capability of the tracking generator allows you to take system losses into account, thereby displaying the actual power delivered to the device under test.

**MORE
3 OF 3**

Accesses the previous menu of softkeys.

AUX CTRL Softkey Menus continued

Note



The **INTERNAL MIXER** softkey and its lower-level softkeys are not available with an HP 8560A Option 002. However, the **INTERNAL MIXER** softkey is available with a standard HP 8560A; its softkey menus are not.

**INTERNAL
MIXER**

Displays the internal mixer softkey menu, which is described below, when using an HP 8561B or HP 8563A. When using external mixers, this softkey returns the spectrum analyzer to its internal mixing mode with an HP 8560A, an HP 8561B, or an HP 8563A.

**SIG ID
AT MKR**

Activates a signal-identification function that locates the frequency and harmonic number of the mixer response. Place a marker on the desired signal, then activate **SIG ID AT MKR**. The frequency of the signal and the LO harmonic mixing number appear in the active function block. If the function cannot identify the signal, either one of two messages, **NOT FOUND** or **LOST SIGNAL**, is displayed in the active function block.

If the analyzer traces are in states other than clear-write, then no action takes place and the message **ACTIVATE TRACE** appears.

**SIG ID
-> CF**

Sets the center frequency to the frequency obtained from the softkey **SIG ID AT MKR**. If the frequency is outside the range of the analyzer, no action takes place. If no signal identification has previously been performed, the message **DO: SIG ID AT MKR** momentarily appears in the active function block, and no other action takes place. Use this function only after executing **SIG ID AT MKR**.

SIG ID
ON OFF

Switches the manual signal-identification function ON and OFF. When ON, this function employs a frequency-shift method of identifying signals. Displayed signals are shifted horizontally and vertically on alternate sweeps. Signals that are correct for the selected harmonic band are shifted less than 50 kHz. In addition, all signals are shifted downward in amplitude by approximately one division, regardless of scale. This routine is only effective for signal identification in certain spans; the user must ensure that a proper span is selected. (To ensure accuracy, limit the frequency span to less than 20 MHz.)

PRESEL
MAN ADJ

Allows the user to adjust the preselector tracking. The HP 8561B is preselected from 2.75 GHz to 6.5 GHz, and from 2.75 GHz to 22 GHz (26.5 GHz with Option 026) for an HP 8563A. Place a marker on the desired signal on a trace, then press **PRESEL MAN ADJ**. The current preselector tracking number, which is displayed in the active function block, can be changed using the data keys, the step keys, or the knob. The value ranges from 0 to 255. If no marker is active, pressing **PRESEL MAN ADJ** automatically activates a marker at the peak. Executing the function affects data in the current data table (which may be data from either the user or the factory data tables). To save this data, use the **SAVE PRSEL PK** softkey found under **SAVE**.

The **PRESEL MAN ADJ** softkey appears under three different menus—**AMPLITUDE**, **INTERNAL MIXER**, and **EXTERNAL MIXER**. This **PRESEL MAN ADJ** softkey is only available for use with internal mixing. Refer to the **PRESEL MAN ADJ** softkey under the **EXTERNAL MIXER** menu of functions for preselected external mixers.

Note



When **PRESET** is pressed, the preselector data stored by the user does not change. However, the factory settings now become active.

Factory preselector data always takes precedence over user-activated preselected data, unless the user data is explicitly recalled using **RECALL PRSEL PK**. For more information on storing and recalling preselector data, refer to the **SAVE PRSEL PK** and **RECALL PRSEL PK** softkeys.

PRESEL
AUTO PK

Automatically peaks the preselector on a desired signal on a trace, when tuned above band 0. Set the trace to clear-write mode, place a marker on the desired point, then press **PRESEL AUTO PEAK**. The peaking routine zooms to zero span, peaks the preselector tracking, then returns to the original span. To read the new preselector peaking number, press **PRESEL MAN ADJ**.

The **PRESEL AUTO PK** softkey appears under three different menus—**AMPLITUDE**, **INTERNAL MIXER**, and **EXTERNAL MIXER**. This **PRESEL AUTO PK** softkey is only available for use with internal mixing. Refer to the **PRESEL AUTO PK** softkey under the **EXTERNAL MIXER** menu of functions for preselected external mixers.

**PREV
MENU**

Accesses the previous menu of softkeys.

**EXTERNAL
MIXER**

Accesses a menu of functions that allow you to extend the frequency range using external mixers. These functions are described below.

Note



No external mixing capabilities are available with an HP 8560A Option 002. 10 Hz, 30 Hz, and 100 Hz resolution bandwidths are not available with external mixers.

**FULL
BAND**

Allows you to select a commonly used frequency band above 18 GHz. These bands are shown in Table 2-3. Use the step keys or the knob to select a desired frequency band; the selected band appears in the active function block. Activating **FULL BAND** also activates the harmonic-lock function, which is described below.

**AMPTD
CORRECT**

Displays a menu of functions that set conversion losses and flatness data.

**AVERAGE
CNV LOSS**

Displays the mean conversion loss for the current harmonic and allows you to enter new conversion loss data. In a full frequency band (such as K band), the mean conversion loss is defined as the minimum loss plus the maximum loss for that band divided by two. To change the maximum and minimum values, use the **CNV LOSS VS FREQ** softkey. Any change to the average conversion loss also affects the flatness data, which is described below.

The default conversion loss value for each band is 30 dB.

**CNV LOSS
VS FREQ**

Displays the stored conversion loss for a specific frequency in the current band. This allows amplitude correction to be entered to compensate for changes in conversion loss with frequency. To enter a new value, use the data keys. To change the displayed frequency, use the step keys. Any changes to the data also affect the mean conversion loss stored under **AVERAGE CNV LOSS**. Table 2-4 shows

the number of flatness points for each band and the default flatness values. To view the correction, connect a 310.7 MHz signal of a known amplitude (approximately -30 dBm) to the IF input and set the analyzer to sweep the associated band.

Table 2-2.
Flatness Points and Conversion Losses for
Frequencies above 18 GHz

Frequency Band	Frequency Range (GHz)	Number of Flatness Points	Point Spacing	Conversion Loss
K	18.0 to 26.5	6	2 GHz	30 dB
A	26.5 to 40.0	8	2 GHz	30 dB
Q	33.0 to 50.0	7	3 GHz	30 dB
U	40.0 to 60.0	6	4 GHz	30 dB
V	50.0 to 75.0	6	5 GHz	30 dB
E	60.0 to 90.0	7	5 GHz	30 dB
W	75.0 to 110.0	8	5 GHz	30 dB
F	90.0 to 140.0	6	10 GHz	30 dB
D	110.0 to 170.0	7	10 GHz	30 dB
G	140.0 to 220.0	9	10 GHz	30 dB
Y	170.0 to 260.0	7	15 GHz	30 dB
J	220.0 to 325.0	8	15 GHz	30 dB

PREV
MENU

Displays the previous menu of softkeys.

SIGNAL
IDENT

Displays a menu of signal-identification functions, which are described below.

SIG ID
AT MKR

Activates a signal-identification function that locates the frequency and harmonic number of the mixer response. Place a marker on the desired signal, then activate **SIG ID AT MKR**. The frequency of the signal and the LO harmonic mixing number appear in the active function block. If the function cannot identify the signal, either one of two messages, **NOT FOUND** or **LOST SIGNAL**, is displayed in the active function block. If the analyzer traces are in states other than clear-write mode, then no action takes place and the message **ACTIVATE TRACE** appears.

During the signal-identification routine, the **SIG ID AT MKR** softkey is replaced with the **STOP SIG ID** softkey.

SIG ID
-> **CF**

Sets the center frequency to the frequency obtained from the softkey **SIG ID AT MKR**. If the frequency is outside the range of the analyzer, no action takes place. If no signal identification has previously been performed, the message DO: SIG ID AT MKR momentarily appears in the active function block, and no other action takes place. Use this function only after executing **SIG ID AT MKR**.

SIG ID
ON OFF

Switches the manual signal identification function ON and OFF. When ON, this function employs a frequency shift method of identifying signals. Displayed signals are shifted horizontally and vertically on alternate sweeps. Signals that are correct for the selected harmonic band are shifted less than 50 kHz. In addition, all signals are shifted downward in amplitude by approximately one division, regardless of scale. This routine is only effective for signal identification in certain spans; the user must ensure that a proper span is selected. (To ensure accuracy, limit the frequency span to less than 20 MHz.)

MARKER
NORMAL

Activates a single marker and places it at the center of the trace. This softkey is also annotated as **MARKER DELTA**, if delta-marker mode has been previously activated by the **MARKER DELTA** softkey under the **(MKR)** menus.

If one marker is already on, no operation takes place. If two markers are on (as in **MARKER DELTA** mode), **MARKER NORMAL** deletes the anchor marker and makes the active one the new, single marker. The marker reads the amplitude and the frequency (or the relative time, when the frequency span equals 0 Hz), and displays these values in the active function block and in the upper-right corner of the display. To move the marker, use either the knob, the step keys, or the data keys.

The marker reads data from the currently active trace. (An active trace is one in either

the clear-write or max-hold mode; this may be either trace A or trace B.) If both traces are active, or if both traces are in view mode, the marker reads data from trace A.

**PEAK
SEARCH**

Places a marker on the highest point on a trace. The frequency and amplitude of the marker are displayed in the upper-right corner of the screen; **PEAK SEARCH** does not alter the active function.

**NEXT
PEAK**

Moves the active marker to the next highest trace point relative to the current marker position. This function finds successively lower peaks when the key is pressed repeatedly.

**PRESEL
PEAK**

Available only with preselected external mixing.

Displays the *preselected* external mixer softkey menu, which is described below. This softkey menu is only available when the **EXT MXR PRE UNPR** softkey under **(CONFIG)** is set to “preselected” mode.

Note



The **PRESEL PEAK** softkey and its lower-level softkeys are only for use with preselected external mixers. The preselected configuration must initially be set up using the **EXT MXR PRE UNPR** softkey under **(CONFIG)**.

**PRESEL
AUTO PK**

Automatically peaks the preselector of the external mixer on a desired signal on a trace. Set the trace to clear-write mode, place a marker on the desired point, then press **PRESEL AUTO PK**. The peaking routine zooms to zero span, peaks the preselector tracking, then returns to the original span. To read the new preselector peaking number, press **PRESEL MAN ADJ**.

The **PRESEL AUTO PK** softkey appears under three different menus—**(AMPLITUDE)**, **INTERNAL MIXER**, and **EXTERNAL MIXER**. This **PRESEL AUTO PK** softkey is only available for use with preselected external mixing. Refer to the **PRESEL AUTO PK** softkey under **(AMPLITUDE)** or the **INTERNAL MIXER** menu of functions for use with internal mixers.

**PRESEL
MAN ADJ**

Allows the user to adjust the external preselector tracking. Pressing **PRESEL MAN ADJ** causes the preselector tracking number that applies to the marker frequency to be displayed in the active function block. If no marker is active, pressing **PRESEL MAN ADJ** automatically activates a marker at the peak.

When the tracking number is displayed in the active function block, it can be changed using the data keys, the step keys, or the knob. This tracking number ranges from 0 to 255. It is initialized to 128 when entering the external mixer mode of operation or whenever the band number is changed. Changing the tracking number affects the data in the current data table which may be a previously saved user data table. The resulting value after changing this function is only valid for the current band. To save this data, use the **SAVE PRESEL PK** softkey found under **SAVE**. This overwrites any previously saved preselector data regardless of whether that data was generated while using internal or external preselectors.

The **PRESEL MAN ADJ** softkey appears under three different menus—**AMPLITUDE**, **INTERNAL MIXER**, and **EXTERNAL MIXER**. This **PRESEL MAN ADJ** softkey is only available for use with preselected external mixing. Refer to the **PRESEL MAN ADJ** softkey under **AMPLITUDE** or the **INTERNAL MIXER** menu of functions for use with internal mixers.

**MARKER
NORMAL**

Activates a single marker and places it at the center of the trace. This softkey is also annotated as **MARKER DELTA**, if delta-marker mode has been previously activated by the **MARKER DELTA** softkey under the **MKR** menus.

If one marker is already on, no operation takes place. If two markers are on (as in **MARKER DELTA** mode), **MARKER NORMAL** deletes the anchor marker and makes the active one the new, single marker. The marker reads the amplitude and the frequency (or relative time, when the frequency span

equals 0 Hz), and displays these values in the active function block and in the upper-right corner of the display. To move the marker, use either the knob, the step keys, or the data keys.

The marker reads data from the currently active trace. (An active trace is one in either the clear-write or max-hold mode; this may be either trace A or trace B.) If both traces are active, or if both traces are in view mode, the marker reads data from trace A.

**PEAK
SEARCH**

Places a marker on the highest point on a trace. The frequency and amplitude of the marker are displayed in the upper-right corner of the screen; **PEAK SEARCH** does not alter the active function.

**NEXT
PEAK**

Moves the active marker to the next highest trace point relative to the current marker position. This function finds successively lower peaks when the key is pressed repeatedly.

**PREV
MENU**

Displays the previous menu of softkeys.

BIAS

Available only with unpreselected external mixers.

Displays a menu of functions that allow you to select external-mixer bias. The bias is provided on the center conductor of the IF INPUT connector on the front panel. These functions are described below.

Caution



External mixers that require bias may be damaged by the open-circuit bias voltage that can be as great as ± 3.5 V through a source resistance of 300 ohms. Such voltage may appear when recalling an instrument state in which an active bias has been stored.

Note



The bias value that appears on the spectrum analyzer display is expressed in terms of short-circuit current (that is, the amount of current that would flow if the center conductor of the IF INPUT were shorted to ground). The actual amount of current flowing into the mixer will be less.

**BIAS
OFF**

Turns off the external-mixer bias.

**POSITIVE
BIAS**

Selects positive mixer bias for an external mixer. This value, which can be entered using the data keys, the step keys, or the knob, appears in the active function block and is expressed in milliamps. When the bias is

greater than 0 mA, a + appears on the left edge of the display.

**NEGATIVE
BIAS**

Selects negative mixer bias for an external mixer. This value, which can be entered using the data keys, the step keys, or the knob, appears in the active function block and is expressed in milliamps. When the bias is less than 0 mA, a - appears on the left edge of the display.

**PREV
MENU**

Displays the previous menu of softkeys.

**LOCK
HARMONIC** and
**LOCK
ON OFF**

Displays the current harmonic number. A harmonic number refers to the local-oscillator harmonic that is used to sweep a specific frequency band. These numbers are shown in Table 2-3. When **LOCK ON OFF** is ON, only center frequencies and spans that fall within the frequency band of the current harmonic may be entered. When **FULL SPAN** under **SPAN** is activated, the span is limited to the frequency band of the selected harmonic.

When **LOCK ON OFF** is OFF, more than one harmonic can be used to sweep across a desired span. For example, with **LOCK ON OFF** set to OFF, sweep a span from 26.5 GHz to 60 GHz. In this case, the spectrum analyzer will automatically sweep first using 8- and then using 10-. When **FULL SPAN** is active and **LOCK HARMONIC** is OFF, the entire range of external mixing for the selected band appears on the display.

Table 2-3.
Mixing Harmonics for Frequencies above 18 GHz

Frequency Band	Frequency Range (GHz)	Mixing Harmonic	Conversion Loss (Default)
K	18.0 to 26.5	6-	30 dB
A	26.5 to 40.0	8-	30 dB
Q	33.0 to 50.0	10-	30 dB
U	40.0 to 60.0	10-	30 dB
V	50.0 to 75.0	14-	30 dB
E	60.0 to 90.0	16-	30 dB
W	75.0 to 110.0	18-	30 dB
F	90.0 to 140.0	24-	30 dB
D	110.0 to 170.0	30-	30 dB
G	140.0 to 220.0	36-	30 dB
Y	170.0 to 260.0	44-	30 dB
J	220.0 to 325.0	54-	30 dB

**AM/FM
DEMODO**

Accesses a menu of demodulation functions, which are described below. When demodulation is activated, the demodulated signal is output to the built-in speaker and phone jack whose output is on the rear panel.

**AM DEMOD
ON OFF**

Not available in normalized mode.

Turns AM demodulation ON or OFF. If no marker is active and the frequency span is greater than 0 Hz, pressing **AM DEMOD ON OFF** automatically places a marker at the center of the trace and demodulates the signal at that marker position. Activating AM demodulation turns off FM demodulation, if it is on. When the frequency span is greater than 0 Hz, a 10 kHz resolution bandwidth is used during demodulation, regardless of the bandwidth annotated on the screen. When the span is equal to 0 Hz, the displayed bandwidth is used. In either case the video bandwidth is not applied to the demodulation.

**FM DEMOD
ON OFF**

Not available in normalized mode.

Turns FM demodulation ON or OFF. If no marker is active and the frequency span is greater than 0 Hz, pressing **FM DEMOD ON OFF** automatically places a marker at the center of the trace and demodulates the frequency at that marker position. Turning FM demodulation on turns off AM demodulation, if it is active. When the frequency span is greater than 0 Hz, a 100 kHz bandwidth is used during the demodulation, regardless of the bandwidth annotated on the screen. When the span is equal to 0 Hz, the displayed bandwidth is used. In either case, the video bandwidth is not applied to the demodulation.

**MARKER
NORMAL**

Activates a single marker and places it at the center of the trace. If one marker is already on, no operation takes place. If two markers are on (as in **MARKER DELTA** mode), **MARKER NORMAL** deletes the anchor marker and makes the active one the new, single marker. The marker reads the amplitude and the frequency (or the relative time, when the frequency span equals 0 Hz), and displays these values in the active function block and in the upper-right corner of the display. To move the marker, use either the knob, the step keys, or the data keys.

The marker reads data from the currently active trace. (An active trace is one in either the clear-write or max-hold mode; this may be either trace A or trace B.) If both traces are active, or if both traces are in view mode, the marker reads data from trace A.

**PEAK
SEARCH**

Places a marker on the highest point on a trace. The frequency and amplitude of the peak-search marker are displayed in the upper-right corner of the screen.

**NEXT
PEAK**

Moves the active marker to the next highest trace point relative to the current marker position. This function finds successively lower peaks when the key is pressed repeatedly.

**MORE
1 OF 2**

Accesses a menu of additional demodulation functions.

**DEMOD
TIME**

Adjusts the duration of demodulation between successive sweeps when the span is greater than 0 Hz. The time ranges from 0.1 seconds to 60 seconds; the default value is 1 second. When the frequency span equals 0 Hz, demodulation is continuous, except for transients during retrace. To avoid these transients, place the analyzer in single-trigger mode with span equal to 0 Hz.

**SQUELCH
ON OFF**

Adjusts the squelch level. The value is displayed in the active function block, in dBm. The squelch level is also indicated by a dashed line across the display. A marker must be active and located above the squelch line for demodulation to occur when squelch is on. Note that in zero span, squelch for AM is inactive.

**AGC
ON OFF**

Switches automatic gain control (AGC) ON or OFF. AGC keeps the volume relatively constant during AM demodulation. AGC operates only during AM demodulation and when the frequency span is greater than 0 Hz.

**MORE
2 OF 2**

Displays the previous menu of softkeys.

**REAR
PANEL**

Accesses the functions that choose which signal is present at the designated rear-panel connectors. Selection of 0 → 10V or 0.5V/GHz is not changed with pressing **PRESET**.

If the preselected external mixer mode is selected, rear-panel output J8 of the analyzer is automatically switched to the 0.5V/GHz (FAV) mode with an output of 1.5 V/GHz of the LO frequency. The 1.5 V/GHz of the LO frequency definition is required for the HP 11974 Series preselected external mixers.

**0 → 10V
LO SWP**

Specifies the 0 to 10 volt ramp that corresponds to the sweep ramp that tunes the local oscillator at the rear-panel sweep output J8, LO SWP|0.5V/GHz.

**.5 V/GHz
(FAV)**

Specifies a 0.5 volts per GHz sweep output, which is also referred to as the frequency analog voltage (FAV), at the rear-panel sweep output J8, LO SWP|0.5V /GHz. When using an HP 8560A, HP 8561B, or HP 8563A with a tracking generator such as an HP 85640A, this softkey must be activated.

**10 MHz
EXT INT**

Allows you to select either an internal frequency reference or your own external frequency reference. An external reference must be 10 MHz ±100 Hz at a nominal amplitude of 0 dBm (limits are from -2 dBm to +10 dBm). The external

reference must be connected to J9, 10 MHz REF IN/OUT, on the rear panel. An X displayed on the left edge of the display denotes external reference mode.

Note



If an external frequency reference is selected but not supplied to the rear panel, hardware error messages are displayed. Refer to the Installation and Verification Manual for more information.

**PREV
MENU**

Displays the previous menu of softkeys.

Copy

COPY

COPY activates the function that transfers display data to an HP-IB device that has been selected with the **COPY DEV PRNT PLT** softkey under the **CONFIG** key. Refer to softkey function descriptions under **CONFIG** for more information on how to plot or print an output.

COPY allows either a black and white or color print of the entire display screen, or a plot of the entire display screen. Softkeys cannot be printed or plotted.

Module

MODULE

MODULE gives access to additional functions of an option module, such as the HP 85629B Test and Adjustment Module or the HP 85620A Mass Memory Module, when the module is connected to J3, OPTION MODULE, on the rear of the spectrum analyzer. If an option module is not connected when the **MODULE** key is pressed, the **MODULE NOT FOUND** message appears. For specific information on operating an option module, refer to the operating manual for that module.

Save

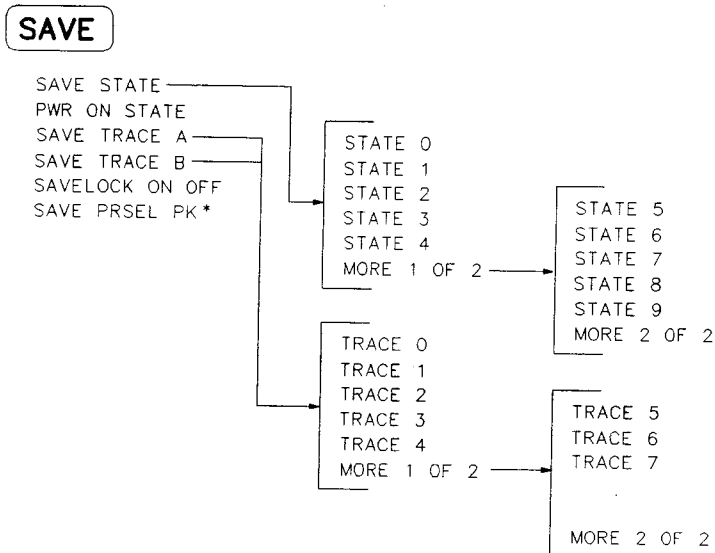

* Available only with preselected external mixing and HP 8561B and HP 8563A internal mixing.

SAVE accesses a menu of softkeys that allow you to save instrument-state data and trace data. These functions are described below.

SAVE STATE

Displays a menu of 10 registers in which the current instrument state can be stored. The save-state registers appear on two menus: **STATE 0** through **STATE 4** on the first page, and **STATE 5** through **STATE 9** on the second page. To store the current instrument state in a desired register, press the softkey next to the register number, or enter the number using the data keys. Terminate the entry with any units key (**Hz**, **kHz**, and so on).

If a stored state has a title, the first sixteen characters of the title are used as the softkey annotation for that register. The register annotation appears in two rows of eight characters each. For example, if the data stored in register 0 has the title "Harmonic Test," the softkey annotation **STATE 0** is replaced with the text **Harmonic Test**.

Note



State registers #8 and #9 are used to store normalization traces. Refer to tracking-generator softkey descriptions in this chapter for more information.

PWR ON STATE

Saves the current instrument state in the power-on register. The spectrum analyzer is then set to this state whenever **LINE** is switched on. The same state can be retrieved with **POWER ON**, available from the **RECALL** menu.

SAVE TRACE A

Displays a menu of eight registers in which the current contents of trace A can be stored. The save-trace registers appear on two menus: **TRACE 0**

through **TRACE 4** on the first page, and **TRACE 5** through **TRACE 7** on the second page. To store current trace A data in a desired register, press the softkey next to the register number, or enter the number using the data keys. Terminate the entry with any units key (**Hz**), (**kHz**), and so on).

Note

SAVE TRACE A and **SAVE TRACE B** use exactly the same eight save-trace registers in which to store trace data. Be careful not to overwrite previously saved trace data.

Trace-registers 5, 6, and 7 should not be used when using an HP 85620A Mass Memory Module. These trace registers are used by the module and may be overwritten if trace data has been previously stored in them.

SAVE TRACE B

Displays a menu of eight registers in which the current contents of trace B can be stored. The save-trace registers appear on two menus: **TRACE 0** through **TRACE 4** on the first page, and **TRACE 5** through **TRACE 7** on the second page. To store current trace A data in a desired register, press the softkey next to the register number, or enter the number using the data keys. Terminate the entry with any units key (**Hz**), (**kHz**), and so on).

SAVELOCK ON OFF

Prevents storing any new data in the state or trace registers. When **SAVELOCK ON OFF** is ON, the registers are “locked”; the data in them cannot be erased or overwritten, although the data can be recalled. To “unlock” the registers and store new data, switch **SAVELOCK ON OFF** to OFF.

Note

When **PRESET** is pressed, the preselector data stored by the user does not change. However, the factory settings now become active.

Factory preselector data always takes precedence over user-activated preselected data, unless the user data is explicitly recalled using **RECALL PRSEL PK**. For more information on storing and recalling preselector data, refer to the **SAVE PRSEL PK** and **RECALL PRSEL PK** softkeys.

SAVE PRSEL PK

Preselected external mixing and HP 8561B and HP 8563A internal mixing only.

Saves the current preselector-peak data in the user data table. This does not affect the preselector data that is set at the factory or by service personnel. To recall saved data to the current data table, use either **FACTORY PRSEL PK** to recall the factory data table or **RECALL PRSEL PK** to recall the user data table. Both of these softkeys are located under **RECALL**. The three available tables of preselector data are described below.

- **Current Data Table** contains the data used to tune the preselector. The data is obtained from either the user data table or the factory data table. Use either the **PRESEL MAN ADJ** or **PRESEL AUTO PK** softkey (located under **AMPLITUDE**), or **INTERNAL MIXER**, **EXTERNAL MIXER** softkey menus of **AUX CTRL**) to modify the data in the current table. To save the data, use **SAVE PRSEL PK**. If the current data is not saved, it is lost when the

instrument is preset, turned off, or whenever bands are changed in the case of external mixing.

- **Factory Data Table** is the default data table for internal mixing. This data is set at the factory and can only be changed by service personnel. This data is sent to the current data table when **PRESET** is pressed. The data in this table is sufficient for virtually all applications, since this is the table that allows the HP 8561B and HP 8563A to meet its published specifications.
- **User Data Table** is the current data table that was saved last and is recalled using the **RECALL PRESEL PK** softkey. The same user data table is used to store either internal or external preselector data. The preselector data saved depends on the current mode (internal or external). Therefore, when in external mixer mode and internal preselector data was previously saved, recalling the user data table will cause an **ERR 704 PRESELCT** error message. **ERR 704** also occurs when in internal mixer mode and external preselector data is recalled.

Recall

RECALL

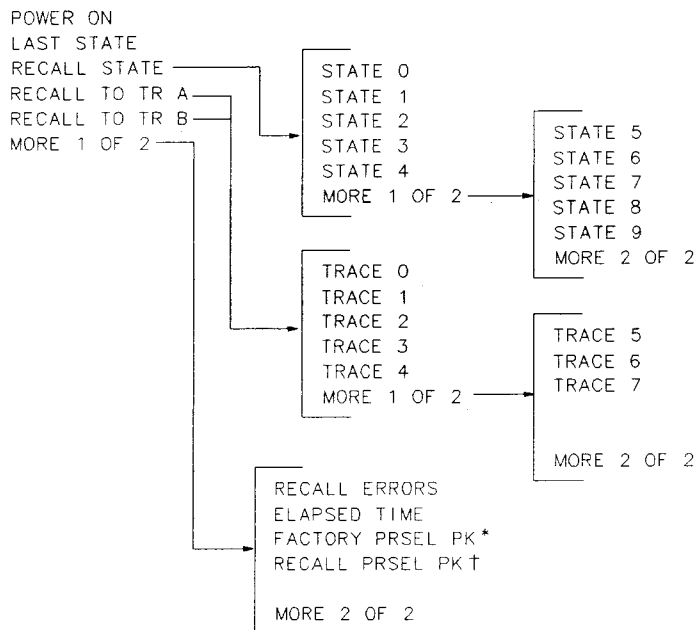

* Available only with internal mixing.

† Available only with preselected external mixing and HP 8561B and HP 8563A internal mixing.

RECALL accesses a menu of softkeys that allow you to recall stored instrument-state data and trace data. The softkeys are described below.

POWER ON

Sets the instrument state to the state stored in the power-on register, which is the same state that occurs when **LINE** is switched on. This state must be saved initially under the **SAVE** key.

LAST STATE

Recalls the instrument state that existed before **PRESET** was pressed or the power was turned off. This softkey function can also be accessed via the **PRESET** key.

RECALL STATE

Displays a menu of 10 registers from which the stored instrument states can be recalled and displayed on the spectrum analyzer screen. The recall-state registers appear on two menus: **STATE 0** through **STATE 4** on the first page, and **STATE 5** through **STATE 9** on the second page. To recall the data, press the softkey next to the desired register number, or enter the number using the data keys. Terminate the entry with any units (**Hz**), (**kHz**), and so on). If a recall-state register does not contain a previously-saved instrument state, the **NOT SAVED!** message appears.

If a stored state has a title, the first sixteen characters of the title are used as the softkey annotation for that register. The register annotation appears in two rows of eight characters each. For example, if the data previously stored

in register 0 has the title “Harmonic Test,” the softkey annotation STATE 0 is replaced with the text **Harmonic Test**.

Note

State registers #8 and #9 are used to store normalization traces. Refer to tracking-generator softkey descriptions in this chapter for more information.

**RECALL
TO TR A**

Displays a menu of eight registers from which trace data can be recalled and placed in trace A. The recall-trace registers appear on two menus: **TRACE 0** through **TRACE 4** on the first page, and **TRACE 5** through **TRACE 7** on the second page. To recall trace data from a desired register into trace A (B), press the softkey next to the register number, or enter the number using the data keys. Terminate the entry with any units key (**Hz**), (**kHz**), and so on). If a recall-trace register does not contain previously-saved trace data, the **NOT SAVED!** message appears.

**RECALL
TO TR B**

Displays a menu of eight registers from which trace data can be recalled and placed in trace B. The recall-trace registers appear on two menus: **TRACE 0** through **TRACE 4** on the first page, and **TRACE 5** through **TRACE 7** on the second page. To recall trace data from a desired register into trace A (B), press the softkey next to the register number, or enter the number using the data keys. Terminate the entry with any units key (**Hz**), (**kHz**), and so on). If a recall-trace register does not contain previously-saved trace data, the **NOT SAVED!** message appears.

**MORE
1 OF 2**

Accesses additional softkeys, which are described below.

**RECALL
ERRORS**

Displays the last error that has occurred. Use the step keys to cycle through accumulated errors. For a list of all error codes and additional error information, refer to “Error Messages” in Chapter 5 of the Installation and Verification Manual. Also, a list of all error codes and messages can be found in Appendix E.

Hint

If you are using an external frequency reference and are incurring errors, be sure your external reference meets the requirements listed under “Characteristics” in Chapter 1 of the Installation and Verification Manual.

**ELAPSED
TIME**

Displays the cumulative operating time of the spectrum analyzer. The value, which is expressed in hours, appears in the active function block.

**FACTORY
PSEL PK**

Available only with internal mixing.
Restores the factory preselector-peaking data and makes this data the current preselected data. This data is stored in the factory data table and can only be changed by service personnel. For more information on the preselector data tables, refer to the **RECALL PSEL PK** softkey below.

Note

When **PRESET** is pressed, the preselector data stored by the user does not change. However, the factory settings now become active.

Factory preselector data always takes precedence over user-activated preselected data, unless the user data is explicitly recalled using **RECALL PRSEL PK**. For more information on storing and recalling preselector data, refer to the **SAVE PRSEL PK** and **RECALL PRSEL PK** softkeys.

**RECALL
PRSEL PK**

Preselected external mixing and HP 8561B and HP 8563A internal mixing only.

Recalls the preselector data that is stored by the user in the user data table. This data can be saved using the **SAVE PRSEL PK** softkey, found under the **SAVE** menu. The three available tables of preselector data are described below.

- **Current Data Table** contains the data used to tune the preselector. The data is obtained from either the user data table or the factory data table. Use either the **PRESEL MAN ADJ** or **PRESEL AUTO PK** softkey (located under **AMPLITUDE**, or **INTERNAL MIXER**, **EXTERNAL MIXER** softkey menus of **AUX CTRL**) to modify the data in the current table. To save the data, use **SAVE PRSEL PK**. If the current data is not saved, it is lost when the instrument is preset, turned off, or whenever bands are changed in the case of external mixing.
- **Factory Data Table** is the default data table for internal mixing. This data is set at the factory and can only be changed by service personnel. This data is sent to the current data table when **PRESET** is pressed. The data in this table is sufficient for virtually all applications, since this is the table that allows the HP 8561B and HP 8563A to meet its published specifications.
- **User Data Table** is the current data table that was saved last and is recalled using the **RECALL PRSEL PK** softkey. The same user data table is used to store either internal or external preselector data. The preselector data saved depends on the current mode (internal or external). Therefore, when in external mixer mode and internal preselector data was previously saved, recalling the user data table will cause an **ERR 704 PRESELCT** error message. **ERR 704** also occurs when in internal mixer mode and external preselector data is recalled.

**MORE
2 OF 2**

Accesses the previous menu of softkeys.

Measure

MEAS/
USER

FFT MEAS
POWER BANDWIDTH
MKBW-3
MKBW-6

MEAS/USER accesses the softkey functions that perform the measurements which are described below.

**FFT
MEAS**

Performs a discrete Fourier transform on the input signal. It is intended to convert zero-span information into the frequency domain, allowing the demodulated signal to be viewed as spectral data relative to the frequency of the modulation. However, performing a fast Fourier transform (FFT) on a frequency sweep will *not* provide time-domain results.

When **FFT MEAS** is pressed, the function sets the analyzer to sample-detection mode and takes a sweep to obtain a sample of the input signal. Then the spectrum analyzer executes a series of computations on the time-domain data to produce the frequency-domain results.

Note



Pressing **FFT MEAS** sets the analyzer into single-sweep mode. To leave the FFT measure mode, set the sweep to continuous by pressing **CONT** under either the **SWEEP** or **TRIG** key.

The FFT results are displayed on the spectrum analyzer in a 10 dB/division logarithmic scale. For the horizontal dimension, the frequency at the left side of the graph is 0 Hz, and at the right side is 300/sweep-time. Also, peak search marker is activated.

The FFT function is commonly used to measure AM in the presence of incidental FM. In this case, performing an FFT on the demodulated, zero-span AM signal, will result in a component (shown at 0 Hz) that depicts the power in the carrier of an AM signal. Other components are shown at the power level of the AM sidebands, with FM sidebands rejected. The amplitude accuracy of these sidebands is affected by the effective filtering of the resolution bandwidth filter (equivalent to a low-pass filter with half the resolution bandwidth) and the video filter.

Aliasing can occur when modulation rates on the carrier are higher than one-half the sample rate for the zero-span signal, or 300 divided by the sweep time. The aliasing can be reduced by using a narrow resolution or video bandwidth.

Note

Video, line, or external trigger should not be used with **FFT MEAS** due to a possible sweep occurring once the FFT measurement has been taken.

**OCCUPIED
POWER BW**

Integrates the power displayed and places the delta markers at the points containing 99 percent of the power. The power-bandwidth routine first computes the combined power of all signal responses contained in the trace. It then puts markers at the frequencies for which 0.5 percent of the power lies to the right of the right marker and to the left of the left marker. Thus, 99 percent of the power lies between the markers. The difference of the marker frequencies is the occupied 99% power bandwidth, and is displayed onscreen.

**3dB
POINTS**

When used remotely, this command finds the signal's bandwidth at 3 dB below the on-screen marker (if a marker is present) or the signal peak (if no on-screen marker is present). When using **3dB POINTS** manually, a peak search is automatically performed, and the 3 dB bandwidth of the largest signal onscreen is displayed in the message area.

**6dB
POINTS**

When used remotely, this command finds the signal's bandwidth at 6 dB below the on-screen marker (if a marker is present) or the signal peak (if no on-screen marker is present). When using **6dB POINTS** manually, a peak search is automatically performed, and the 6 dB bandwidth of the largest signal on-screen is displayed in the message area.

**ACP
MENU**

Available only with firmware date codes 910816 and later.

Accesses the adjacent channel power (ACP) menu of softkeys that measures the adjacent channel power ratio of a transmitter.

**AUTO ACP
MEASURE**

Measures the leakage of the transmitter into the adjacent channels. **AUTO ACP MEASURE** performs an automatic measurement which calculates the ratio of the leakage power in the adjacent channel to the total power transmitted by a transmitter. Using **AUTO ACP MEASURE** changes the instrument state to insure that a valid measurement is made. The instrument state parameters that can be affected are frequency span, resolution bandwidth, video bandwidth, and detection mode. Trace math and video averaging, if on, are turned off. Other instrument state parameters, including center frequency and reference level, are not affected.

The spectrum analyzer center frequency should be set to the transmitter intended center frequency. The reference level should be set to optimize the displayed range to minimize the number of data points above the top or below the bottom of the range of the chosen display scale. The display scale should be LOG 10 dB/division. The input attenuator should be set to optimize the tradeoff between analyzer-induced third-order intermodulation distortions and noise.

When **AUTO ACP MEASURE** is used, the display reflects the following:

- ACP ratio results in the lower channel (LOW) and upper channel (UP), located in the active function area,
- channel spacing (CSP) and channel bandwidth (CBW) parameters, located in the active function area, and
- total power transmitted (PWR Tx) and maximum adjacent channel power (MAX ACP), located in the display title area.

Refer to Figure 2-3 below for an illustration of how the channel bandwidth and channel spacing parameters are defined. For more detailed information regarding how an ACP measurement is determined, refer to “Adjacent Channel Power (ACP) Computations” at the end of the ACP softkey descriptions.

The adjacent channel power measurement, as performed by the spectrum analyzer using the setup from **AUTO ACP MEASURE**, responds to signals in an rms fashion. This means that the total power transmitted and adjacent channel power ratios are accurately reported, whether or not the transmitted signal contains tones, noise, or both. If the instrument state violates any of the following constraints, the response of **ACP COMPUTE** to signals is no longer rms, and errors of up to -2.51 dB can occur for noise-like signals:

- Video bandwidth is at least 10 times the resolution bandwidth.
- Detector mode is SAMPLE.
- Resolution bandwidth is less than or equal to 100 kHz.
- Video averaging is OFF.
- Neither MAX HOLD nor MIN HOLD trace mode is selected.

When **AUTO ACP MEASURE** is pressed and the measurement setup is suitable for rms detection, the following adjacent channel power message is briefly displayed in the active function area immediately before the measurement is made.

DETECTION:
RMS VOLTAGE
(POWER DETECTOR)

Note



Power detection is invoked during adjacent channel power calculations but is not available as a detector mode.

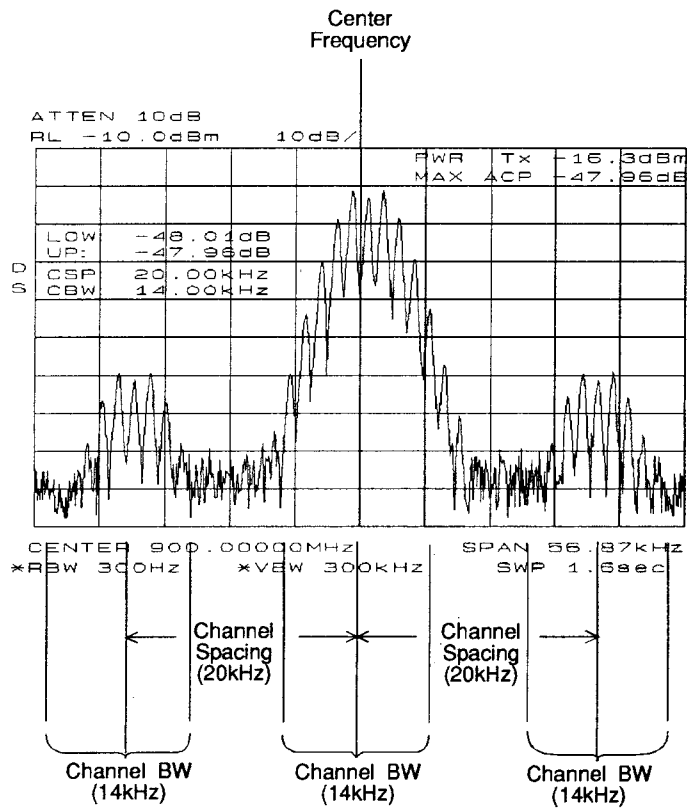

Figure 2-3. Channel Bandwidth Parameters

**ACP
COMPUTE**

Performs an adjacent channel power (ACP) computation on the current trace data without changing the instrument state settings. This computation operates exactly the same as that of **AUTO ACP MEASURE**, but allows the user to control the desired instrument state settings.

When **ACP COMPUTE** is pressed and the measurement setup is suitable for rms detection, the same rms voltage detection message displayed when using **AUTO ACP MEASURE** is displayed in the active function area. However, if the instrument state is unsuitable for rms detection, the following warning message is displayed.

******WARNING****
NOT RMS DETECTOR**

In addition to the warning message, the instrument-state parameter that is causing the warning will also be displayed. The instrument-state messages that may be displayed are:

**RBW \geq 300 kHz
VBW $<$ 10 \times RBW
DETECTOR MODE
MIN HOLD
MAX HOLD
VIDEO AVERAGE**

Even though a warning message with an invalid instrument-state parameter was indicated, the measurement is still made and the results are displayed in the active function area. If an invalid instrument-state parameter is suspected, the warning message can be viewed briefly by pressing the **ACP COMPUTE** softkey repeatedly. Computation results without rms detection can be accurate if the signals in the adjacent channels are CW-like, not noise-like. Also, some international standards for ACP measurements require the video bandwidth to be equal to the resolution bandwidth, which prohibits rms detection, while requiring the measurement to respond to the rms sum of all signals in the passband. If the video bandwidth is set according to this standard, the warning message will be displayed.

In addition to the warning messages for invalid instrument-state parameters listed above, the following three error messages may be observed in the lower right-hand corner of the display:

- ERR 908 BW>>SPCG indicates that the channel bandwidth is too wide, compared to the channel spacing, for a valid computation.
- ERR 909 SPAN<ACP indicates that the frequency span is too narrow to obtain a valid measurement.
- ERR 910 SPAN>ACP indicates that the frequency span is too wide, compared to the channel bandwidth, to obtain an accurate measurement.

If any of the three errors occur, the measurement is not completed. To correct the measurement, adjust your instrument state settings depending on the error that has occurred.

ACPGRAPH
ON OFF

Displays a graphical representation of the adjacent power channel power (ACP) ratio, for the selected channel bandwidth, as a function of the channel spacing. The graph can demonstrate how rapidly the ACP ratio changes with channel spacing. The upper graticule represents an ACP ratio of 0 dB. The vertical scale for the ACP graph is the same as the vertical scale for the spectrum trace, usually 10 dB/division. The horizontal scale represents the channel spacing, with 0 Hz spacing in the center and a scale factor that is the same as that for the spectrum trace, or the frequency span divided by 10 divisions.

The ACP graph is not defined for channel spacings where the graph is drawn at the bottom graticule line. For these points, the channel bandwidth would include frequencies beyond the edges of the screen, where no data was taken.

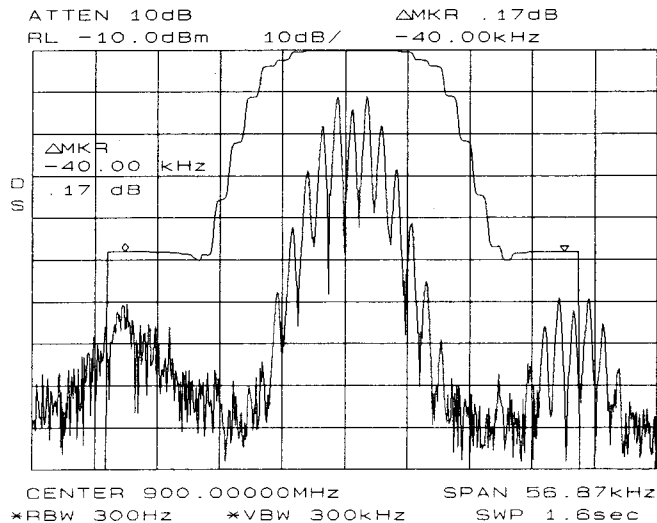

Figure 2-4. ACP Graph Display

**SPACING/
BANDWIDTH**

Accesses the channel spacing and channel bandwidth softkeys for use in the adjacent channel power measurements. The first three softkeys are common spacing and bandwidth pairs.

**12.5kHz/
8.5kHz**

Sets the channel spacing to 12.5 kHz and the channel bandwidth to 8.5 kHz.

**20.0kHz/
14.0kHz**

Sets the channel spacing to 20.0 kHz and the channel bandwidth to 14.0 kHz.

**25.0kHz/
16.0kHz**

Sets the channel spacing to 25.0 kHz and the channel bandwidth to 16.0 kHz.

**CHANNEL
SPACING**

Activates the channel spacing which regulates the spacing between transmitted signals. **CHANNEL SPACING** can be adjusted using the data keys, the step keys, or the knob.

**CHANNEL
BANDWIDTH**

Activates the channel bandwidth. **CHANNEL BANDWIDTH** can be adjusted using the data keys, the step keys, or the knob. When adjusting **CHANNEL BANDWIDTH**, if the selected channel bandwidth exceeds the channel spacing, the channel spacing increases as the channel bandwidth is incremented.

**PREV
MENU**

Displays the previous menu of softkeys.

EXIT ACP

Exits the adjacent channel power menu and restores the instrument-state settings that were previously active prior to entering the ACP menu.

Note



When exiting the ACP menu via pressing any other front-panel key, instrument-state settings are *not* restored.

Adjacent Channel Power (ACP) Instrument Setup

User settings of the reference level, input attenuation, and display scale are not changed by the ACP features, and must be set well for optimum dynamic range and thus accuracy.

Although “linear” and other logarithmic scales are supported, only the log 10 dB/division scale has adequate dynamic range for ACP measurements; thus, it should always be used.

The reference level (RL) should be chosen so that the signal neither exceeds the top nor the bottom of the fidelity-specified range of the chosen (10 dB/division) scale. When the signals in the channel are CW-like, the optimum RL is that for which the largest signal is at the RL.

When the signals in the channel are noise-like, as is the case for most digital modulations, the optimum RL depends on the range of the logarithmic amplifier and other parameters. The difference between the transmitter power and the reference level is given by:

$$(10 \text{ dB}) \log \left[\frac{RL}{P_{TX}} \right] = (10 \text{ dB}) \log \left[\frac{1.85 RBW}{ChBW} \right] + 0.439(\text{logrange} + ACP_{ratio})$$

where:

P_{TX} is the total transmitted power.

RBW is the spectrum analyzer resolution bandwidth.

ChBW is the channel bandwidth.

RL is the reference level power (note that the units must be power units, for example, mW, and match those of P_{TX}).

logrange is the specified range of the log amplifier, a positive number, usually between 70 and 100 dB.

ACP_{ratio} is the ratio of the adjacent channel power to the transmitter power, expressed in dB, and is always a negative number.

The setting of the input attenuator of the spectrum analyzer determines the tradeoff between the distortion errors and noise errors. The following equation expresses the optimum choice of input attenuation for a spectrum analyzer.

$$ATTN_{opt} = PdB_{TX} - (3.84 \text{ dB}) - \frac{1}{3} \left\{ DANL_{Ref} + 2ML_{Ref} + TODdB_{Ref} + (10 \text{ dB}) \log \left[\frac{ChBW}{NBW_{Ref}} \right] - (20 \text{ dB}) \log \left[2 - \frac{ChSpacing}{ChBW} \right] \right\}$$

Given this optimum attenuation, and a 10 dB step-size in the input attenuator, choose the input attenuator in the range:

$$\begin{aligned} ATTN &< ATTN_{opt} + 5.80 \text{ dB} \\ ATTN &> ATTN_{opt} - 4.20 \text{ dB} \end{aligned}$$

where:

$ATTN_{opt}$ is the optimum choice of attenuation.

$ATTN$ is the attenuator setting chosen within 10 dB increments.

$PdBTX$ is the transmitter power in units of dBm.

$DANL_{Ref}$ is the displayed average noise level specification for the analyzer, in dBm, with no input attenuation.

ML_{Ref} is the mixer level for which third-order distortion is specified in the spectrum analyzer.

$TODdB_{Ref}$ is the ratio of the signal power to the distortion component power for the third-order distortion specification, in dB, a positive number.

$ChBW$ and $ChSpacing$ are the channel bandwidth and channel spacing parameters
 NBW_{Ref} is the noise bandwidth for the resolution bandwidth in which $DANL$ is specified;
the NBW is 1.055 times the resolution bandwidth for RBW less than or equal to 100 Hz.

Adjacent Channel Power (ACP) Computations

The ACP ratios for the upper and lower adjacent channels are ratios of the power within these channels to the total transmitter power. The total transmitter power is computed as follows:

$$PWR Tx = (10 \text{ dB}) \log_{10} \left[\sum_{x1}^{x4} P(x) \frac{\left(\frac{SPAN}{600}\right)}{NBW} \right] + RL$$

where:

$x1$ and $x4$ are positions of the trace data points at the left edge of the lower adjacent channel and the right edge of the upper adjacent channel, respectively.

$P(x)$ is the power ratio of the indicated trace data at point x to the reference level. For example, if the trace data is -60 dB, $P(x)$ is 0.000001.

$SPAN/600$ is the spacing of trace data points.

NBW is the effective noise bandwidth of the resolution bandwidth used for the measurement. It depends on the shape of the resolution bandwidth filter, the scale, and the detector mode. For the ACP function, for most resolution bandwidths, the noise bandwidth is about:

$$1.128 \times 3 \text{ dB BW for } RBW \geq 300 \text{ Hz}$$

$$1.055 \times 3 \text{ dB BW for } RBW \leq 100 \text{ Hz}$$

RL is the reference level in dB units.

The power in the lower adjacent channel is given by the same expression, except that the upper summation limit is $x2$, the right edge of the lower channel, instead of $x4$. Likewise, the power in the upper channel includes summation limits from $x3$, the left edge of the upper channel, to $x4$.

The ACP leakage ratio displayed as **LOW** (lower channel) is given in decibels as the dB difference between the total power transmitted ($PWR Tx$) and the power in the lower channel. **UP** is computed similarly for the upper channel.

The edges of the adjacent channels, x1 through x4, are given by:

$$x1 = Fc - ChSp - (1/2 \times ChBW) + (0.307 \times RBW) + (1/2) \times (1/600) \times SPAN$$

$$x2 = Fc - ChSp + (1/2 \times ChBW) - (0.307 \times RBW) - (1/2) \times (1/600) \times SPAN$$

$$x3 = Fc + ChSp - (1/2 \times ChBW) + (0.307 \times RBW) + (1/2) \times (1/600) \times SPAN$$

$$x4 = Fc + ChSp + (1/2 \times ChBW) - (0.307 \times RBW) - (1/2) \times (1/600) \times SPAN$$

where:

Fc is the center frequency.

ChSp and ChBW are channel spacing and channel bandwidth.

RBW is the resolution bandwidth.

$1/2 \times 1/600 \times SPAN$ is one-half of the spacing of trace data.

$0.307 \times RBW$ is an effective passband shape for the power measurement that is -6 dB at the channel edges compared to the channel center. This correction to x1 through x4 will help the spectrum analyzer results agree with measuring receiver results, because a measuring receiver is specified to have a -6 dB response at the channel edges.

The ACP leakage ratio displayed as MAX ACP is that for either the lower or upper adjacent channel, whichever has the higher power. In other words, MAX ACP is the least negative of the dB numbers displayed as LOW and UP.

Single Sweep



SGL SWP sets the sweep and trigger to single-sweep mode and triggers one sweep. An **S** appears at the left edge of the display to indicate the active function status. To return to continuous-sweep mode, press **CONT** under either the **SWEEP** or **TRIG** key.

Marker Functions

This section describes the functions available from the MARKER section of the front panel.

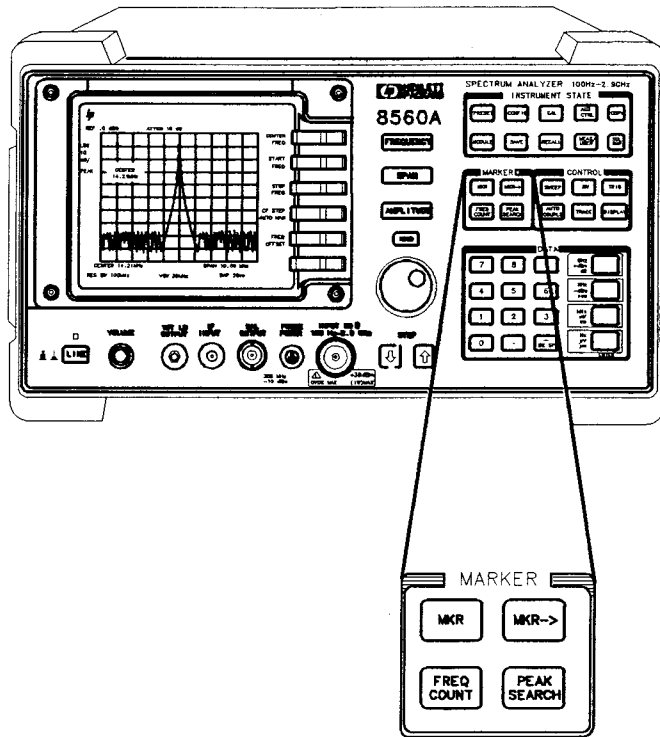

Marker Priority

Markers can be activated on trace A or trace B. However, the current state of the two traces determines on which trace the markers will appear. The trace states are listed below, in order of highest marker priority to lowest priority:

- Trace A in Clear-Write Mode
- Trace B in Clear-Write Mode
- Trace A in Max-Hold Mode
- Trace B in Max-Hold Mode
- Trace A in View Mode
- Trace B in View Mode

Marker

MKR

MARKER NORMAL
MARKER DELTA
MARKER 1/DELTA
MKRNOISE ON OFF
SIG TRK ON OFF
MARKERS OFF

MKR accesses a menu of softkeys, which are described below. **MKR** also activates the current marker mode (such as **MARKER DELTA**); if no mode is active, **MKR** activates **MARKER NORMAL**.

MARKER NORMAL

Activates a single marker and places it at the center of the trace. If one marker is already on, **MARKER NORMAL** becomes the active function. If two markers are on (as in marker-delta mode), **MARKER NORMAL** deletes the anchor marker and makes the active one the new, single marker. The marker reads the amplitude and the frequency (or the relative time, when the frequency span equals 0 Hz), and displays these values in the active function block and in the upper-right corner of the display. To move the marker, use either the knob, the step keys, or the data keys.

The marker reads data from the currently active trace, which is determined by the marker priority listed above (clear-write, max-hold, or view mode). If both traces are active, or if both traces are in view mode, the marker reads data from trace A.

MARKER DELTA

Reads the difference in amplitude and frequency (or time, when the frequency span equals 0 Hz) between two markers, and displays these values in the active function block and in the upper-right corner of the display. If a single marker is already on, **MARKER DELTA** places both an anchor marker and an active (movable) marker at the position of the original, single marker. To move the active marker, use either the knob, the step keys, or the data keys. If **MARKER 1/DELTA** has been activated and two markers are on, pressing **MARKER DELTA** once makes it the active function. However, if **MARKER DELTA** is already the active function, pressing **MARKER DELTA** again places the anchor marker at the same position as the active marker. The delta amplitude is displayed in dB, or as a ratio when linear units are selected. You can toggle between **MARKER DELTA** and **MARKER 1/DELTA** without changing the position of the markers.

**MARKER
1/DELTA**

Displays the reciprocal of the frequency or time difference between two markers in the active function block and in the upper-right corner of the display. If two markers are on and the frequency span is greater than 0 Hz, **MARKER 1/DELTA** displays the difference between the two markers in time. If two markers are on and the frequency span is equal to 0 Hz, **MARKER 1/DELTA** reads the difference in frequency. You can toggle between **MARKER 1/DELTA** and **MARKER DELTA** without changing the position of the markers.

**MKRNOISE
ON OFF**

Not available when a tracking generator is active.
Turns the marker noise function ON or OFF. When ON, this function normalizes the equivalent amplitude of the measured noise to a 1 Hz bandwidth. To do this, it sets the detector mode to sample and displays the average of 32 data points (16 data points on one side of the marker, the marker itself, and 15 data points on the other side). This average is corrected for effects of the log amplifier, bandwidth shape factor, RF detector, and resolution bandwidth. If two markers are on, **MKRNOISE ON OFF** works on the active marker and not on the anchor marker. When **MKRNOISE ON OFF** is ON, the sample detector mode is also initiated, which is the most appropriate detector mode for making noise measurements. Turning off the active marker also turns off **MKRNOISE ON OFF**, and returns the detector mode to its previous setting.

**SIG TRK
ON OFF**

Not available when a tracking generator is active.
Turns the signal-tracking function ON or OFF. The signal-track function keeps the active marker on the peak of the signal where it has been initially placed, and sets the center frequency to its value. This is done after every sweep, thus maintaining the marked signal at the center frequency. This allows you to “zoom in” quickly from a wide span to a narrow one without losing the signal from the screen. Or, use **SIG TRK ON OFF** to keep a slowly drifting signal centered on the display. When this function is active, a K appears on the left edge of the display.

**MARKERS
OFF**

Turns off all markers, blanks the softkey menu, and expands the display screen. This softkey turns off all marker-related functions such as **SIG TRK ON OFF** and **MKRNOISE ON OFF**, if they are on.

Marker ->

MKR->

Normal Marker
Span > 0 Hz

MARKER -> CF
MARKER -> REF LVL
MARKER -> CF STEP

Normal Marker
Zero Span

MARKER -> REF LVL

Delta Marker
Span > 0 Hz

MKR Δ -> CF
MKR Δ -> CF STEP
MKR Δ -> SPAN

Delta Marker
Zero Span

MKR $1/\Delta$ -> CF
MKR $1/\Delta$ -> CF STEP

MKR -> accesses a menu of marker functions that are described below. These marker functions allow the user to use the marker as a reference for changing analyzer settings.

The menu of marker functions that appear when **MKR ->** is pressed, depends on (1) the marker mode selected, either normal marker or delta marker, and (2) the frequency span. The softkey menus for these different modes are shown above.

Normal Marker Functions

MARKER->
CF

Sets the center frequency equal to the marker frequency. This function provides a quick way to move a signal to the center of the screen.

MARKER->
REF LVL

Sets the amplitude reference level equal to the amplitude of the marker.

MARKER->
CF STEP

Sets the center frequency step-size equal to the marker frequency.

Delta Marker Functions

MKR Δ ->
CF

Sets the center frequency of the spectrum analyzer equal to the delta frequency value. Once activated, both the anchor marker and the active marker are positioned at the new center frequency. This function is useful in harmonic distortion measurements, where the delta marker can be used to mark the difference between harmonics, and **MKR Δ -> CF** can be used to tune to the frequency of the fundamental.

MKR Δ ->
CF STEP

Sets the center-frequency step-size to the delta frequency value so that, when the center frequency function is active, using the step key will result in changes to the center frequency equivalent to the delta value. Stepping from one harmonic to another is useful in harmonic distortion measurements.

MKR Δ ->
SPAN

Sets the frequency span to the delta frequency value, allowing the user to span down quickly to the spectrum of interest.

MKR $1/\Delta$ ->
CF

Sets the center frequency equal to the reciprocal of the delta value. In zero span, the delta-marker frequency readout units are seconds. Therefore, the units for the reciprocal of the delta value will be in Hz.

MKR $1/\Delta$ ->
CF STEP

Sets the center-frequency step-size equal to the reciprocal of the delta value.

Frequency Counter

FREQ COUNT

COUNTER ON OFF
COUNTER RES
MARKER NORMAL
MARKER DELTA
PEAK SEARCH
NEXT PEAK

FREQ COUNT activates the frequency counter and displays its results in the upper-right corner of the screen. This replaces any current marker readout in that area. If **MARKER NORMAL** or **MARKER DELTA** is already active, **FREQ COUNT** uses that marker mode to read the frequency or the difference in frequency between two markers, respectively. If no marker mode is active, pressing **FREQ COUNT** automatically activates **MARKER NORMAL**. The counter will only count signals that are displayed on the screen. Thus, counter accuracy is lost when using **MARKER DELTA** when the anchor marker is off the screen. All signal-counting is done during the retrace time of the sweep. **FREQ COUNT** uses the same marker priority as described under "Marker Functions." **FREQ COUNT** cannot be used in zero span, on traces that are being viewed, in stimulus-response (tracking generator) measurements, in single-sweep mode, or in video trigger.

FREQ COUNT also accesses a menu of additional counter functions, which are described below.

COUNTER ON OFF

Activates (ON) or deactivates (OFF) the counter mode. This softkey is not available when a tracking generator is active. The counted value appears in the upper-right corner of the display.

COUNTER RES

Adjusts the resolution of the frequency-count measurement. The resolution ranges from 1 Hz to 1 MHz in decade increments. The default value is 10 kHz. The counter measurement occurs over a time interval of twice the reciprocal of the counter resolution for resolution bandwidths greater than or equal to 300 Hz.

MARKER NORMAL

Activates a single marker and places it at the center of the trace. If one marker is already on, **MARKER NORMAL** becomes the active function. If two markers are on (as in **MARKER DELTA** mode), **MARKER NORMAL** deletes the anchor marker and makes the active one the new, single marker. The marker reads the amplitude and the frequency, and displays these values in the active function block and in the upper-right corner of the display. To move the marker, use either the knob, the step keys, or the data keys.

**MARKER
DELTA**

Reads the difference in amplitude and frequency between two markers, and displays these values in the active function block and in the upper-right corner of the display. If a single marker is already on, **MARKER DELTA** places both an anchor marker and an active (movable) marker at the position of the original, single marker. To move the active marker, use either the knob, the step keys, or the data keys. If two markers are already on, pressing **MARKER DELTA** once makes it the active function. However, if **MARKER DELTA** is already the active function, pressing **MARKER DELTA** places the anchor marker at the same position as the active marker. The delta amplitude is displayed in dB, or as a ratio when linear units are selected.

**PEAK
SEARCH**

Places a marker on the highest point on a trace. The peak must meet the current peak excursion and peak threshold criteria in order to be considered a peak. The frequency and amplitude of the marker are displayed in the upper-right corner of the screen; **PEAK SEARCH** does not alter the active function.

**NEXT
PEAK**

Moves the active marker to the next-highest trace peak relative to the current marker position. This function finds successively lower peaks when the key is pressed repeatedly.

Peak Search

PEAK SEARCH

MARKER -> CF *
MARKER DELTA
NEXT PEAK
NEXT PK RIGHT
NEXT PK LEFT
MORE 1 OF 2 →

PEAK EXCURSN
PEAK THRESHLD

MORE 2 OF 2

* In zero span, this softkey becomes
MARKER NORMAL.

PEAK SEARCH places a marker on the highest point of a trace, makes the normal marker active, and accesses a menu of marker functions. The frequency and amplitude of the marker are displayed in the upper-right corner of the screen; **PEAK SEARCH** ignores the LO feedthrough as a peak. Peaks can be defined using **PEAK EXCURSN**. The functions available from the **PEAK SEARCH** menu are described below.

MARKER-> CF

Sets the center frequency equal to the marker frequency. This function provides a quick way to move a signal to the center of the screen. The active function is not affected. When the frequency span is equal to 0 Hz, this key accesses the **MARKER NORMAL** function.

MARKER DELTA

Reads the difference in amplitude and frequency (or time, when the frequency span equals 0 Hz) between two markers, and displays these values in the active function block and in the upper-right corner of the display. If a single marker is already on, **MARKER DELTA** places both an anchor marker and an active (movable) marker at the position of the original, single marker. To move the active marker, use either the knob, the step keys, or the data keys. If two markers are already on, pressing **MARKER DELTA** once makes it the active function. However, if **MARKER DELTA** is already on, pressing **MARKER DELTA** places the anchor marker at the same position as the active marker. The delta amplitude is displayed in dB, or as a voltage ratio when linear units are selected.

NEXT PEAK

Moves the active marker to the next-highest trace peak relative to the current marker position. The next peak must meet the current peak excursion and peak threshold criteria in order to be considered a peak. This function finds successively lower peaks when the key is pressed repeatedly.

NEXT PK RIGHT

Finds the next peak to the right of the current marker position. The next trace peak must meet the current peak excursion and peak threshold criteria in order to be considered a peak.

**NEXT PK
LEFT**

Finds the next peak to the left of the current marker position. The next trace peak must meet the current peak excursion and peak threshold criteria in order to be considered a peak.

**MORE
1 OF 2**

Accesses additional marker functions, which are described below.

**PEAK
EXCURSN**

Defines what constitutes a peak on a trace. To enter a value, use the data keys, step keys, or the knob and terminate the entry with **(dB)**. The value specifies the amount that a trace must increase monotonically and then decrease monotonically in order to be a peak. For example, if the peak excursion is 5 dB, the amplitude of the sides of a candidate peak must descend at least 5 dB in order to be considered a peak (see Figure 2-3). The excursion values range from 0 dB to 30 dB in log mode, and 0.1 Δ DIVS to 10.0 Δ DIVS in linear mode. The default value is 6 dB.

Any portion of a peak that falls below the peak threshold is also used to satisfy the peak excursion criteria. For example, when the peak excursion is equal to 6 dB, a peak that is equal to 3 dB above the peak threshold will be found if the peak extends an additional 3 dB or more below the threshold.

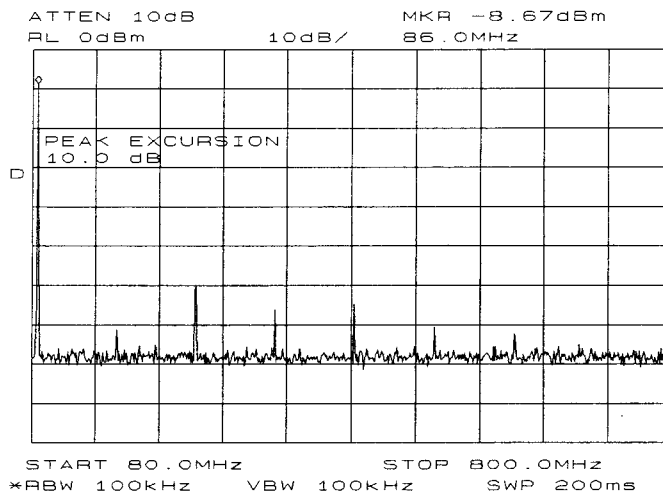

Figure 2-5. PEAK EXCURSN defines the peaks on a trace.

**PEAK
THRESHLD**

Sets the minimum amplitude level from which a peak on the trace can be detected. This function places a dashed line across the graticule to denote the selected level. To enter a value, use the data keys, the step keys, or the knob and terminate the entry with **+dBm** or **-dBm**. The default is -120 dBm.

Any portion of a peak that falls below the peak threshold is also used to satisfy the peak excursion criteria. For example, when the peak excursion is equal to 6 dB, a peak that is equal to 3 dB above the threshold will be found if the peak extends an additional 3 dB or more below the threshold.

**MORE
2 OF 2**

Displays the previous softkey menu.

Control Functions

This section describes the functions available from the CONTROL section of the front panel.

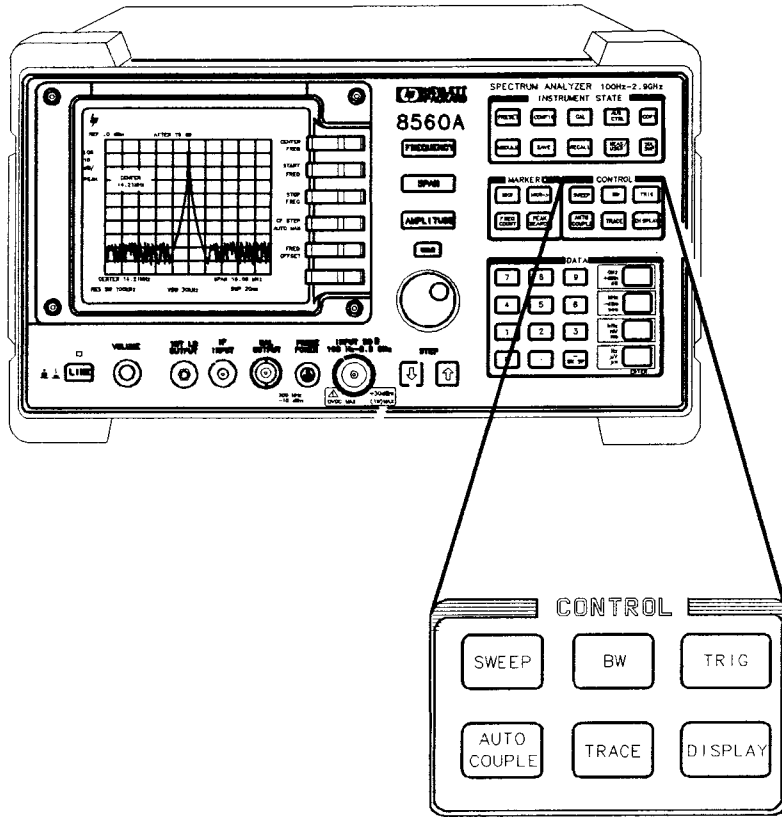

Sweep

SWEEP

SWP TIME AUTO MAN
CONT
SINGLE

SWEEP accesses a menu of sweep-related functions, which are described below. **SWEEP** also activates the sweep-time function.

SWP TIME AUTO MAN

Adjusts the sweep time of the spectrum analyzer. To change the sweep time, use the data keys, the step keys, or the knob. A line under AUTO or MAN indicates whether the sweep time can be manually set (MAN) or is coupled (AUTO), based on the resolution bandwidth, span, and video bandwidth settings. When the sweep time is in manual mode, press **SWP TIME AUTO MAN** until AUTO is underlined to return the sweep time to coupled mode.

When in stimulus-response, auto-coupled sweep-time mode (SR), which is usually much faster than spectrum-analyzer, auto-coupled sweep time mode (SA), an E appears in the special functions area at the left-hand side of the display screen. Manual sweep mode only applies to SA mode. If **SWP TIME AUTO MAN** is set to MAN, the analyzer sweep time defaults to SA mode. The **SWP CPL SR SA** softkey is located under the **TRACKING GENERATOR** menu under **AUX CTRL**.

CONT

Activates the continuous-sweep mode. This function, which is the default mode, is underlined to indicate that it is the current mode.

SINGLE

Activates the single-sweep mode. **SINGLE** is underlined, to indicate that it is the current sweep mode. Press **SINGLE** to restart the sweep at the next trigger. When this function is active, an S appears at the left edge of the display.

Bandwidth

BW

RES BW AUTO MAN
VIDEO BW AUTO MAN
VBW/RBW RATIO
RBW/SPAN RATIO
VID AVG ON OFF

BW accesses a menu of bandwidth functions, which are described below. **BW** also activates the resolution-bandwidth function.

RES BW AUTO MAN

Adjusts the resolution bandwidth. The bandwidth, which appears in the active function block, ranges from 10 Hz to 2 MHz in a 1, 3, 10 sequence. The value can be changed using the data keys, the step keys, or the knob. A line under AUTO or MAN indicates whether the bandwidth is coupled (AUTO) or is in manual mode (MAN). When the resolution bandwidth is in manual mode, press **RES BW AUTO MAN** until AUTO is underlined to return the bandwidth to coupled mode.

Note



10 Hz, 30 Hz, and 100 Hz resolution bandwidths are not available with external mixers.

VIDEO BW AUTO MAN

Adjusts the video bandwidth, which appears in the active function block, and ranges from 1 Hz to 3 MHz in a 1, 3, 10 sequence. The value can be changed using the data keys, the step keys, or the knob. A line under AUTO or MAN indicates whether the bandwidth is coupled (AUTO) or is in manual mode (MAN). When the video bandwidth is in manual mode, press **VIDEO BW AUTO MAN** until AUTO is underlined to return the bandwidth to coupled mode. When the video bandwidth is less than or equal to 100 Hz and the resolution bandwidth is greater than or equal to 300 Hz, the detector mode automatically changes to sample mode. When this function is active, a D appears in the special functions area at the left-hand side of the display screen.

Narrow video bandwidths help smooth a trace, allowing you to view signals that are otherwise masked by the noise. However, narrower bandwidths require longer sweep times, approximately proportional to the ratio of resolution bandwidth to video bandwidth.

VBW/RBW RATIO

Displays the current coupling ratio between the video bandwidth and the resolution bandwidth. The ratio is displayed in the active function block, and it is used when the two bandwidths are in coupled mode. The ratio ranges from 0.003 to 3, in a 1, 3, 10 sequence. The default value is 1.

**RBW/SPAN
RATIO**

Displays the current coupling ratio between the resolution bandwidth and the frequency span. The ratio is displayed in the active function block, and it is used when the two functions are in coupled mode. The ratio ranges from 0.002 to 0.10, in a 1, 2, 5 sequence. The default ratio is 0.011.

**VID AVG
ON OFF**

Turns the video averaging ON or OFF. Video averaging smooths the displayed trace without using a narrow video bandwidth. The function sets the detector mode to sample mode and smooths the trace by averaging successive traces with each other.

Trigger

TRIG

CONT
SINGLE
FREE RUN
VIDEO
LINE
EXTERNAL

TRIG accesses a menu of trigger functions, which are described below. When any mode other than **FREE RUN** is selected, a T appears in the special functions area at the left-hand side of the display screen.

CONT Activates the continuous-sweep mode. **CONT** is underlined, to indicate that it is the current sweep mode. In trigger modes other than free-run, press **CONT** to restart the sweep at the next trigger.

SINGLE Activates the single-sweep mode. **SINGLE** is underlined to indicate that it is the current mode. Press **SINGLE** to start a new sweep at the next trigger. An S appears at the left edge of the display to indicate the function's active status.

FREE RUN Sets the trigger to free-run mode. Sweep triggers occur as rapidly as the spectrum analyzer will allow.

VIDEO Sets the trigger to video mode. Sweep triggers occur whenever the input signal passes through, with a positive slope, the video trigger level. This trigger level can be changed using the data keys, the step keys, or the knob. A dashed line appears on the screen to denote the selected level. Note that in 1 dB/division, the error in this line can be up to three divisions.

LINE Sets the trigger to line mode. Sweep triggers occur at intervals synchronized to the line frequency.

EXTERNAL Sets the trigger to external mode. Connect an external trigger source to J5 EXT TRIG INPUT on the rear panel of the spectrum analyzer. The source must range from 0 to 5 V dc (TTL). The trigger occurs on the rising, positive edge of the signal (about 1.5 V).

Auto Couple

AUTO COUPLE

```
ALL
RES BW AUTO MAN
VIDEO BW AUTO MAN
SWP TIME AUTO MAN
ATTEN AUTO MAN*
MORE 1 OF 2 →
```

```
CF STEP AUTO MAN
UNITS AUTO MAN

MORE 2 OF 2
```

* Only available with internal mixing.

AUTO COUPLE accesses a menu of coupled-mode functions, which are described below.

ALL Sets the following functions to coupled mode: resolution bandwidth, video bandwidth, sweep time, input attenuator, center-frequency step-size, and units. The spectrum analyzer chooses appropriate values for these functions depending on the selected frequency and span (or start and stop frequencies). These values are set according to the coupled ratios stored under the softkeys **VBW/RBW RATIO** or **RBW/SPAN RATIO**. If no ratios are stored, default ratios are used instead.

**RES BW
AUTO MAN** Adjusts the resolution bandwidth. The bandwidth, which appears in the active function block, ranges from 10 Hz to 2 MHz in a 1, 3, 10 sequence. The value can be changed using the data keys, the step keys, or the knob. A line under AUTO or MAN indicates whether the bandwidth is coupled (AUTO) or is in manual mode (MAN). When the resolution bandwidth is in manual mode, press **RES BW AUTO MAN** until AUTO is underlined to return the bandwidth to coupled mode.

**VIDEO BW
AUTO MAN** Adjusts the video bandwidth, which appears in the active function block, and ranges from 1 Hz to 3 MHz in a 1, 3, 10 sequence. The value can be changed using the data keys, the step keys, or the knob. A line under AUTO or MAN indicates whether the bandwidth is coupled (AUTO) or is in manual mode (MAN). When the video bandwidth is in manual mode, press **VIDEO BW AUTO MAN** until AUTO is underlined to return the bandwidth to coupled mode. When the video bandwidth is less than or equal to 100 Hz and the resolution bandwidth is greater than or equal to 300 Hz, the detector mode automatically changes to sample mode.

**SWP TIME
AUTO MAN** Adjusts the sweep time of the spectrum analyzer. To change the sweep time, use the data keys, the step keys, or the knob. A line under AUTO or MAN indicates whether the sweep time is coupled (AUTO) or is in manual mode (MAN). When the sweep time is in manual mode, press **SWP TIME AUTO MAN** until AUTO is underlined to return the sweep time to coupled mode.

ATTEN
AUTO MAN

Available with internal mixing only.

Adjusts the spectrum analyzer input attenuator. The attenuator ranges from 0 dB to 70 dB in 10 dB increments. Input attenuation can be adjusted using the data keys, the step keys, or the knob; 0 dB attenuation can be selected using only the data keys. Attenuation is normally a coupled function and is automatically adjusted to changes in the reference level. The reference level, however, generally does not change when the attenuation changes. The attenuator is adjusted so that the maximum signal amplitude at the input mixer is -10 dBm or less. For example, if the reference level is 23 dBm, the attenuation is 40 dB, for an input of -17 dBm at the mixer (23 minus 40 equals -17). This prevents signal compression. Press either **ATTEN** or **ATTEN AUTO MAN** to adjust the input attenuator. A line under AUTO or MAN indicates whether the attenuator is coupled (AUTO) or in manual mode (MAN). When the input attenuator is in manual mode, press **ATTEN AUTO MAN** until AUTO is underlined to recouple the attenuator to the reference level.

MORE
1 OF 2

Accesses additional softkeys, which are described below.

CF STEP
AUTO MAN

Adjusts the center-frequency step-size. When this function is in coupled (AUTO) mode, pressing a STEP key yields a one-division shift (10 percent of span) in the center frequency. For manual (MAN) mode, press **CF STEP AUTO MAN** until MAN is activated. After entering a step size and changing the active function to **CENTER FREQ**, use the step keys to adjust the center frequency by the step size selected. The minimum settable step size is 25 Hz. This function is useful for quickly tuning to the harmonics of an input signal. For example, to tune to the harmonics of a 300 MHz signal, press **CF STEP** and enter 300 MHz. If the center frequency is at 300 MHz, pressing the step key increases the center frequency to 600 MHz, which is equal to the second harmonic. Pressing the STEP key again increases the center frequency by another 300 MHz, to 900 MHz. **CF STEP AUTO MAN** indicates whether the step size is in a coupled (AUTO) or manual mode (MAN). When the step size is in manual mode, press **CF STEP AUTO MAN** until AUTO is underlined to return the function to coupled mode.

UNITS
AUTO MAN

Allows amplitude units to be selected automatically (AUTO). This softkey is not available in normalized mode. When in AUTO mode, the default units are dBm (in log scale) or **VOLTS** (in linear scale).

In order to select amplitude units manually, the **AMPTD UNITS** softkey under **AMPLITUDE** must be selected. **UNITS AUTO MAN** appears, and selecting any of the available units executes the manual setting.

MORE
2 OF 2

Displays the previous menu of softkeys.

Trace

TRACE

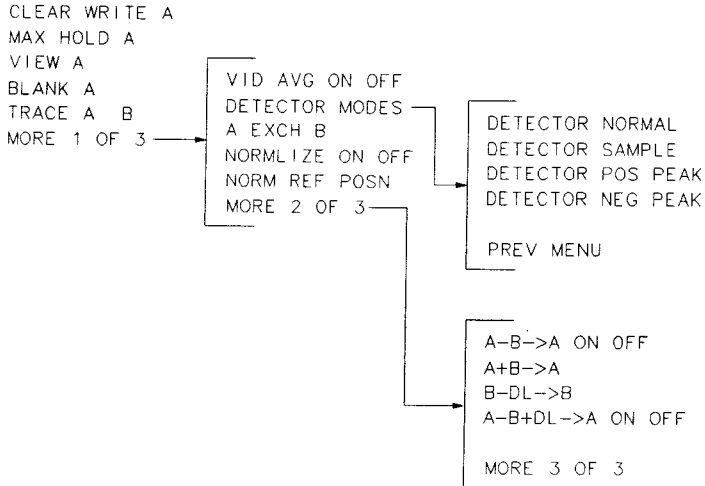

TRACE accesses a menu of trace-related functions, which are described below. Trace A is brighter than trace B, to distinguish between the two traces.

**CLEAR
WRITE A**

Clears trace A and sets it to accept and display new input-signal data continuously.

**MAX HOLD
A**

Displays and holds the maximum responses of the input signal in trace A. In this mode, the trace accepts data from subsequent sweeps and selects the positive-peak detector mode.

**VIEW
A**

Displays the current contents of trace A, but does not update the contents.

**BLANK
A**

Blanks trace A from the screen. The contents of trace A are retained, but not updated.

**TRACE
A B**

Toggles control of the above softkeys between traces A and B.

**MORE
1 OF 3**

Accesses additional trace function softkeys, which are described below.

VID AVG
ON OFF

Turns the video averaging ON or OFF. Video averaging smooths the displayed trace without using a narrow video bandwidth. The function sets the detector mode to sample mode and smooths the trace by averaging successive traces with each other.

Video averaging is available only for trace A, and trace A must be in clear-write mode for video average to be executed. After video averaging is activated, the number of sweeps that have been averaged appears at the top of the screen.

Using video averaging allows you to view changes to the entire trace much faster than using narrow video bandwidths. Narrow video bandwidths require long sweep times, which may not be desired. Video averaging, though requiring more sweeps, uses faster sweep times. Turning on video averaging allows the number of averages to be changed with the step keys, data keys, or knob, over the range of 1 to 999 readings.

DETECTOR
MODES

Accesses a menu of detector modes, which are described below. When any detector mode other than NORMAL is active, a D appears on the left edge of the display.

DETECTOR
NORMAL

Sets the detector to normal mode; this is also the default mode. In normal mode, the display simulates an analog display by alternately displaying positive and negative peaks when the presence of noise is detected, and displaying positive peaks otherwise.

DETECTOR
SAMPLE

Sets the detector to sample mode. This mode is used with the video averaging and marker noise functions, as well as for the combination of resolution bandwidths greater than or equal to 300 Hz and video bandwidths less than or equal to 100 Hz. Note that, when the resolution bandwidth is not much greater than the display resolution, the peak responses can be missed when the video signal is sampled.

DETECTOR
POS PEAK

Selects the positive-peak detector mode. Use this mode to detect the positive-peak noise level of a trace. This is the detector selected by **MAX HOLD**.

DETECTOR
NEG PEAK

Selects the negative-peak detector mode. Use this mode to detect the negative-peak noise level of a trace.

PREV
MENU

Displays the previous menu of softkeys.

A EXCH B

Exchanges the contents of trace A with those of trace B, and places both trace A and trace B in view mode.

NORMLIZE
ON OFF

Activates (ON) or deactivates (OFF) the normalization routine for stimulus-response measurements. The routine subtracts the calibration trace that is stored in trace B, from the active trace, trace A. The result is then offset by the normalized reference position. Results are displayed in trace A. The reference level value is displayed in dB when normalization is active.

When normalization is activated, an **N** appears in the special functions area at the left-hand side of the display screen. The **REF LVL** softkey under **AMPLITUDE** is replaced by **NORM REF LVL**.

Note

If a trace math function has been previously activated, turning normalize mode on deactivates the trace math function.

If a thru or open/short calibration state does not correspond to the current state when normalization is active, the error message **ERR #902 BAD NORM** appears.

**NORM REF
POSN**

Allows the user to adjust the normalized reference position that corresponds to the position on the graticule where the difference between the measured and calibrated traces reside. The normalized reference position may be adjusted between 0.0 and 10.0 using the data keys, step keys, or knob.

The normalized reference position adjustment allows measured data to be compared to a reference position, where the difference between the measured data and the reference position represents the gain or loss of the device under test.

When normalization is on, two indicators (**->** and **<-**) appear on-screen to mark the location of the normalized reference position.

**MORE
2 OF 3**

Accesses additional trace function softkeys, which are described below.

Note

Trace math functions are performed either in dBm units when in logarithmic mode, or in volts when in linear mode.

If normalize mode is active, performing a trace math function turns the normalize mode off.

**A-B->A
ON OFF**

Turns the trace math function **A-B->A** ON or OFF. When this function is ON, the contents of trace B are subtracted from the contents of trace A; the result is placed in trace A. When this function is on, it is executed on all subsequent sweeps. An **M** appears on the left edge of the display to indicate its active status.

A+B->A

Sums the contents of trace A with the contents of trace B, and places the result in trace A. This function is done only once and not on a continuous basis.

B-DL->B

Subtracts the value of the display line from the contents of trace B and places the result in trace B. This function is executed only once; to execute it a second time, press the softkey again. The display is activated as a result of this function.

**A-B+DL->A
ON OFF**

Turns the trace math function **A-B+DL->A** ON or OFF. When this function is ON, the contents of trace B are subtracted from the contents of trace A and the value of the display line is added to the result. The result is then displayed in trace A. This function is executed on all subsequent sweeps

until it is turned off. An **M** appears on the left edge of the display to indicate its active status.

The display line is activated as a result of this function; however, it can only be turned off by the **DSPL LIN ON OFF** softkey under **DISPLAY**.

MORE
3 OF 3

Displays the first page of the trace function softkey menus.

Display

DISPLAY

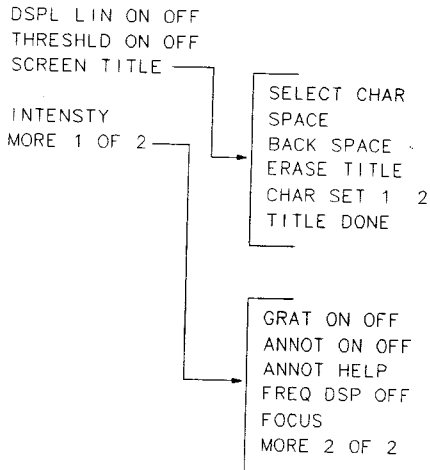

DISPLAY accesses a menu of display-related functions, which are described below.

**DSPL LIN
ON OFF**

Activates a display line that can be adjusted with the data keys, the step keys, or the knob. When the display line is ON, pressing **DSP LINE ON OFF** again turns the display line OFF.

**THRESHLD
ON OFF**

Sets a threshold that determines the lower limit of the active trace(s). To change the threshold, use the data keys, the step keys, or the knob. The selected level is indicated by a dashed line across the screen. When the trace is in max-hold mode, once the threshold is raised, any data below the new threshold is permanently lost.

**SCREEN
TITLE**

Displays a menu of functions that allow you to create a title on the screen. These functions are described below. **SCREEN TITLE** also displays a set of characters in the active function block. Use the step keys or the knob to select the desired characters for your title. After selecting the desired character, press **SELECT CHAR** to place it in the title area, which is in the upper-right corner of the graticule. The title can be up to two lines of 16 characters each.

**SELECT
CHAR**

Causes the currently selected character in the active function block to appear in the next available character position of the title, which is indicated by a “blinking” period. This key may be held down for repeated characters.

SPACE

Places a blank space in the next available character position in the title.

**BACK
SPACE**

Deletes the last character placed in the title.

**ERASE
TITLE**

Erases the current title from the display.

CHAR SET
1 2

Selects one of two character sets. Character set 1 contains uppercase letters, numbers, and miscellaneous characters. Character set 2 contains lowercase letters and miscellaneous characters.

TITLE
DONE

Fixes the current title and returns to the previous softkey menu.

INTENSTY

Changes the intensity of the display. Press **INTENSTY**, then use the data keys, the step keys, or the knob to adjust the intensity. The intensity ranges from 1 to 255; the current value appears in the active function block. When **INTENSTY** is pressed, **STORE INTEN** appears on the menu. Press **STORE INTEN** to store the new intensity value in nonvolatile memory.

For indoor use, keep the intensity around 80. For outdoor use, increase the intensity as necessary, keeping in mind that excessive brightness shortens the life of the CRT.

MORE
1 OF 2

Accesses a menu of additional softkeys, which are described below.

GRAT
ON OFF

Blanks the graticule from the display (OFF) or reactivates it (ON).

ANNOT
ON OFF

Blanks the annotation from the display (OFF) or reactivates it (ON).

ANNOT
HELP

Defines the annunciators that appear in the special functions area at the left-hand side of the display screen.

- A = IF adjust turned OFF
- C = DC coupling selected (ac coupling is default)
- D = Detector mode set to sample, negative peak, or positive peak
- E = Special sweep-time equations in use (refer to tracking generator menus)
- F = Frequency offset is less than or greater than 0 Hz
- G = Internal tracking generator is ON
- K = Signal track is ON
- M = Trace math is ON
- N = Normalization is ON
- R = Reference level offset is less than or greater than 0 dB
- S = Single-sweep mode
- T = Trigger mode set to line, video, or external
- X = 10 MHz reference is external
- + = External mixer bias is greater than 0 mA
- = External mixer bias is less than 0 mA

FREQ DSP
OFF

Turns off all frequency annotation. This includes the start and stop frequencies, center frequency, frequency span, marker readouts, center-frequency step-size, and signal identification to center frequency. Once this key is pressed, there is no way to display the frequency data. To reactivate the annotation, press **PRESET**.

FOCUS

Changes the focus of the display. Press **FOCUS**, then use the data keys, the step keys, or the knob to adjust the focus. The focus ranges from 0 to 255; the current value appears in the active function block. When **FOCUS** is pressed, **STORE FOCUS** appears on the menu. Press **STORE FOCUS** to store the new focus value. The overall display focus is only affected minimally.

MORE
2 OF 2

Displays the previous menu of softkeys.



Common Measurements

This chapter demonstrates analyzer measurement techniques with examples of typical applications; each application focuses on different features of the HP 8560A, HP 8561B, and HP 8563A spectrum analyzers. The measurement application and procedures covered in this chapter are listed below:

- Harmonic Distortion
- Third-Order Intermodulation Distortion
- AM and FM Demodulation
- Stimulus-Response Measurements
- External Millimeter Mixers
- Adjacent Channel Power Measurement

Example 1: Harmonic Distortion

What Is Harmonic Distortion?

Most transmitting devices and signal sources contain harmonics. Measuring the harmonic content of such sources is frequently required. In fact, measuring harmonic distortion is one of the most common uses of a spectrum analyzer. Harmonic distortion can be checked very quickly by using the measurement routine described below. This measurement routine measures harmonic amplitudes relative to the source frequency.

Spectrum Analyzer Functions Used

The harmonic distortion measurement below employs an important set of spectrum analyzer operating skills: setting the frequency span using start and stop frequencies; setting the video bandwidth and making relative measurements using two markers. It also demonstrates how to set a signal to center frequency using a marker and how to set the frequency step size to the value of the center frequency.

There are two common ways to measure harmonic distortion using a spectrum analyzer. The following procedure illustrates the faster method, which permits a simultaneous display of the fundamental and its harmonics. A second procedure is also given, and although it is somewhat lengthier to perform, it provides a better measurement of harmonics closer to the noise floor.

The example below measures the harmonic content of a 1 MHz signal provided by a signal generator. If desired, you may use the 300 MHz calibrator signal of the spectrum analyzer.

However, be sure to adjust the spectrum analyzer start and stop frequencies to accommodate the source frequency and its harmonics.

Stepping through the Fast Harmonic Measurements

Connect the signal source to the spectrum analyzer INPUT 50Ω and complete the following steps. Start from a preset state by pressing **PRESET**.

1. For measuring the 1 MHz fundamental and its first two harmonics, set the start frequency to 450 kHz and the stop frequency to 3.5 MHz. This displays the fundamental frequency and the second and third harmonics as shown in Figure 3-1. To improve visibility, smooth the noise by pressing **BW** and then **VIDEO BW AUTO MAN** until **MAN** is selected. Now use the step down **▼** key as desired.

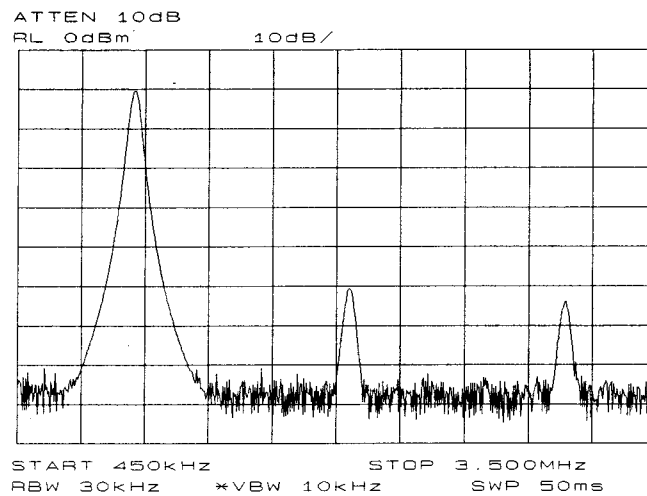

Figure 3-1. Input Signal and Harmonics

2. For greatest measurement accuracy, raise the peak of the fundamental to the reference level by pressing **PEAK SEARCH**, **MKR ->**, and then **MARKER -> REF LVL**. This is shown in Figure 3-2. In order to place a second marker on the second harmonic, set the peak threshold above the noise by pressing **PEAK SEARCH**, **MORE 1 OF 2**, and **PEAK THRESHLD**. Adjust the dashed line to a level above the noise using either the step keys or the knob. To activate a second marker, press **PEAK SEARCH**, **MARKER DELTA**, and **NEXT PK RIGHT**. This places the anchor marker on the fundamental, and a second marker on the peak of the second harmonic as shown in Figure 3-3. The difference in amplitude between the fundamental and second harmonic shown in the figure is approximately -50 dB, or 0.33 percent harmonic distortion (see Figure 3-4). To measure the third harmonic, press **NEXT PK RIGHT** again. Continue reading amplitudes and comparing them to Figure 3-4 for each additional harmonic you wish to measure. **PEAK EXCURSN** defines what is and is not a peak; the next-peak routines find the corresponding peak.

Another easy way of determining the percent of distortion is to change the units to volts. Press **AMPLITUDE**, **MORE 1 OF 3**, **AMPTD UNITS**, and then **VOLTS**. The marker readout automatically switches to voltage units. To determine the percentage of distortion, use the ratio given by the marker and move the decimal point of this value two places to the right.

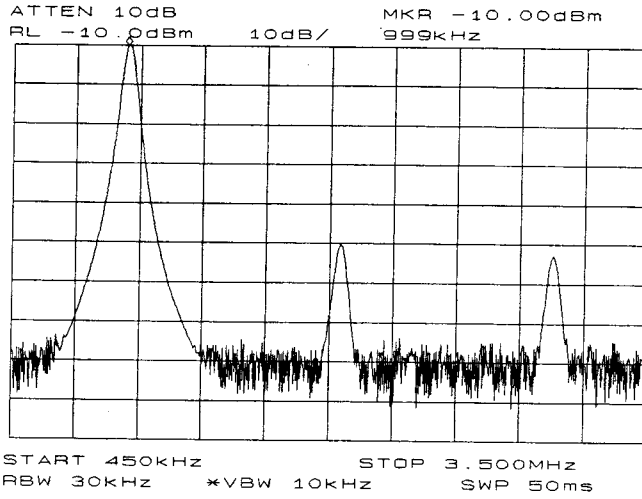

Figure 3-2. Peak of signal is positioned at reference level for maximum accuracy.

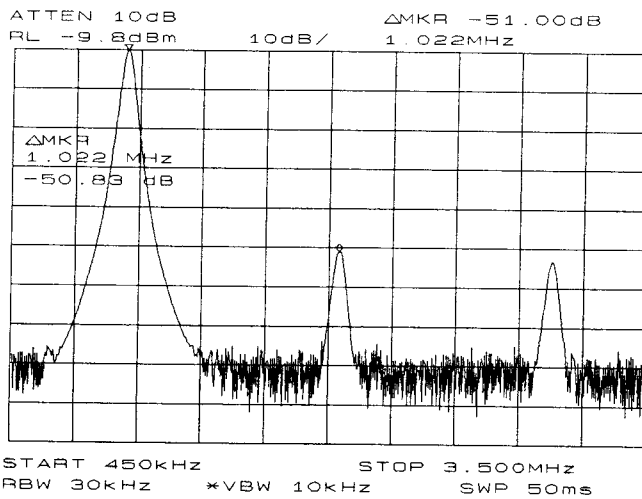

Figure 3-3. Harmonic distortion measured in dBc. Marker threshold set to -70 dB.

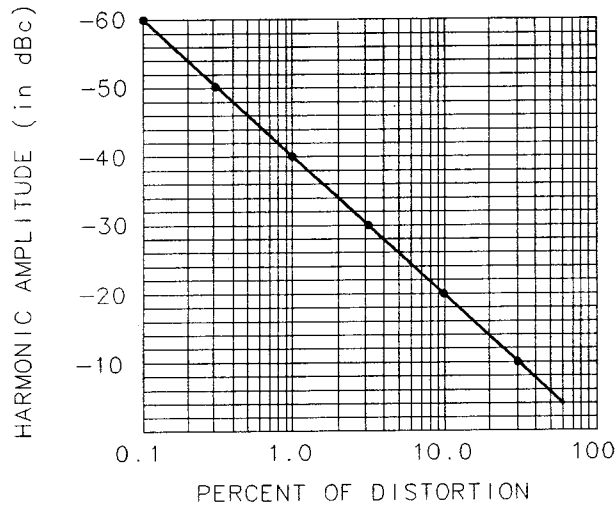

Figure 3-4. Percentage of Distortion versus Harmonic Amplitude

- You may want to plot the display for hard-copy documentation. To do this, simply connect a graphics plotter (such as an HP 7440A Color Pro) to the analyzer via HP-IB. Set the plotter address to 5. On the spectrum analyzer, press **CONFIG** and then **COPY DEV PRNT PLT** until PLT is selected. Press **PLOTTER CONFIG** to view available plot functions. Then, press **COPY** to transfer the entire display contents to the plotter. Other plotter functions allow you to select certain traces or parts of the display for plotting. The **PLOT ORG DSP GRAT** function lets you choose the plotter reference points to correlate to the display (DSP) or to the display graticule (GRAT).

Alternative Measurement Method

This method is somewhat lengthier, but because each signal is measured in a narrower span and resolution bandwidth, the signal-to-noise ratio is improved, making the results more accurate.

- Using the present setup, clear the markers from the screen by pressing **MKR**, then **MARKERS OFF**. Notice that when **MARKERS OFF** or **HOLD** is pressed, the display expands to the full size of the screen, for easier viewing. To measure the fundamental, press **PEAK SEARCH**, which activates a marker on the highest-level signal on-screen. Reduce the frequency span to 1 MHz by pressing **SPAN**, then **SPAN ZOOM** and entering 1 MHz. The span zoom function allows you to quickly “zoom” to a narrower frequency span without losing the signal from the screen (since signal track is activated). After the frequency span is reduced, turn off the signal-track function by pressing **MKR**, and setting **SIG TRK ON OFF** to OFF. Next, set the center-frequency step-size to the frequency of the fundamental by pressing **MKR ->**, then **MARKER -> CF STEP**. For better amplitude accuracy, move the signal to the top of the graticule by pressing **MARKER -> REF LVL**. The resulting display should resemble Figure 3-5.

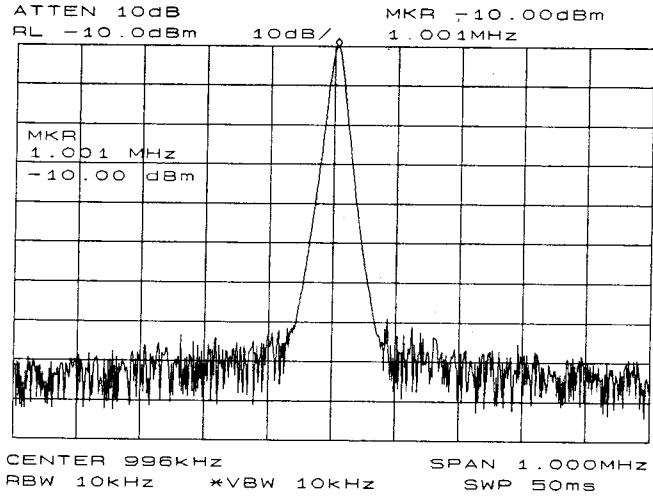

Figure 3-5. Input Signal Displayed in a 1 MHz Span

- To measure the second harmonic, press **MKR**, **MARKER DELTA**, **FREQUENCY**, and the step up **▲** key. This step retunes the spectrum analyzer center frequency to the second harmonic. Adjust the harmonic to the reference level. (Note that the **MARKER -> REF LVL** function is not available in marker-delta mode.) This displays the amplitude of the second harmonic as shown in Figure 3-6. The difference between the second harmonic and the fundamental can be converted to a percentage of distortion using Figure 3-4. Again, units can be changed to volts in order to read the voltage ratio of the two signals.

For each additional harmonic you wish to measure, simply press the step up **▲** key and adjust the reference level. Note the arrow in the upper left corner of the graticule indicates that the anchor marker is off-screen. However, the results are still valid.

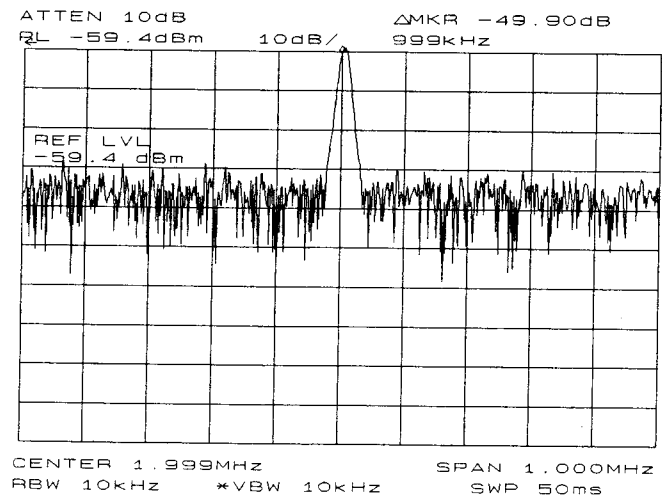

Figure 3-6. Second Harmonic Displayed in dBc

Percent of Harmonic Distortion

Measuring the total percent of harmonic distortion of a signal is also performed frequently. For this measurement, the amplitude of each harmonic must be measured in linear units (for example, volts) instead of dBc. (To display amplitude units in volts, press **AMPLITUDE** and the softkeys **MORE 1 OF 3**, **AMPTD UNITS**, and **VOLTS**). The amplitude values of these signals are used in the equation below to compute total harmonic distortion.

$$\text{Percent of distortion} = \frac{\sqrt{(A_2)^2 + (A_3)^2 + (A_4)^2 \dots + (A_n)^2}}{A_1} \times 100$$

Where:

- A_1 = the amplitude of the fundamental frequency, in volts
- A_2 = the amplitude of the second harmonic, in volts
- A_3 = the amplitude of the third harmonic, in volts
- A_4 = the amplitude of the fourth harmonic, in volts
- A_n = the amplitude of the n harmonic, in volts

If the signal amplitudes are measured carefully, as in the previous example, this procedure measures percent-of-harmonic distortion very accurately.

Example 2: Third-Order Intermodulation Distortion

What Is Intermodulation Distortion?

In crowded communication systems, signal interference of one device with another is a common problem. For example, two-tone, third-order intermodulation is often a problem in narrow-band systems. When two signals (F_1 and F_2) are present in a system, they can mix with the second-order harmonics that are generated ($2F_1$ and $2F_2$) to create third-order intermodulation distortion products, which are located close to the original signals at $2F_2 - F_1$ and $2F_1 - F_2$. Higher order intermodulation distortion can also occur. These distortion products are generated by such system components as amplifiers and mixers.

Spectrum Analyzer Functions Used

The procedure below describes how to measure third-order intermodulation distortion. It shows how to tune two signals onto the spectrum analyzer display and demonstrates setting the resolution bandwidth, mixer level, and reference level. It also incorporates several marker functions.

Stepping through the Measurement

To test a device for third-order intermodulation, connect the equipment as shown in Figure 3-7. This example uses two sources set to 20 MHz and 21 MHz. Other source frequencies may be substituted, but maintain a frequency separation of approximately 1 MHz to best follow this example. In this example, a 6 dB directional coupler is used. The device under test is a 26 dB preamplifier. The low-pass filters are not required if this procedure is used only to practice using the instrument.

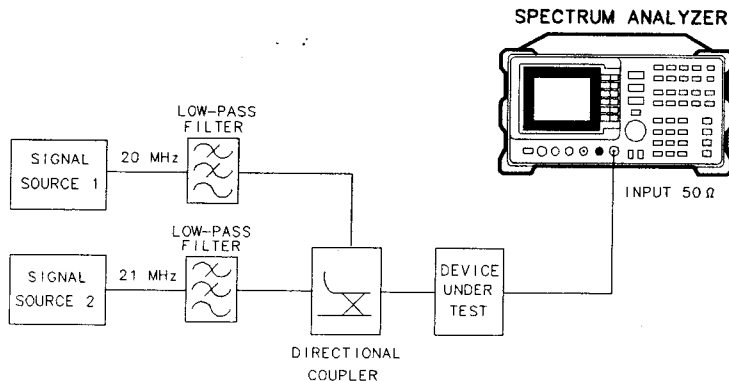

Figure 3-7. Third-Order Intermodulation Test Setup

1. Set one source to 20 MHz and the other source to 21 MHz for a frequency separation of 1 MHz. Set the sources equal in amplitude (for this example, we have set the sources to -30 dBm).

2. Tune both signals onto the display by setting the center frequency to 20.5 MHz. Next, reduce the frequency span to 5 MHz for a span wide enough to include the distortion products on the display. For frequency separations other than the ones used in this example, choose a span greater than three times the separation of the source signals.

A quick way to get to a smaller frequency span is to use **SPAN ZOOM**. **SPAN ZOOM** activates a highest-peak marker, turns signal track on, and zooms down to the span selected by the user. To activate the span zoom function, press **(SPAN)**, **SPAN ZOOM**, and enter 5 MHz. Do not forget to turn signal track off before changing other spectrum analyzer settings.

Press **(FREQUENCY)** and, using the knob, center the two signals on the displays, as shown in Figure 3-8. If necessary, to be sure that the distortion products are resolved, reduce the resolution bandwidth until the distortion products are visible; press **(BW)**, then use the step down **(▼)** key to reduce the resolution bandwidth. You may wish to reduce the video bandwidth as well. To ensure that the input signals are equal in amplitude, press **(PEAK SEARCH)**, **MARKER DELTA**, and **NEXT PEAK**. Adjust the signal source with the corresponding marker on it until the difference in amplitude reads zero.

Note



It is sometimes necessary to choose a specific resolution bandwidth to verify that the distortion products are at a certain level below the source signal. For these cases, refer to Appendix G.

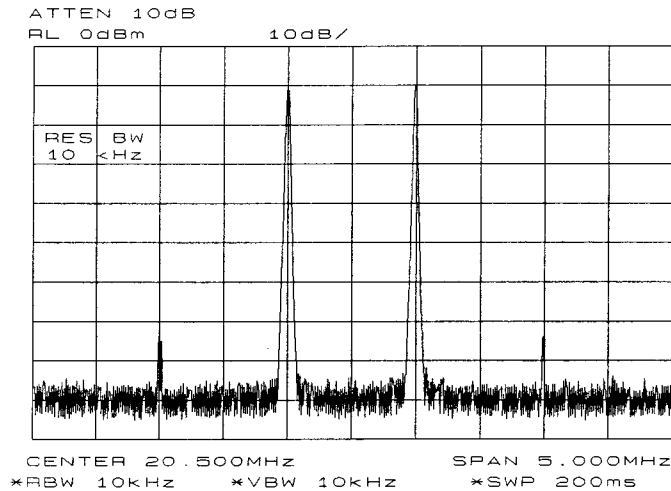

Figure 3-8. Signals Centered on Spectrum Analyzer Display

- For greatest measurement accuracy, position the peaks of the source signals at the reference level. The spectrum analyzer function **MARKER -> REF LVL** allows you to set the reference level using a marker. First, place a marker on the source signal of highest amplitude by pressing **PEAK SEARCH**. Then set the reference level to this value by pressing **MKR ->**, and then **MARKER -> REF LVL**. Figure 3-9 illustrates the resulting display.

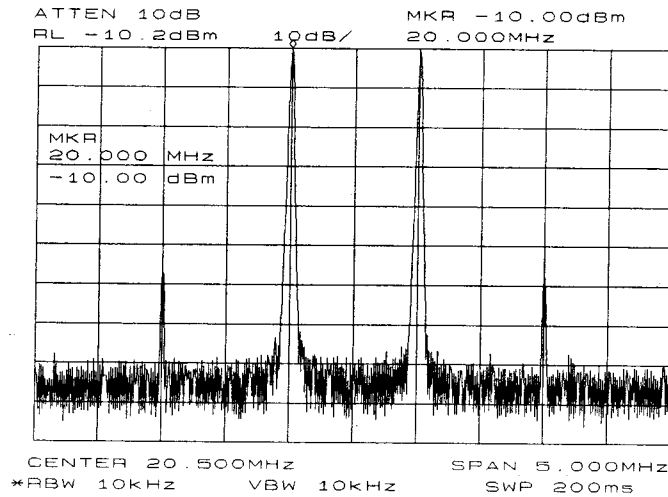

Figure 3-9. Signal Peak Set to Reference Level

- For this type of measurement, distortion-free dynamic range is an important consideration. To maximize such dynamic range, set the mixer input level to -30 dBm by pressing **AMPLITUDE**, **MORE 1 OF 3**, **MAX MXR LEVEL**, and enter -30 dBm. The spectrum analyzer automatically sets the attenuation so that the maximum signal level is -30 dBm at the input mixer when the signal is at or below the reference level (see Appendix G). You will hear the input attenuator click; notice that the value of the attenuator is now 20 dB (see Figure 3-10).

This change to the maximum mixer level may affect the noise, so adjustments to the resolution and video bandwidths may be required.

- Once a marker is activated, the marker-delta function activates a second marker and displays the difference between the two markers. Relative measurements can then be performed easily. To measure a distortion product, press **PEAK SEARCH** to place a marker on a source signal. To activate a second marker, press **MARKER DELTA** and **NEXT PK LEFT** or **NEXT PK RIGHT** to set the second marker on the peak of the distortion product that is beside the signal source, as in Figure 3-10. The difference in frequency and amplitude between the two markers is displayed in the active function block.

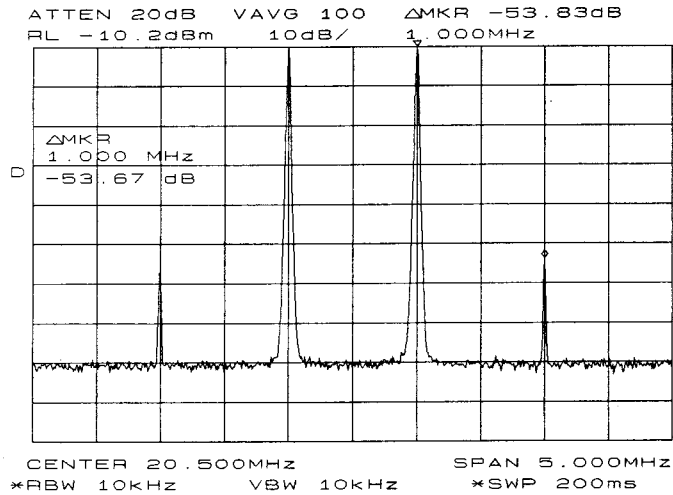

Figure 3-10. Intermodulation Distortion Measured in dBc

6. You may want to store the measurement information for future use. The save and recall functions allow you to store data for later viewing. The screen title function allows you to create a title on the screen and a label for the recall menu. To create a title, press **DISPLAY** and then **SCREEN TITLE**. Next, use the softkeys from the screen-title menu and the knob (to choose the letters) to create a title. The title appears in the upper-right corner of the graticule and can be up to two rows of 16 characters each (see Figure 3-11). Press the softkey **TITLE DONE** when the title is complete.

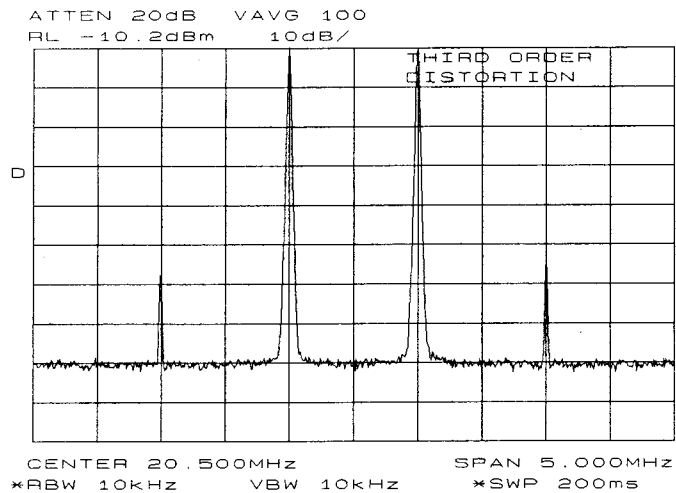

Figure 3-11. Display with Title

7. To save the instrument state, press **SAVE**, then **SAVE STATE**. Then press a softkey to enter the instrument state data into whichever register (0-9) you select. The first sixteen characters of the title are used to label the register on the recall menu. To view this menu, press **RECALL** and then **RECALL STATE**. If a stored state has not been titled, the menu reads **STATE** followed by the register number chosen.

Example 3: AM and FM Demodulation

Introduction

Amplitude modulation (AM) and frequency modulation (FM) are two very common types of modulation techniques used to transmit information. AM and FM signals are used in broadcasting information via the airwaves. In the United States and Canada, the AM broadcast band is 535 kHz to 1605 kHz, while the FM broadcast band covers 88 MHz to 108 MHz.

Demodulation of AM and FM signals can be done with any spectrum analyzer with zero span capability and with a wide enough bandwidth to fully encompass the modulated signal. An easier method for examining a demodulated signal is to use the built-in AM/FM demodulator and speaker in the HP 8560A, HP 8561B, and HP 8563A Spectrum Analyzers. For simplicity in our example, we will just demodulate an FM signal. To demodulate and listen to an AM signal, repeat the same steps, except activate **AM DEMOD ON OFF** instead of **FM DEMOD ON OFF**.

Spectrum Analyzer Functions Used

The procedure below illustrates the use of the HP 8560A, HP 8561B, and HP 8563A's built-in AM and FM demodulator and speaker. The example includes tuning the spectrum analyzer to a band of interest, activating and moving a marker to the signal that is to be demodulated, and demodulating and listening to the signal with the built-in demodulator and speaker.

Stepping through the Measurement

Provide a signal to the spectrum analyzer by connecting an antenna to the input port of the spectrum analyzer.

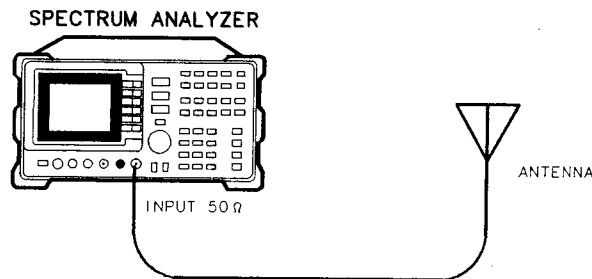

Figure 3-12. AM and FM Demodulation Test Setup

1. Tune to the FM band by setting the start frequency of the spectrum analyzer to 88 MHz, and the stop frequency to 108 MHz. Press **FREQUENCY**, **START FREQ**, enter 88 MHz, **STOP FREQ**, and enter 108 MHz (see Figure 3-13).

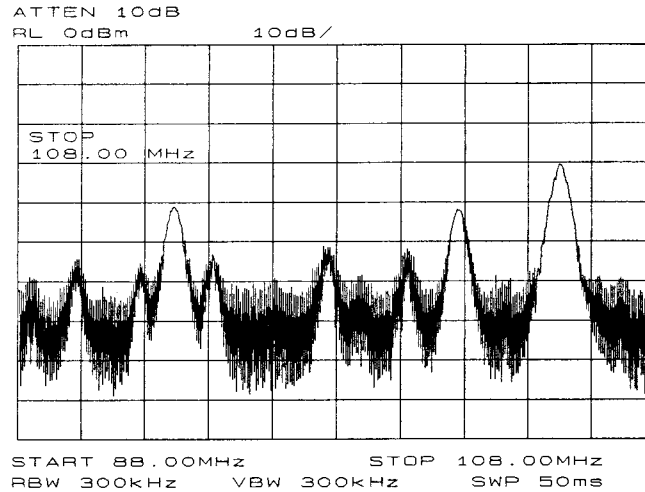

Figure 3-13. FM Band

- To demodulate an FM signal, a marker must be activated before the demodulator is turned on. For easier use, the AM/FM demodulation menu contains the marker functions. Pressing **AUX CTRL**, then **AM/FM DEMOD** will show the demodulation menu. Activate a marker by pressing **MARKER NORMAL**. Position the marker on the signal of interest. If the signal of interest is the highest in amplitude, press **PEAK SEARCH** directly, as in Figure 3-14.

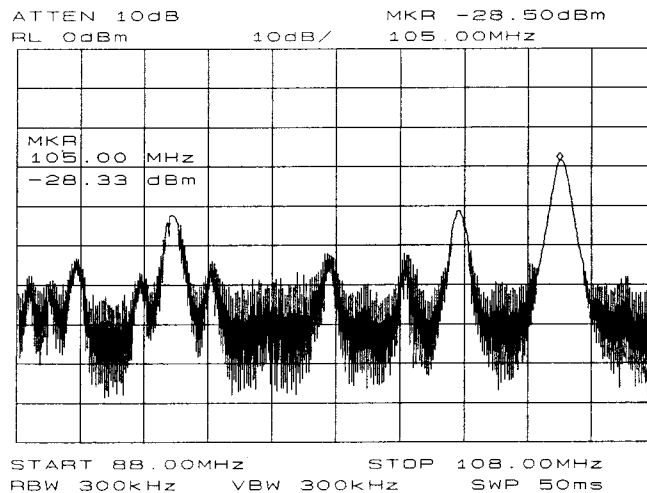

Figure 3-14. Place a marker on the signal of interest, then demodulate.

- For this example, before demodulating the signal, set the demodulation time to 30 seconds by pressing **MORE 1 OF 2**, **DEMOD TIME**, and entering 30 seconds. This sets the actual time that the built-in demodulator will demodulate the signals in order for you to listen to it. Now, set **FM DEMOD ON OFF** to ON. You may have to adjust the volume of the speaker using the volume knob located on the front panel, under the display.

Example 4: Stimulus-Response Measurements

What Are Stimulus-Response Measurements?

Stimulus-response measurements require a source to stimulate a device-under-test (DUT) and a receiver to analyze the frequency-response characteristics of the DUT. Characterization of a DUT can be made in terms of its transmission or reflection parameters. Examples of transmission measurements include ripple, flatness, and rejection. A typical reflection measurement is return loss.

A spectrum analyzer combined with a tracking generator forms a stimulus-response measurement system. With the tracking generator as the swept source and the spectrum analyzer as the receiver, operation is analogous to a single-channel scalar network analyzer. Being a narrow-band system, the tracking generator's output frequency must be made to precisely track the spectrum analyzer's input frequency, resulting in a wide dynamic range. This wide dynamic range will be illustrated in the following example. Figure 3-15 shows the block diagram of a spectrum analyzer/tracking generator system.

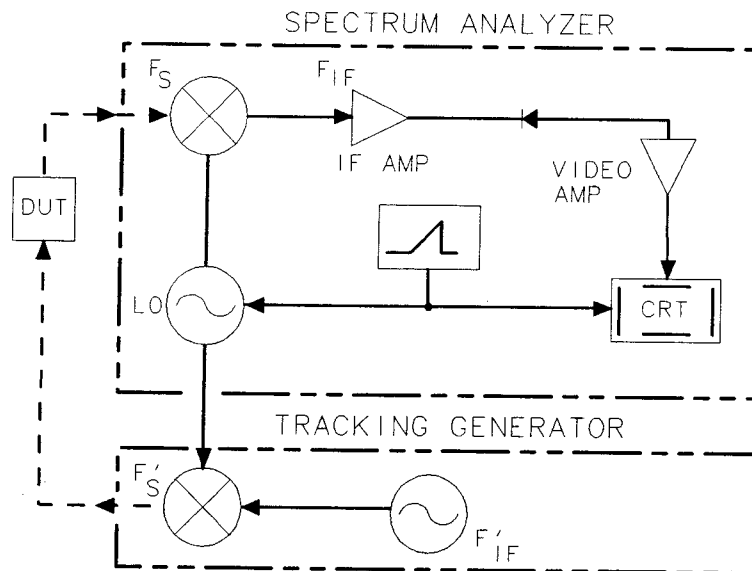

Figure 3-15.
Block Diagram of a Spectrum Analyzer/Tracking Generator Measurement System

Spectrum Analyzer Functions Used

The procedure below describes how to use the HP 8560A Option 002 Spectrum Analyzer with built-in tracking generator system to measure the rejection range of a bandpass filter, which is a type of transmission measurement. The same measurement can be made using an HP 8561B Spectrum Analyzer with an HP 85640A Tracking Generator. Illustrated in this example are the functions in the tracking-generator menu, such as adjusting the tracking-generator output power, source calibration, and normalization. Conducting a reflection measurement is similar and will not be covered. Refer to the HP Spectrum Analyzer Seminar, or Application Note 150-7, for more information.

Stepping through the Measurement

There are four basic steps in performing a stimulus-response measurement, whether it be a transmission or reflection measurement: set-up the spectrum analyzer settings, calibrate, normalize, and measure.

To measure the rejection of a bandpass filter, connect the equipment as shown in Figure 3-16. This example uses a bandpass filter with a center frequency of 321.4 MHz and a specified rejection of -85 dB, as the device under test (DUT).

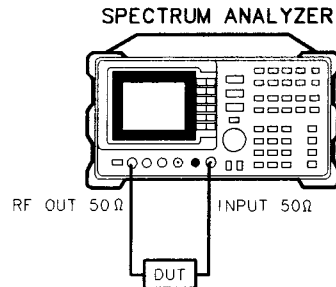

Figure 3-16. Transmission Measurement Test Setup

1. Activate the tracking generator menu by pressing **AUX CTRL**, then **TRACKING GENERATOR**. The tracking-generator output power is then displayed in the active function block. Since the filter (DUT) is not particularly sensitive, an output power of -10 dBm should not damage it. To activate the tracking-generator power level, press **SRC PWR ON OFF** until ON is selected.

Note if the error ERR 901 TGF r qLmt appears in the error message area. If this occurs, set the start frequency to 300 kHz. (Stimulus-response measurements using an HP 8560A Option 002 and an HP 85640A are specified from 300 kHz to 2.9 GHz.) Due to the current resolution of the annotation, changing the start frequency to 300 kHz will only be denoted in smaller spans.

2. Put the sweep-time of the analyzer into stimulus-response auto-coupled mode by pressing **MORE 1 OF 3**, then **SWP CPL SR SA** until SR is selected. In stimulus-response mode, the auto-coupled sweep times are usually much faster for swept-response measurements (see Figure 3-17).

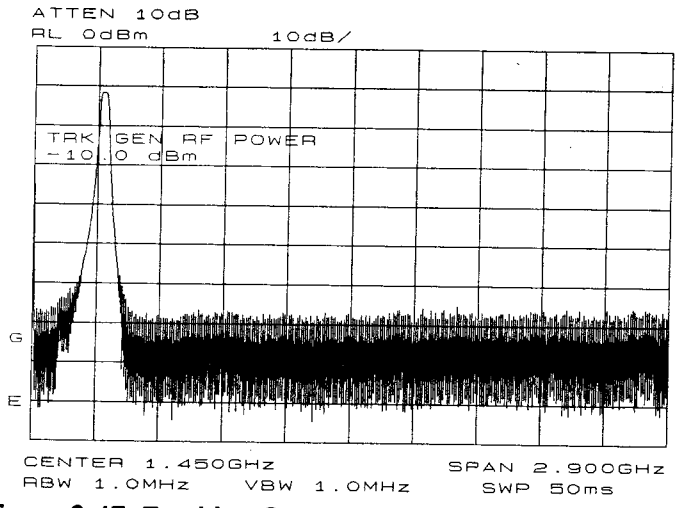

Figure 3-17. Tracking-Generator Output Power Activated

3. Since we are only interested in the rejection of the bandpass filter, tune the spectrum analyzer's center frequency so that the rolloff of the filter comprises the majority of the trace on the display (see Figure 3-18).

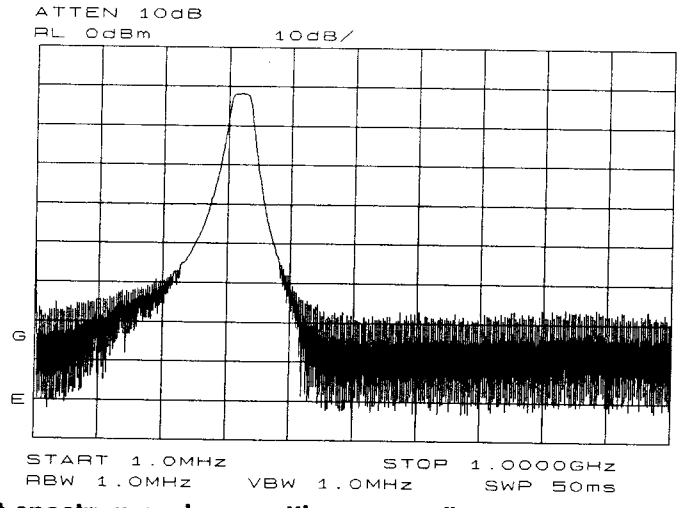

Figure 3-18. Adjust spectrum analyzer settings according to the measurement requirement.

4. Decrease the resolution bandwidth to increase sensitivity, and narrow the video bandwidth to smooth the noise. In Figure 3-19, the resolution bandwidth has been decreased to 3 kHz.

Note

The minimum resolution bandwidth supported in stimulus-response measurements is 300 Hz.

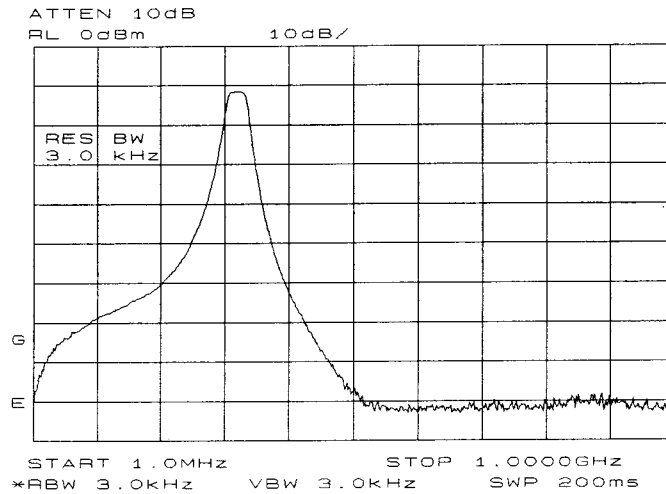

Figure 3-19. Decrease the resolution bandwidth to improve sensitivity.

Note that adjusting the resolution bandwidth may result in a decrease in amplitude of the signal. This is known as a tracking error. Tracking errors occur when the tracking generator's output frequency is not exactly matched to the input frequency of the spectrum analyzer. The resulting mixing product from the spectrum analyzer's input mixer is not at the center of the IF bandwidth. Tracking errors are most notable when using narrow resolution bandwidths. Compensate for the tracking error, by using either the manual or automatic tracking adjustment. These keys can be found on the second softkey menu page of **TRACKING GENERATOR** under the **(AUX CTRL)** key.

Note that once the automatic tracking routine is activated in a wide resolution bandwidth, it is not necessary to use the tracking adjust again when decreasing the resolution bandwidth. The automatic tracking routine uses the 300 Hz resolution bandwidth to perform the tracking adjustment. To activate the automatic tracking routine, press **TRACKING PEAK**, then press **MAN TRK ADJ** to display the DAC values of the coarse and fine-tracking adjustments. In this example, the automatic tracking routine was performed, and the resolution bandwidth was decreased to 300 Hz, without encountering any tracking error (see Figure 3-20).

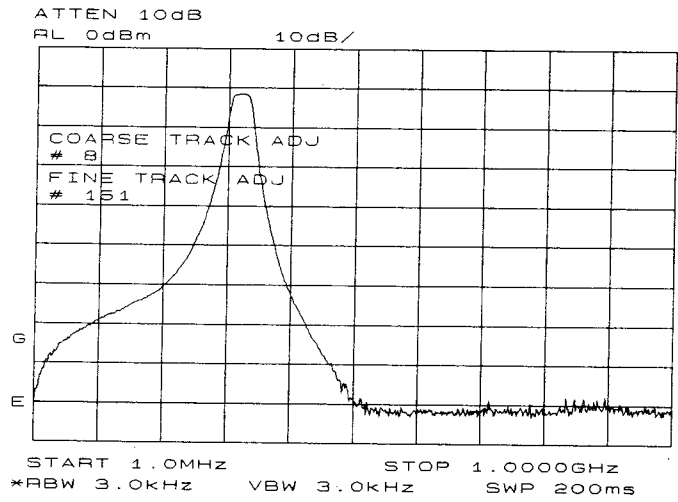

Figure 3-20. Manual tracking adjustment compensates for tracking error.

5. Calibration in a transmission measurement is done using a through (thru). To calibrate using a thru, press **AUX CTRL**, **TRACKING GENERATOR**, **SOURCE CAL MENU**, **CAL THRU**. The guided calibration routine prompts you to connect the thru, as illustrated in Figure 3-21. Connect the thru, and press **STORE THRU** when ready. When **STORE THRU** is pushed, the thru trace is stored into trace B and into an internal memory location in the analyzer. The state information of the thru-calibration trace is stored in state register #9. This trace can be recalled for future use. Figure 3-22 shows what appears on-screen after the thru trace is stored. Trace B is in view, depicting the thru trace.

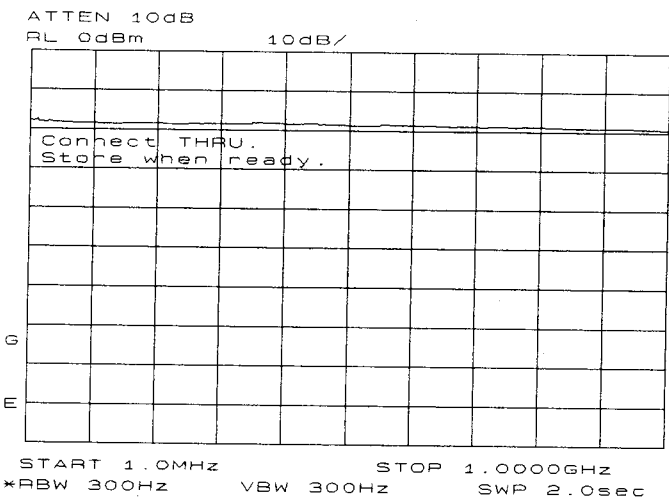

Figure 3-21. Guided calibration routines prompt the user.

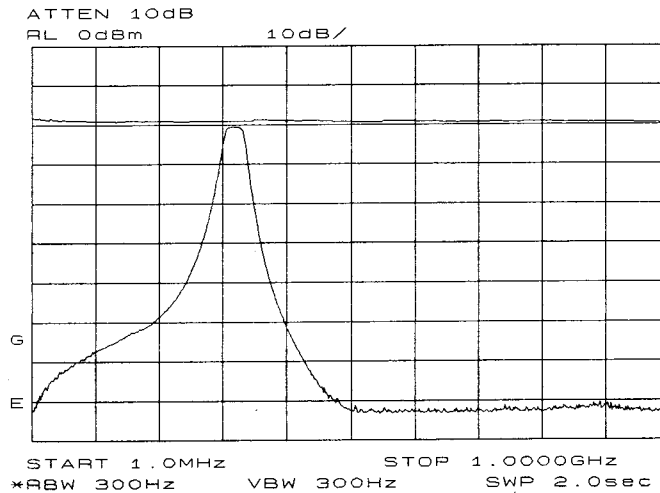

Figure 3-22. The thru trace is displayed in trace B.

6. Normalization eliminates the frequency response error in the test-setup. When normalization is on, trace math is being performed on the active trace ($A - B + NRP \rightarrow A$), where A is the active trace, B is the stored thru calibration trace, and NRP is the normalized reference position. Note that the units of the reference level, dB, reflect this relative measurement (see Figure 3-23).

To normalize, press **NORMLIZE ON OFF** until ON is selected. (This softkey is located on the first page of the tracking-generator menu.) Note that two arrows appear on each side of the graticule, when normalization is activated. These two arrows mark the normalized reference position, or the position where 0 dB insertion loss (transmission measurements) or 0 dB return loss (reflection measurements) will normally reside. The dB value of the normalized reference position can be set using the **NORM REF LVL** adjustment under the **AMPLITUDE** key. Changing **NORM REF POSN** will result in a change in the position of the normalized trace, within the range of the graticule.

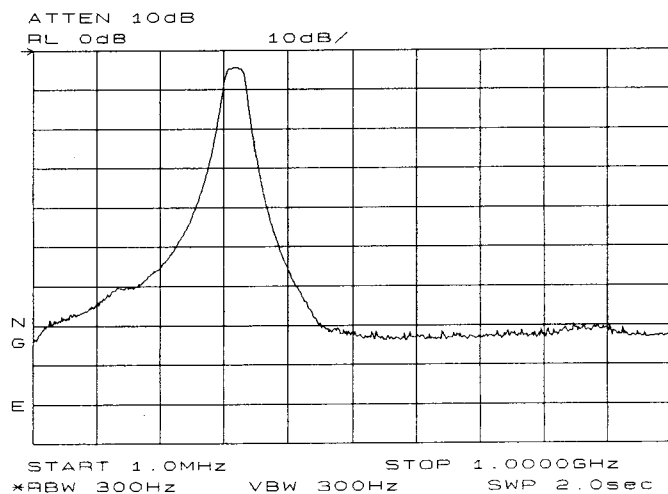

Figure 3-23. Normalized Trace

7. Measure the range using the delta markers. Press **PEAK SEARCH**, **MARKER DELTA**, and use the knob to position the second marker in the rejection area of the bandpass filter as shown in Figure 3-24.

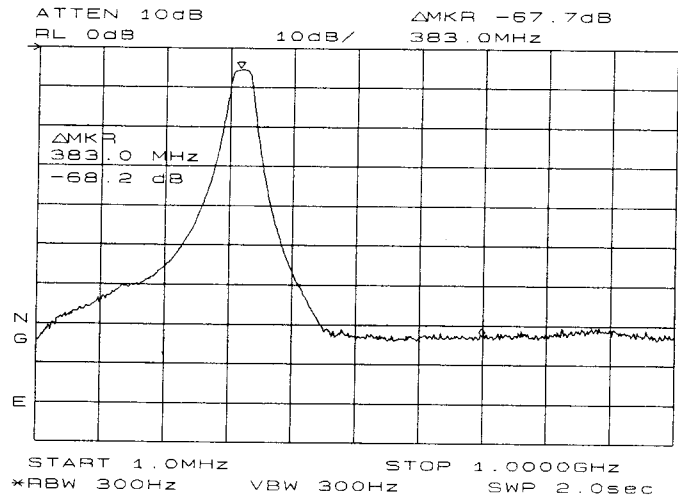

Figure 3-24. Measure the rejection range with delta markers.

8. When normalize is active, there is also a change to the amplitude menu. **REF LVL** is replaced by **NORM REF LVL**, and the **RANGE LVL** softkey appears.

NORM REF LVL, like **NORM REF POSN**, is a trace math function which allows you to change the position of the normalized trace, within the range of the graticule (see Figure 3-25). It does not change any spectrum-analyzer settings, so your measurement remains calibrated. However, using these two trace math functions may mean that the top of the screen does not necessarily represent the gain-compression limit.

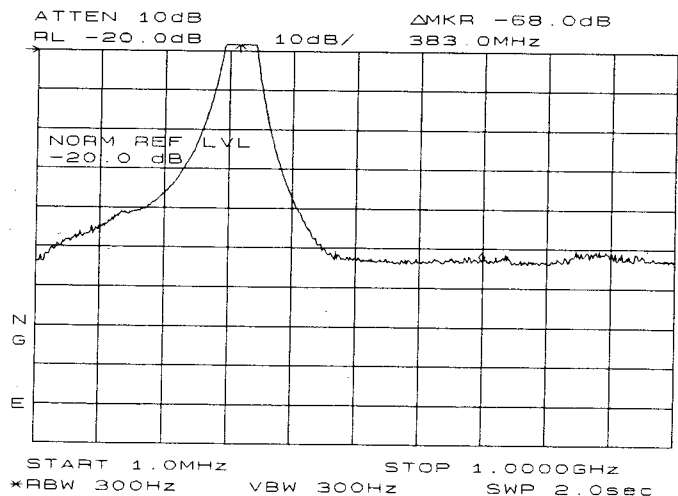

Figure 3-25. **NORM REF LVL** adjusts the trace without changing analyzer settings.

RANGE LVL increases the dynamic range of the measurement, by changing the input attenuator and IF gain. It is equivalent to **REF LVL**, which is used in signal analysis

measurements. Both **RANGE LVL** and **REF LVL** ensure that the input signal is not in gain compression.

To increase the dynamic range of the measurement, press **RANGE LVL**. Note that while increasing the dynamic range, more errors are introduced into the measurement, such as attenuator switching, etc. However, as Figure 3-26 shows, the dynamic range level has increased by 18 dB, when using **RANGE LVL**.

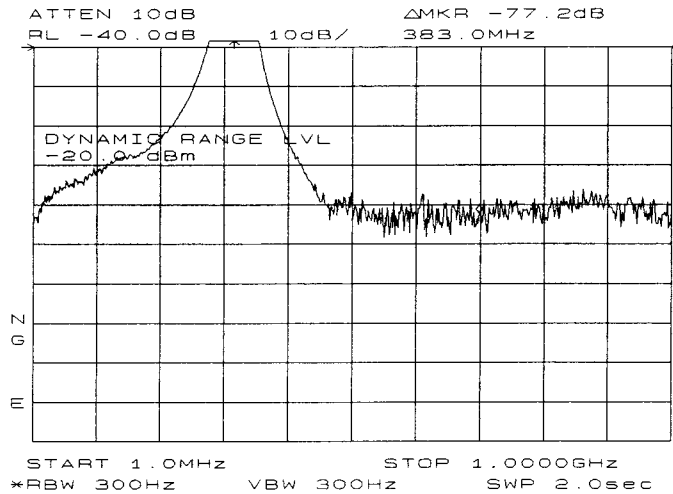

Figure 3-26. Increase the dynamic measurement range by using **RANGE LVL.**

If the actual measured signal is beyond the gain-compression limit, or below the bottom graticule of the display, an error message will appear in the lower right-hand corner of the display. In the case shown here, the passband information is adjusted off-screen in order to view the rejection range with better resolution. Therefore, changing the analyzer settings to raise the passband information off the top of the screen will result in the error **ERR 903 A>DLMT** being displayed.

ERR 904 B>DLMT may also appear, when in normalized mode, if (1) calibration trace is off-screen, (2) no calibration has been performed after a preset, or (3) trace B is blank. To clear this error, and ensure a calibrated measurement, recalibrate and perform a store-thru operation.

Another example of the difference between range level and the normalized reference level is illustrated below. The normalized frequency response of a preamplifier is shown in Figure 3-27. The normalized trace is cut off at the top of the graticule. This is confirmed by the step up **▲** key when a marker is activated, and the **ERR 903 A>DLMT** error appears in the error message block.

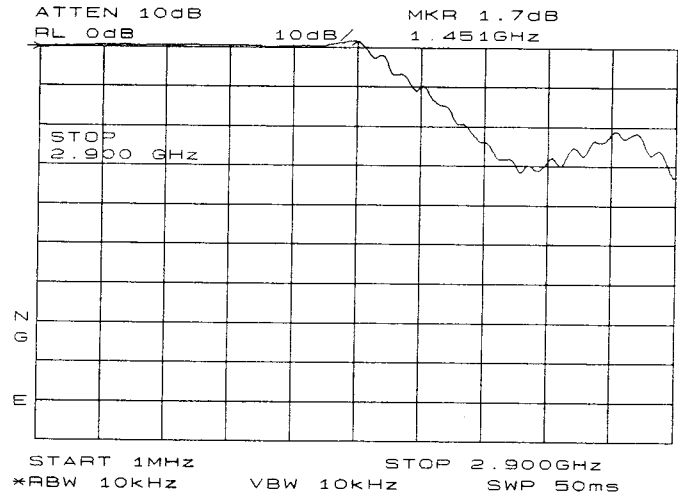

Figure 3-27. Normalized Frequency Response Trace of a Preamplifier

By increasing **NORM REF LVL** to 30 dB, as shown in Figure 3-28, the trace moves down on the screen. Note the following three instrument parameters: (1) the input attenuator value still remains at 10 dB, (2) the marker-amplitude readout displays 13.2 dB, and (3) the **ERR 903 A>DLMT** error message is still displayed, even though the signal appears to be fully within the graticule.

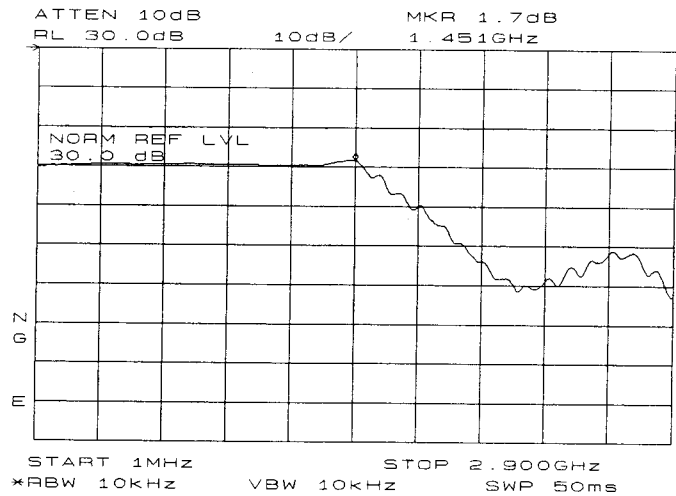

Figure 3-28. **NORM REF LVL is a trace function.**

After returning the **NORM REF LVL** to 0 dB, increase **RANGE LVL** to 30 dB. As shown in Figure 3-29, the trace moves fully within the graticule. Again, note the following three instrument parameters: (1) the input attenuator value has changed to 40 dB, (2) the marker-amplitude readout displays -6.3 dB, and (3) the ERR 903 A>DLMT error message no longer appears.

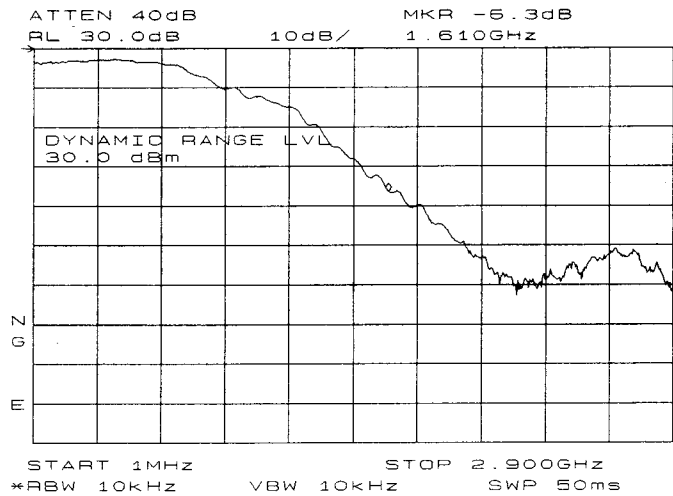

Figure 3-29. RANGE LVL adjusts analyzer settings for compression-free measurements.

Hence, Figure 3-28 shows that **NORM REF LVL** is a trace function that can position the active trace without changing analyzer settings. The ERR 903 A>DLMT error message is an indicator that the actual measured trace may fall outside of the analyzer's measurement range with the current settings. By adjusting **RANGE LVL**, thereby changing the input attenuator and IF gain, compression-free measurements are assured.

Example 5: External Millimeter Mixers (unpreselected)

External millimeter mixers can be used to extend the frequency coverage of the HP 8560A, HP 8561B, and HP 8563A. (It should be noted that an HP 8560A Option 002 tracking generator does not have external-mixer capabilities.) Hewlett-Packard manufactures external mixers that do not require biasing and cover the frequency ranges from 18 GHz to 110 GHz. Other manufacturers sell mixers that extend to 325 GHz, but may require biasing. The HP 8560A, HP 8561B, and HP 8563A will support both types of mixers.

Spectrum Analyzer Functions Used

The HP 8560A, HP 8561B, and HP 8563A contain an extensive menu of functions that help the millimeter user. This example explains how to connect external mixers to the spectrum analyzer, choose the band of interest, store conversion-loss factors, and how to use its automatic signal-identification functions.

Stepping through the Measurement

Figure 3-30 illustrates how to connect an external harmonic mixer to the spectrum analyzer.

Caution



The spectrum analyzer local-oscillator output power is +16.5 dBm. Be sure that your external harmonic mixer can accommodate this power level before connecting it to the analyzer.

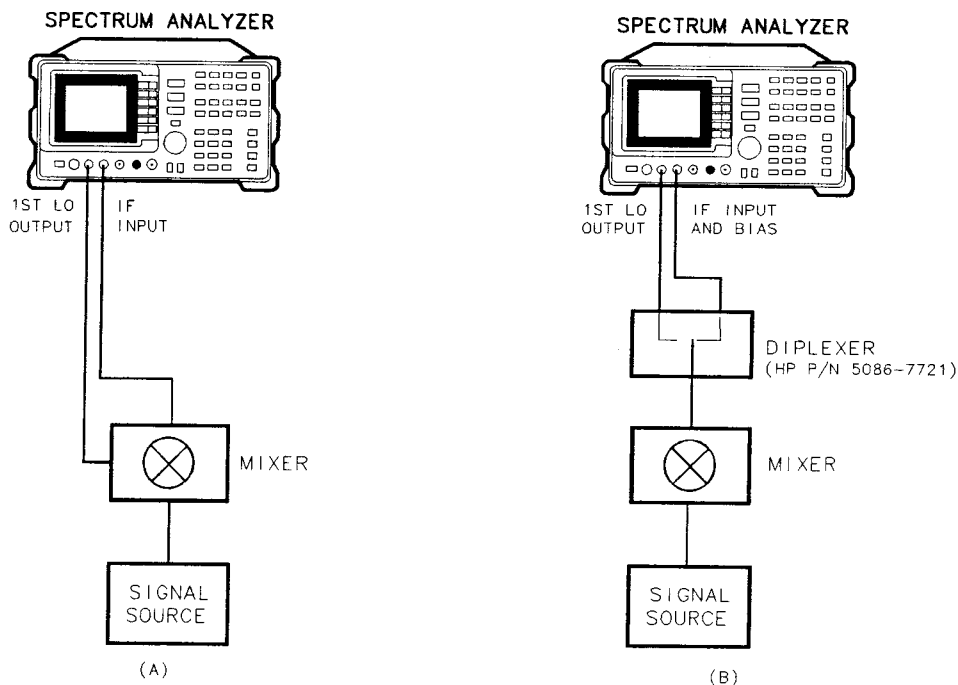

Figure 3-30. External Mixer Setup (a) without Bias; (b) with Bias

Note

Good quality shielded, SMA-type cables should be used to connect the mixer to the spectrum analyzer to ensure that no signal attenuation occurs. HP 5064-5458 SMA-type cables may be used. Do not overtighten the cables.

1. Specify unpreselected external mixing by pressing **CONFIG**, then **EXT MXR PRE UNPR** until **UNPR** is selected. To select a frequency above 18 GHz, press **AUX CRTL**, **EXTERNAL MIXER** to set the analyzer to external mixer mode, and then enter the desired frequency directly using the center-frequency function. Note in Table 3-1 that some frequencies overlap and fall into two bands. To be sure that the desired band is selected, refer to Table 3-1 and select the desired frequency band, then use the full band function to enter this band. In the external mixer menu, press **FULL BAND**, then press the step up **▲** key until the letter preceding **BAND** in the active function area corresponds to the desired frequency band. In this example, we'll take a look at U-band, which ranges from 40 GHz to 60 GHz, as depicted in Figure 3-31. The **LOCK HARMONIC** function "locks" the spectrum analyzer in that band, ensuring that the spectrum analyzer sweeps only the chosen band. The **LOCK ON OFF** softkey is automatically set to ON when **FULL BAND** is pressed.

Table 3-1. External Mixer Frequency Ranges

Frequency Band	Frequency Range (GHz)	Mixing Harmonic	Conversion Loss
K	18.0 to 26.5	6-	30 dB
A	26.5 to 40.0	8-	30 dB
Q	33.0 to 50.0	10-	30 dB
U	40.0 to 60.0	10-	30 dB
V	50.0 to 75.0	14-	30 dB
E	60.0 to 90.0	16-	30 dB
W	75.0 to 110.0	18-	30 dB
F	90.0 to 140.0	24-	30 dB
D	110.0 to 170.0	30-	30 dB
G	140.0 to 220.0	36-	30 dB
Y	170.0 to 260.0	44-	30 dB
J	220.0 to 325.0	54-	30 dB

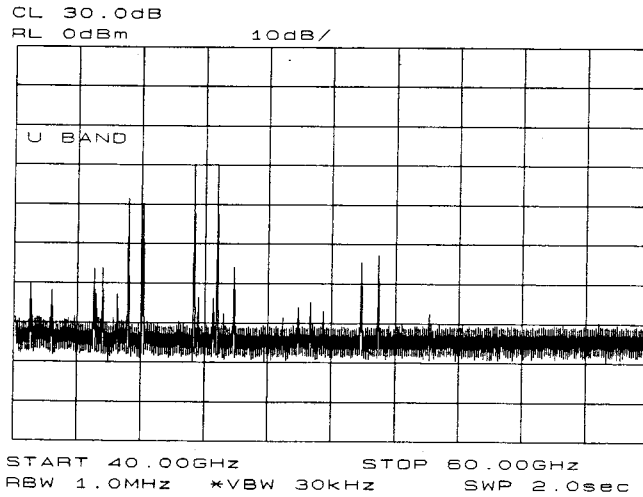

Figure 3-31. Select the band of interest.

- Table 3-1 lists default conversion-loss values that are stored in the analyzer for each frequency band. These values approximate the values for the HP 11970 Series Mixers. Other conversion-loss values may be entered into the spectrum analyzer in two ways. The first allows the user to save the average conversion-loss value for the entire band using **AVERAGE CNV LOSS**. To activate this function, press **AUX CTRL**, **EXTERNAL MIXER**, **AMPTD CORRECT**, **AVERAGE CNV LOSS**, then enter the appropriate average conversion-loss value. On HP 11970 Series Harmonic Mixers, these values are charted on the mixer. The U-band mixer used for this example had an average conversion loss of 35 dB, as depicted in Figure 3-32.

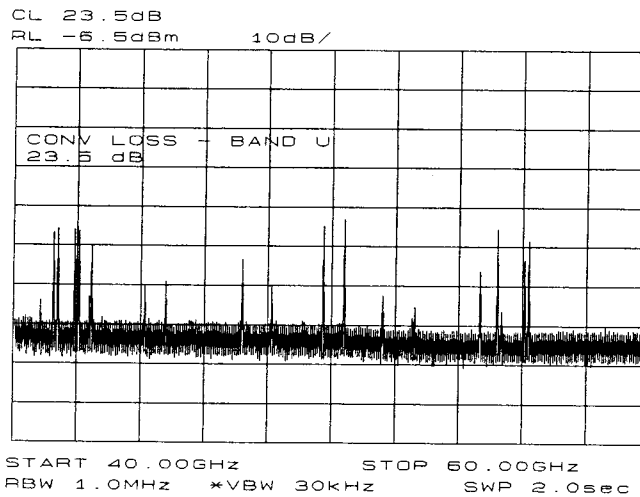

Figure 3-32. Store and correct for conversion loss.

The second method for storing conversion-loss information uses the **CNV LOSS VS FREQ** softkey. This method allows you to save individual conversion-loss data points at specific intervals across the harmonic band. To view or enter a conversion-loss data point, press **CNV LOSS VS FREQ**, enter the conversion-loss data at the frequency shown, and use the step up **▲** key to step through the band and enter the conversion loss at each step.

SIGNAL IDENTIFICATION (unpreselected mixers only)

3. The IF output of a harmonic mixer contains many mixer products (frequencies of $LO \pm \text{source}$, $2LO \pm \text{source}$, $3LO \pm \text{source} \dots nLO \pm \text{source}$). As a result, within a single harmonic band, a single input signal can produce many responses, only one of which is valid. These responses come in pairs, where the members of the valid pair are spaced 621.4 MHz apart (see Figure 3-33) and the right-most member for the pair is the correct response (for this analyzer, the left member of a pair is not valid).

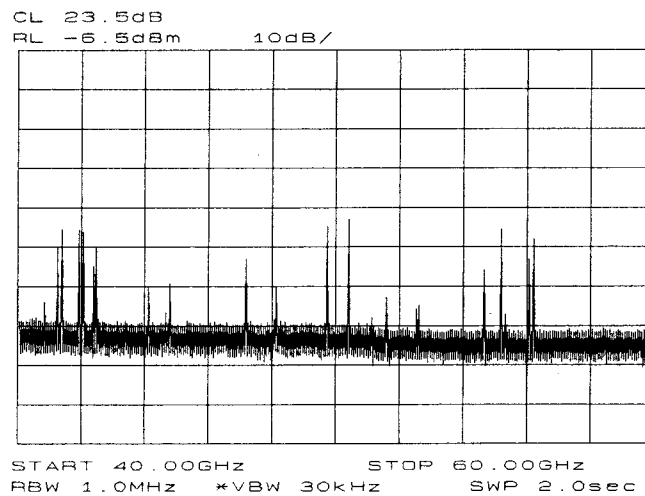

Figure 3-33. Signal Responses Produced by a 50 GHz Signal in U Band

Signal-identification routines are built into the spectrum analyzer which identify the signal and image. The frequency shift method of identifying valid signals employs the spectrum-analyzer function **SIG ID ON OFF**. When using this function, smaller spans will yield more accurate measurements. Span down to 50 MHz, then press **AUX CTRL**, **EXTERNAL MIXER**, **SIGNAL IDENT**, and **SIG ID ON OFF** to ON. Any signal not produced by the currently selected harmonic will be shifted horizontally on alternate sweeps (see Figure 3-34); so when viewing the display, on alternate sweeps, the signal will appear, then not appear at the frequency of interest. The correct signal that has been produced by the selected harmonic will be shifted in a vertical direction only, as in Figure 3-35.

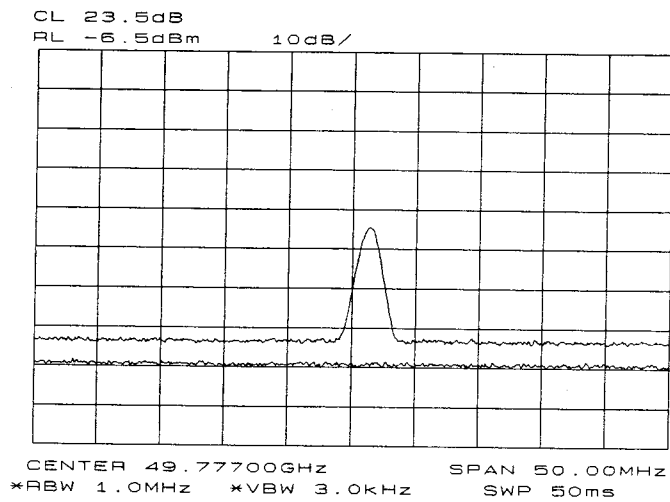

Figure 3-34. Response for Invalid Signals

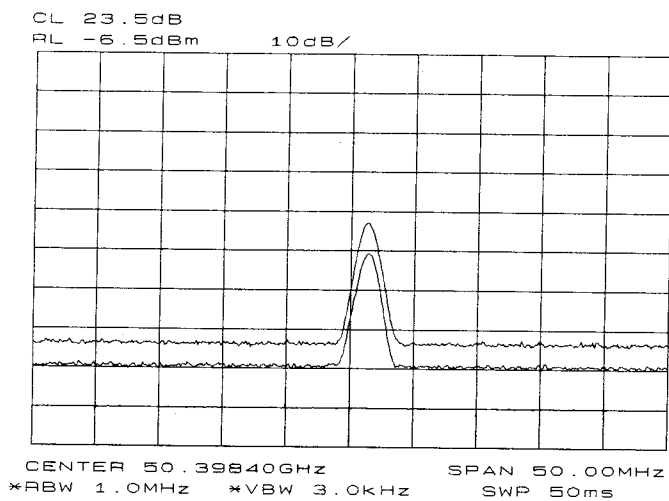

Figure 3-35. Response for Valid Signals

There is also a function for identifying signals in wide frequency spans. This function, **SIG ID AT MKR**, employs a harmonic search method of signal identification. **SIG ID AT MKR** automatically determines the proper frequency of a signal and displays its value on the spectrum analyzer. Activating **SIG ID AT MKR** on an image will yield a reading in the active block, as depicted in Figure 3-36. The true signal frequency is given with an identifier that the marker resides on an image. If the marker is placed on a true signal, and **SIG ID AT MKR** is activated, the signal frequency will appear without the IMAGE notation, as shown in Figure 3-37. To activate **SIG ID AT MKR**, place a marker on a signal and press **AUX CTRL**, **EXTERNAL MIXER**, **SIGNAL IDENT**, then **SIG ID AT MKR**.

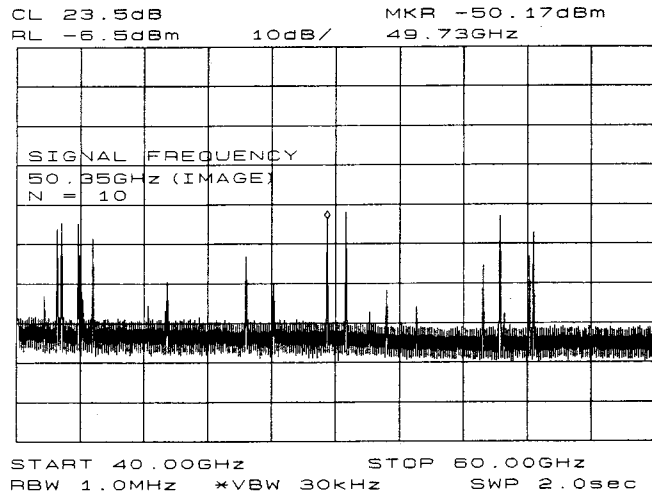

Figure 3-36. SIG ID AT MKR Performed on an Image Signal

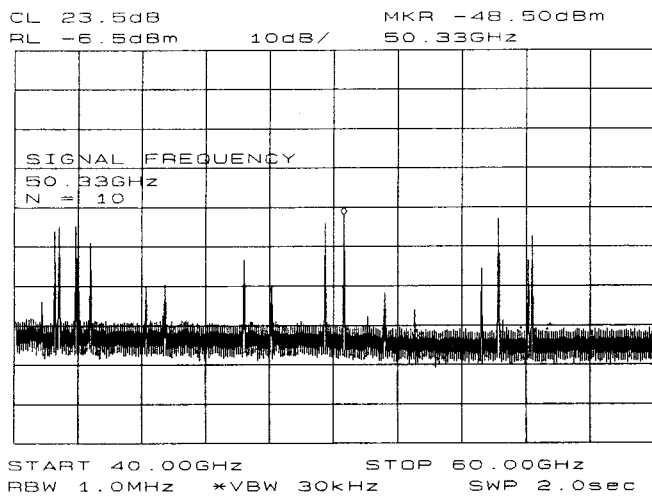

Figure 3-37. SIG ID AT MKR Performed on a True Signal

- To exit the external mixer mode, press **AUX CTRL**, then **INTERNAL MIXER**.

BIAS

The HP 11970A Series Harmonic Mixers mentioned in the section above, do not require bias. Mixers requiring bias can also be used with the HP 8560A, HP 8561B, and HP 8563A. Bias gives these mixers minimum conversion loss; however, bias must be adjusted for every measurement made. Mixers requiring bias are connected as shown in Figure 3-30 (with mixer bias supplied via the IF line). To measure a signal, access a band as described above. To activate the bias, press **AUX CTRL**, **EXTERNAL MIXER**, and **BIAS**; then press the softkey corresponding to the bias polarity (positive or negative) that your mixer requires. Use the knob on the spectrum analyzer to adjust the bias and to peak the signal for maximum amplitude. Activate the signal identification method that you desire. On most mixers, the optimum bias varies with frequency, so the bias should be adjusted for every signal measured.

Warning



The open-circuit bias voltage can be as great as +3.5 V through a source resistance of 300 ohms. Such voltage levels may appear when recalling an instrument state in which an active bias has been stored.

Note



The bias value that appears on the spectrum analyzer display is expressed in terms of short-circuit current (that is, the amount of current that would flow if the IF line were shorted to ground). The actual amount of current flowing into the mixer will be less.

Example 6: Adjacent Channel Power Measurement

What is Adjacent Channel Power (ACP)?

Minimizing the interference of one transmitter with another is the objective behind the adjacent channel power measurement. The adjacent channel power measurement examines the leakage power transmitted into an adjacent channel, that is, the channel next to the carrier channel.

The result of the adjacent channel power measurement is the adjacent channel power leakage ratio, which is the ratio of the leakage power in the adjacent channel to the total power transmitted by the transmitter.

Spectrum Analyzer Functions Used

The adjacent channel power measurement makes full use of the processing power of the HP 8560 series of spectrum analyzers. In addition to automatically setting up the spectrum analyzer for the measurement, the spectrum analyzer computes the sum of the power over the range of displayed frequencies in the adjacent channel, and then displays the calculated ACP leakage ratio, the total transmitted power, and the channel spacing and channel bandwidth with which the measurement was made.

Stepping through the Measurement

Provide a signal to the spectrum analyzer by either connecting a radio directly, or coupling a signal from the radio via an antenna. For the purposes of this demonstration, the calibrator will be used as the signal source.

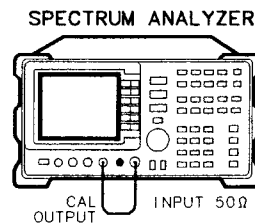

APLE_M6L

Figure 3-38. Adjacent Channel Power Measurement Test Setup

In this example, we will be using a transmitter with a carrier frequency of 300 MHz. The signal that we will be examining has a channel bandwidth of 14.0 kHz and a channel spacing requirement of 20.0 kHz, as shown below.

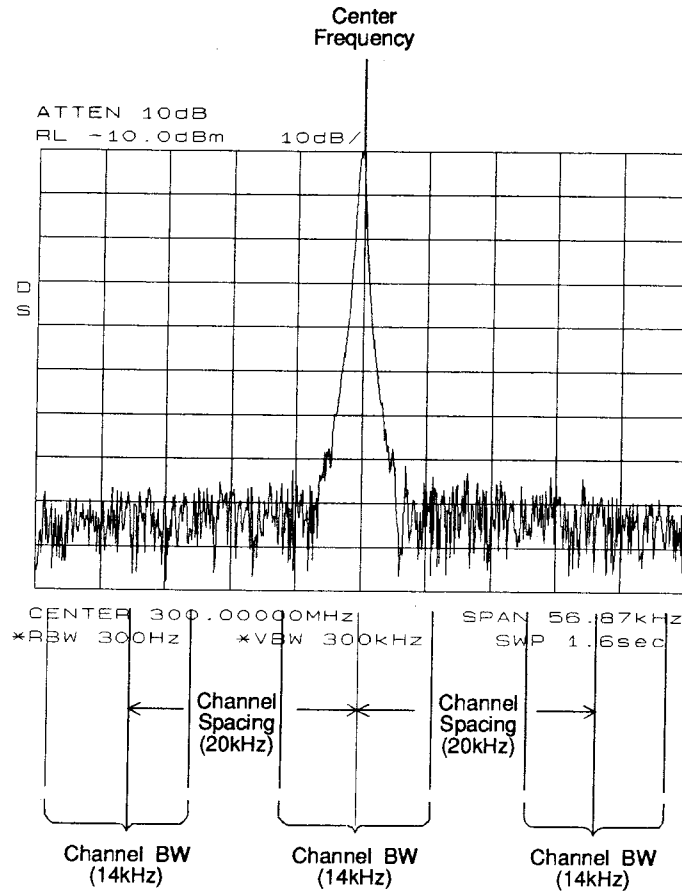

Figure 3-39. Adjacent Channel Power Parameters

1. Press **PRESET** on the spectrum analyzer to start the measurement from a preset state.
2. Input the frequency of the transmitted carrier by pressing **FREQUENCY**, **CENTER FREQ**, and entering the center frequency of the carrier signal (in this case, 300 MHz for the calibrator signal).
3. Press **AMPLITUDE**, then the step down **▼** key once to set the signal reference level to -10 dBm.
4. Press **MEAS/USER**, then **ACP MENU** to access the adjacent channel power menu of softkeys.
5. Press **SPACING/BANDWIDTH** to access the channel spacing and channel bandwidth softkeys, then press **20.0kHz/14.0kHz**.

Note



Common channel spacings and bandwidths have been assigned softkeys. If you are testing a transmitter with different channel spacing/bandwidth requirements other than 12.5 kHz/8.5 kHz, 20.0 kHz/14.0 kHz, or 25.0 kHz/16.0 kHz, then **CHANNEL SPACING** and **CHANNEL BANDWIDTH** can be used to enter new parameters.

6. Press **PREV MENU** to return to the adjacent channel power menu of softkeys.

- Press **AUTO ACP MEASURE** to activate the automatic adjacent channel power measurement. **AUTO ACP MEASURE** reconfigures the measurement parameters, optimizing the frequency span, resolution bandwidth, video bandwidth, and detector of the spectrum analyzer.

Numerical results for the ACP leakage ratio in the upper and lower adjacent channels are listed in the active function area, along with the channel spacing and channel bandwidth. The total transmitted power measured, and the maximum ACP ratio (of the upper and lower adjacent channels) are listed in the title area in the upper right corner of the display.

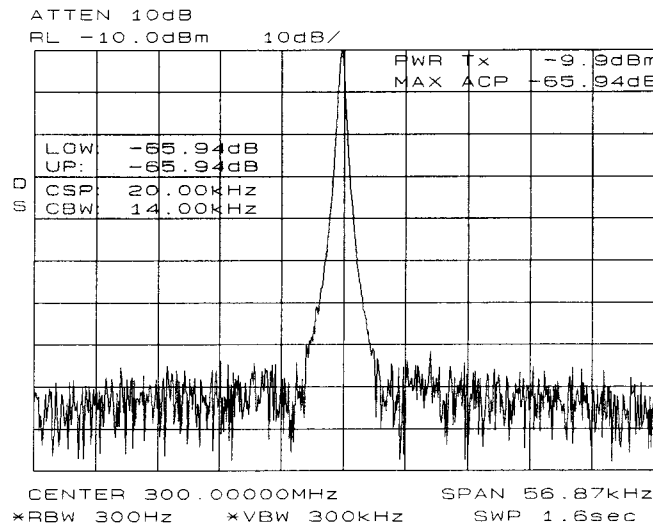

Figure 3-40. Adjacent Channel Power Measurement Results

Note



The adjacent channel power measurement can also be performed with the spectrum analyzer settings that you choose. For example, if you want to perform the ACP measurement with a specific resolution bandwidth, or in a particular span, set the analyzer up in the state that you want, then use the **ACP COMPUTE** softkey. **ACP COMPUTE** performs the adjacent channel power measurement without changing the instrument state.

- Set **ACPGRAPH ON OFF** to ON to see a graphical display of the adjacent channel power ratio, for the selected channel bandwidth, as a function of the channel spacing. A delta marker is activated, with the reference marker at the center frequency, and the marker spacing equal to the channel spacing.

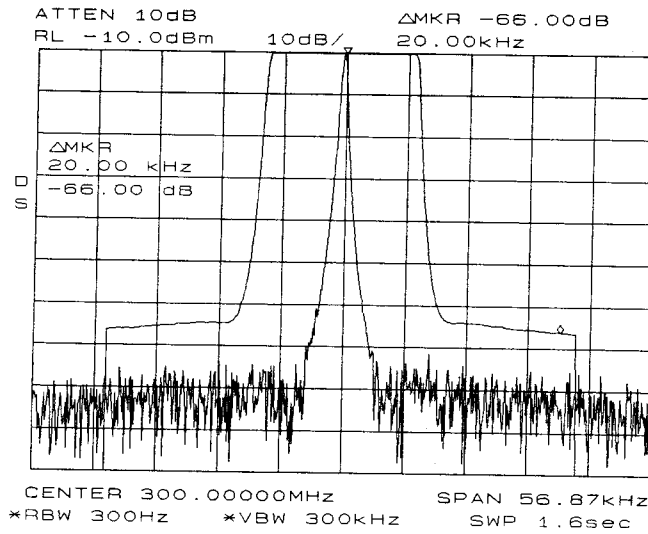

Figure 3-41. ACP Graph Display

This graph allows you to see how rapidly the ACP ratio changes with channel spacing. The ACP graph is not defined for channel spacings where the graph is drawn at the bottom graticule line. For these points, the channel bandwidth would include frequencies beyond the edges of the screen, where no data was taken.

9. Press **EXIT ACP** when finished with the adjacent channel power measurement, in order to restore the instrument state to its condition previous to making an ACP measurement.



Programming

This chapter describes how to operate an HP 8560A, HP 8561B, and HP 8563A Portable Spectrum Analyzer by remote, computer control. The topics covered in this chapter are listed below:

- Setup procedure for remote operation
- Communication with the system
- Initial program considerations
- Program timing
- Data transfer to computer
- Input and output buffers
- Math functions
- Creating screen titles
- Generating plots and prints remotely
- Monitoring system operation (service requests)

Setup Procedure

The following procedure describes how to connect your equipment for remote operation of the HP 8560A, HP 8561B, and HP 8563A Spectrum Analyzers.

Note



Refer to the Installation and Verification Manual for more information on installing, configuring, and addressing the system.

1. Connect computer, spectrum-analyzer system, and other peripherals with HP-IB cables. The HP 85620A Mass Memory Module can be attached for down-loadable programming (DLP) capabilities. Set the analyzer to OFF before installing or removing any option module.
2. After the HP-IB cables are installed, reset all instruments connected to the bus. (If you are not sure how to reset a device, switch its line power off, then on, to reset it.)
3. Check the HP-IB address of the spectrum analyzer by pressing **CONFIG**, then **ANALYZER ADDRESS**. Note that for examples in this section, HP-IB address 18 is used.

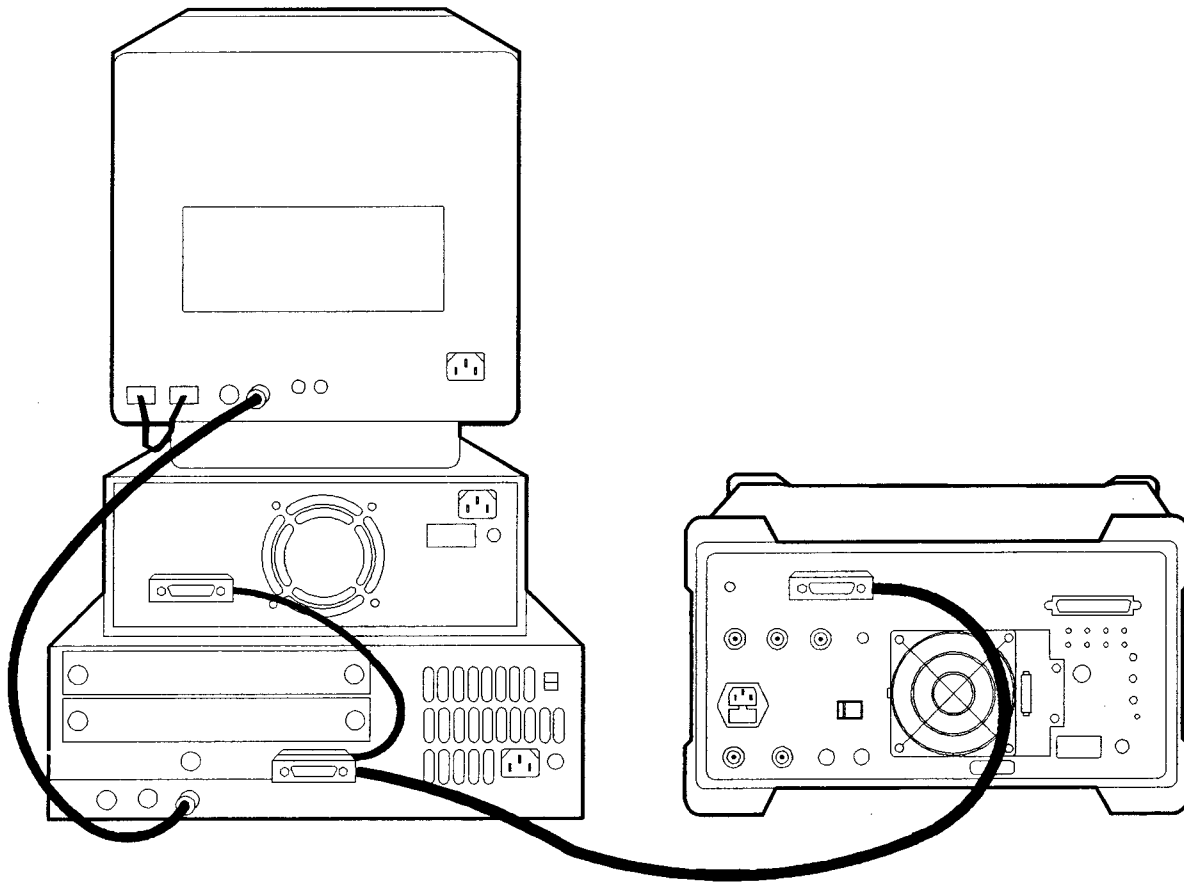

Figure 4-1. HP 8560A connected to an HP 9000 Series 300 computer.

Communication with the System

This section develops some fundamental techniques for controlling the spectrum analyzer and obtaining reliable measurement results. The spectrum analyzer is remotely controlled with commands that correspond in general to front-panel softkey functions.

It is important to understand how messages are communicated to the spectrum analyzer; therefore, enter and output statements and command syntax discussed in this chapter should be understood before proceeding. HP BASIC is used for all examples in this manual.

Executing Remote Commands

The computer communicates with the spectrum analyzer system on the Hewlett-Packard Interface Bus (HP-IB), using HP BASIC **OUTPUT** and **ENTER** statements.

An **OUTPUT** statement tells the computer to send a message to the spectrum analyzer. For example, executing the statement below sets the center frequency to 300 MHz and the frequency span to 1 MHz.

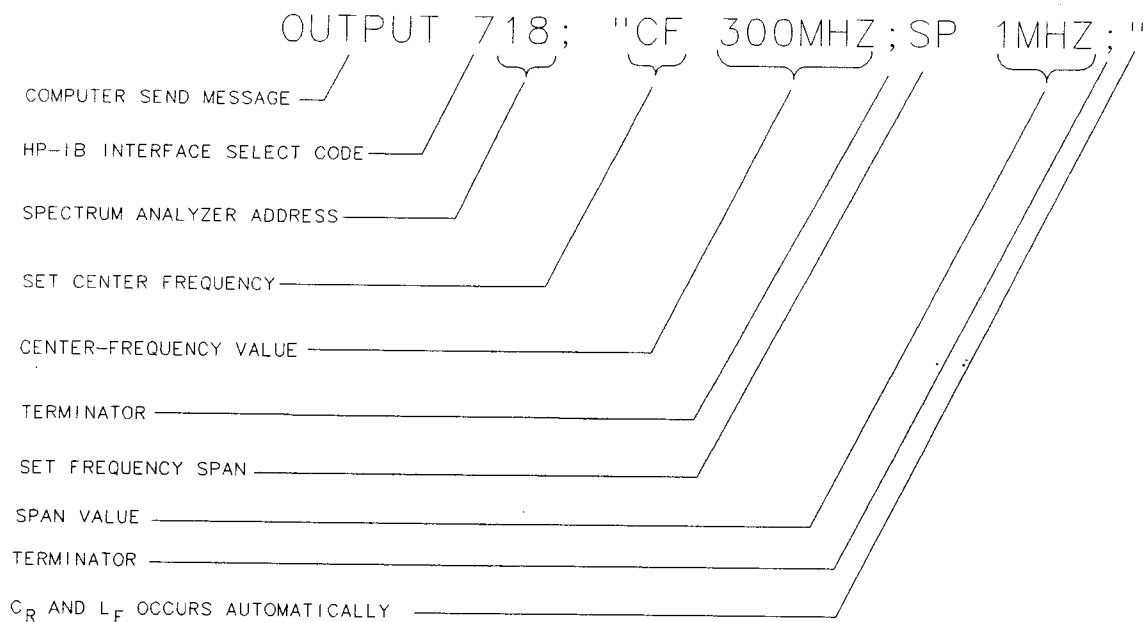

An **ENTER** statement used in conjunction with a spectrum-analyzer query returns information to the computer. To return the center-frequency value to the computer, first form a query by adding a question mark (?) to the command:

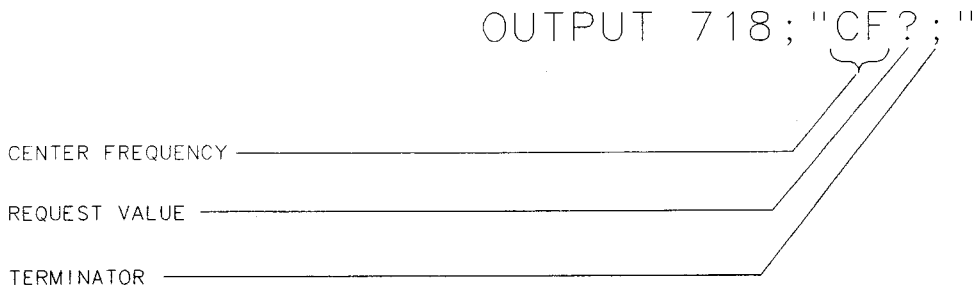

Next, the **ENTER** statement is used to assign the returned value to a variable in the computer:

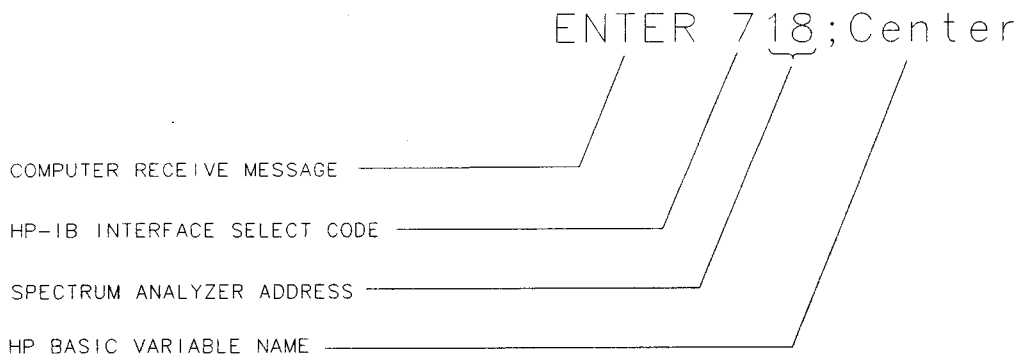

The value of the center frequency above is placed in the variable named "Center." The variable may be printed, stored, or used for other computer functions.

Syntax Requirements

All of the program examples in this manual show recommended command syntax. All spectrum analyzer commands must be constructed according to specific syntactical rules which are outlined in Chapter 5, "Language Reference." Chapter 5 lists all of the remote spectrum analyzer commands in alphabetical order, and contains a syntax diagram for each command. Refer to Appendix D for a complete alphabetical command listing of all valid HP 8560A, HP 8561B, and HP 8563A Spectrum Analyzer remote commands.

Local and Remote Control

Whenever the spectrum analyzer is remotely addressed, all front-panel keys and softkeys are disabled, except for the one HP-IB related softkey **RMT LCL**. When the analyzer is remotely addressed, the remote mode (RMT) is selected. Pressing **RMT LCL** until "LCL" is underlined returns the analyzer to local mode, clears the softkey menu, and reactivates front-panel operation. Executing the HP BASIC statement LOCAL achieves the same result.

Note



Local mode should not be activated, via the **RMT LCL** softkey, until other processes are complete (for example, instrument preset, recall state, fast Fourier transform, and so on). Using the LOCAL command via HP-IB may require the HP BASIC command WAIT to precede it. Executing a WAIT statement before the LOCAL command ensures that sufficient time has been allocated for full execution of other commands before local mode is activated.

Program timing may be affected when using the LOCAL command at the end of a command string or at the end of a program without preceding it with a WAIT command. In this case, all commands in the program may not be executed and errors that are generated may not be reported due to the fact that the analyzer has exited remote mode as soon as the LOCAL command is received.

Initial Program Considerations

Programs should begin with a series of HP BASIC statements and signal analyzer commands that form a good starting point for measurements. Some initial program considerations are discussed below.

CLEAR is an HP BASIC statement that puts an HP-IB instrument (for example, HP 8560A) in a known state by clearing the input buffer, the output buffer, and the command parser of the specified instrument so that it is ready for operation. This command may be used to clear devices on the bus singly or in unison. It is often desirable to clear only one instrument so that other instruments on the bus are not affected. Refer to the "Program Timing" section, in this chapter, for more information.

To clear only the spectrum analyzer, CLEAR 718 should be used.

To clear all devices at select code 7, CLEAR 7 must be used.

IP, the **instrument preset** command, presets all parameters of the spectrum analyzer for the current mode of operation, and provides a good starting point for all measurement processes. Executing IP is actually the same as executing a number of commands that set the spectrum analyzer to a known state.

Program Timing

Most remotely-controlled measurements require control of the sweep. The TS (take sweep) command initiates a sweep when the trigger conditions are met. When TS is executed as part of a command sequence, the analyzer starts and completes one full sweep before the next analyzer command is executed.

Use the SNGLS (single sweep) command to maintain absolute control over the sweep and to reduce execution time. Once SNGLS activates the single-sweep mode, TS may be used to initiate a sweep only when necessary.

Note



If a TS command is executed, but the trigger conditions are not met, the spectrum analyzer will not respond on HP-IB. The analyzer continues to take commands into its input buffer, however the commands are not processed at this time. This may also appear to happen if the sweep time is very long. If this occurs, the HP BASIC CLEAR (that is, CLEAR 718) statement may be used to abort the TS command. (CLEAR also causes an instrument preset.)

Since many remote commands process trace information, updating trace information with TS becomes important whenever the input signal or analyzer settings change. Use TS to update the trace *after* the analyzer settings or input signals change, but *before* the trace information is returned to the computer or processed by other commands, like trace math or marker commands.

When developing measurement algorithms with the front-panel controls, use the single-sweep function to simulate the effect of the TS command updating the trace. Pressing either **SGL SWP** or **SINGLE**, and waiting until the end of the sweep, is the same as executing TS via remote control during the single-sweep mode.

The following examples demonstrate the importance of updating trace information with the TS command.

EXAMPLE: Change the measurement range but do not update trace information.

Connect the calibrator signal to the analyzer INPUT 50 Ω before performing this example.

```
10 CLEAR 718
20 OUTPUT 718;"IP;SNGLS;TS;"           Initialize analyzer.
30 OUTPUT 718;"CF 300MHZ;SP 1MHZ;"     Change measurement range.
40 END
```

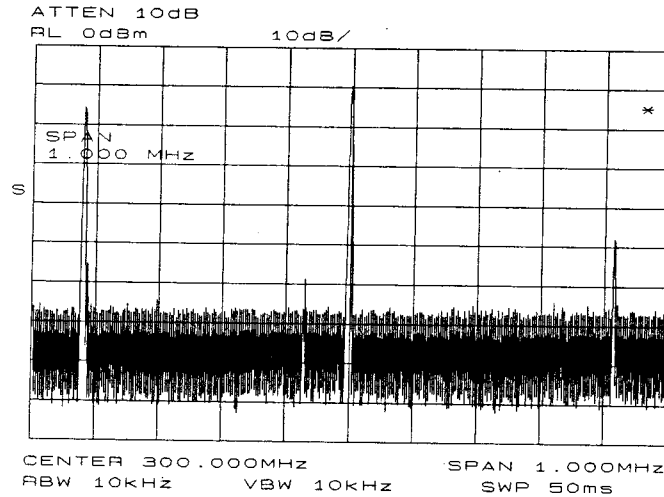

Figure 4-2. Invalid Trace Information

The previous program example does not measure with the new analyzer settings as depicted by the data-invalid indicator "*" in the upper right-hand corner. To obtain valid trace information, the trace must be updated with the TS command. Here is the program again, corrected to include the TS command.

EXAMPLE. Change the measurement range, then update trace information.

Connect the calibrator signal to the analyzer INPUT 50Ω before performing this example.

```

10 CLEAR 718
20 OUTPUT 718;"IP;SNGLS;"           Initialize analyzer.
30 OUTPUT 718;"SP 1MHZ;CF 300MHZ;" Change measurement range.
40 OUTPUT 718;"TS;"                 Measure with trace A.
50 END

```

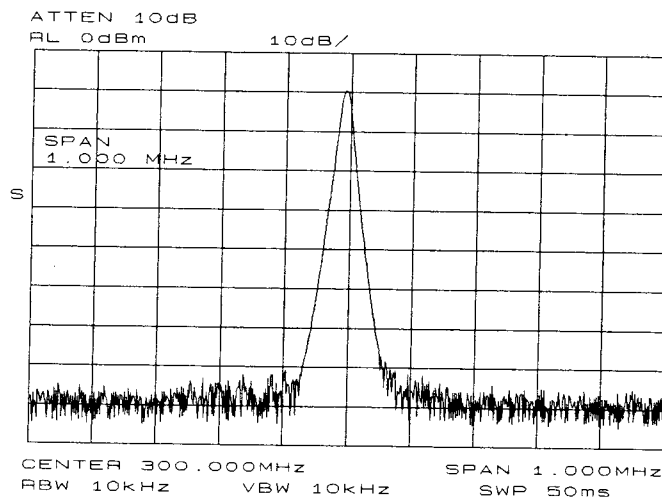

Figure 4-3. Updated Trace Information

The next example processes trace information with a marker command, MKPK HI (marker peak highest), which selects the highest amplitude level in the trace. Since the program changes the measurement range, the trace information must be updated with TS before MKPK HI is executed.

EXAMPLE. Use TS to update trace information before using the marker commands.

Connect the calibrator signal to the analyzer INPUT 50Ω before performing this example.

```

10 CLEAR 718
20 OUTPUT 718;"IP;SNGLS;"           Initialize analyzer.
30 OUTPUT 718;"SP 1MHZ;CF 300MHZ;RL -5DBM;" Change measurement range.
40 OUTPUT 718;"TS;"                 Update trace.
50 OUTPUT 718;"MKPK HI;"           Place marker on highest signal
                                     level.

60 END

```

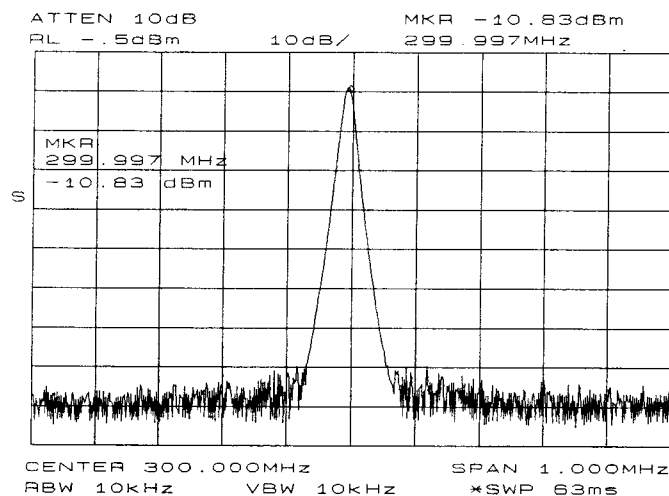

Figure 4-4. Update trace information with TS before executing marker commands.

As the example shows, TS is executed *after* analyzer settings are changed, but *before* trace information is processed.

There are two commands that change the measurement range indirectly, MKCF (marker to center frequency) and MKRL (marker to reference level). They set the center frequency and reference level equal to the marker frequency and amplitude, respectively. If valid trace information is needed, a TS command must be executed after these commands are executed.

In all cases, executing TS invokes at least one entire sweep. However, TS invokes more than one sweep when certain commands are active, such as SP (frequency span) when MKTRACK (marker tracking) is turned on.

Note To ensure that all processes have been completed (for example, MKFC), take a sweep and then query the data.



Data Transfer to Computer

An important part of spectrum-analyzer remote operation is sending and receiving trace data to and from a computer via HP-IB. There are three requirements that apply to all trace data transfers.

1. Trace length

HP 8560A, HP 8561B, and HP 8563A traces are composed of 601 data points, or trace elements. This is the length of all traces and cannot be changed. When transferring trace data to or from a computer, trace-data array dimensions must be set to 601 elements.

2. Trace conditions

Trace data is of little value if you do not also know the trace conditions from which the data was taken. The five conditions that you must store in addition to the trace data are the start and stop frequencies, the reference level, the amplitude scaling, and the absolute amplitude units. You may want to store additional conditions such as the resolution bandwidth, attenuation, or sweep time. Example 1 below queries the spectrum analyzer for the trace conditions shown on the display and stores them. Example 2 shows how to return this data to the analyzer. These procedures, which you may find useful and are referred to by subroutine name, are used throughout the programming examples in this chapter.

EXAMPLE 1

```
10 SUB Get_settings(Fa,Fb,Rl,Rb,Vb,St,Lg,Aunits$)
20 OUTPUT 718;"FA?;FB?;RL?;RB?;VB?;ST?;LG?;AUNITS?;"
30 ENTER 718 USING "K";Fa,Fb,Rl,Rb,Vb,St,Lg,Aunits$
40 SUBEND
```

EXAMPLE 2

```
10 SUB Setup_analyzer(Fa,Fb,Rl,Rb,Vb,St,Lg,Aunits$)
20 OUTPUT 718;"FA ";Fa;"HZ;"
30 OUTPUT 718;"FB ";Fb;"HZ;"
40 OUTPUT 718;"RL ";Rl;"DBM;"
50 OUTPUT 718;"AUNITS ";Aunits$;";"
60 OUTPUT 718;"RB ";Rb;"HZ;"
70 OUTPUT 718;"VB ";Vb;"HZ;"
80 OUTPUT 718;"ST ";St;"SEC;"
90 If Lg=0 THEN
100 OUTPUT 718;"LN;"
110 ELSE
120 OUTPUT 718;"LG ";Lg;" dB;"
130 END IF
140 SUBEND
```

3. Specify the data format before transferring data.

Use the TDF (trace data format) command to specify the format before sending data from the spectrum analyzer to the computer. The examples in this section illustrate how to use this command.

The examples in this section use the TRA (trace A) command. This command transfers data to and from trace A. The TRB (trace B) command is also available for transferring trace B data. It is possible to read data from trace A and then send it to trace B, and vice versa. For simplicity, this capability is not reflected in the programming examples in this section.

The analyzer returns information as decimal values in fundamental units shown in Table 4-1. The analyzer does not automatically apply these units to data received from the computer; the user *must* specify units.

Table 4-1. Units for Returned Data

Measured Data	Fundamental Unit
Frequency	Hz
Power	dBm, dBmV, dB μ V, W
Amplitude	dBm, dBmV, dB μ V, W, V
Ratio	dB, unitless (voltage ratio)
Voltage	V
Time	s

As indicated in Table 4-1, power and amplitude information may be returned in several different units. The AUNITS (amplitude units) command is used to select the desired unit. The AUNITS command can either specify a single unit to be used for all power and amplitude information, or it can be set to automatically select the units, based on certain measurement settings. Refer to the description of the AUNITS command in Chapter 5 of this manual for more information.

Parameter versus Measurement Units

All units referred to above are **parameter units** which are standard scientific units. Trace data may optionally be sent to and received from the analyzer in non-standard units, **measurement units**, which are used internally by the analyzer. The main advantage to communicating with the analyzer in measurement units is speed; when the analyzer communicates in parameter units, it must convert between internal measurement units and parameter units.

The TDF (trace data format) command is used to select measurement or parameter units. Traces are stored internally as integers in the range from 0 to 600, where 0 represents the bottom graticule line and 600 represents the top graticule line. Since there are 10 graticule divisions vertically, there will be 60 measurement units per graticule. There is a small over-range area above the top graticule line (up to 610), so traces may contain numbers slightly larger than 600.

To convert from measurement units to parameter units or vice-versa, you must have the following information at the time that the trace data is measured: log-scale setting (dB/division or linear), reference level, and the amplitude units in which the reference level is expressed. For log scales where the reference level is expressed in a dB-related unit, the following formulas may be used:

$$\text{Parameter Units} = \text{Reference Level} + \text{Log Scale} \times \frac{\text{Measurement Units} - 600}{60}$$

$$\text{Measurement Units} = \frac{\text{Parameter Units} - \text{Reference Level}}{\text{Log Scale}} \times 60 + 600$$

If reference level is not expressed in a dB-related unit, it must first be converted to such a unit before using the formulas.

When using a linear display scale, the following formulas may be used with the reference level expressed in volts. If the reference level is not expressed in volts, it must be converted to volts before these formulas are used.

$$\text{Parameter Units} = \text{Reference Level} \times \frac{\text{Measurement Units}}{600}$$

$$\text{Measurement Units} = \frac{\text{Parameter Units}}{\text{Reference Level}} \times 600$$

Notice that the interpretation of measurement units *always* depends on the reference level and amplitude scaling of the display at the time that the trace data was measured.

Position Units and Trace Elements

Traces are comprised of a fixed number of **elements** (601). Each element has a fixed position on the horizontal axis of the trace. An element is identified by specifying its horizontal position in **position units**. Position units are integers, ranging from 1 to 601. The element at the left end of a trace is always identified by a position value of 1. The element at the right end of a trace has a position value of 601.

The left edge of the trace corresponds to the start frequency and the right edge corresponds to the stop frequency. You will need to know start and stop frequencies under which the trace data was measured if you plan to convert from position units to frequency.

Trace-Data Formatting

The TDF (trace-data format) command controls the formatting of trace-amplitude data. The HP 8560A, HP 8561B, and HP 8563A provide five format modes: real-number parameter units (P) format, binary (B) format, A-block format, I-block format, and measurement units (M) format. All the format modes return amplitude information in measurement units except for TDF P, which returns parameter units.

The output format, and how to transfer data to and from a computer with each format, is described below.

TDF P: Return Decimal Numbers in Parameter Units

The real number, or "P" format allows you to receive or send data as ASCII decimal values in real-number (parameter) units. This is the default format when the instrument is powered up, and when instrument preset (IP) is activated. Numbers are in dBm, dBmV, dB μ V, volts, or watts, as determined using the amplitude units (AUNITS) command. Default units are volts for linear trace information, and dBm for logarithmic trace information.

A line feed (ASCII code 10) follows data output. The end-of-identify message (EOI) is sent with a line feed.

Note



When using the P-format, be sure to include amplitude units with the trace data using the AUNITS command.

Real-number data may be an advantage if you wish to use the data later in a program. However, data transfers using P-format tend to be slow and require more storage memory (approximately 1200 bytes for binary and 4800 bytes for real numbers). In some cases, P-format can take up to four times the amount of controller memory compared to binary format.

Example 3 below illustrates how to send trace data to a computer.

EXAMPLE 3

```
10 REAL A(1:601)
20 OUTPUT 718;"IP;CF 300 MHZ;SP 20 MHZ;SNGLS;TS;"
30 CALL Get_settings(Fa,Fb,Rl,Rb,Vb,St,Lg,Aunits$)
40 OUTPUT 718;"TDF P;TRA?"
50 ENTER 718;A(*)
60 END
70 SUB Get_settings(Fa,Fb,Rl,Rb,Vb,St,Lg,Aunits$)
80 OUTPUT 718;"FA?;FB?;RL?;RB?;VB?;ST?;LG?;AUNITS?;"
90 ENTER 718 USING "K";Fa,Fb,Rl,Rb,Vb,St,Lg,Aunits$
100 SUBEND
```

Line 10 dimensions array A to 601 elements (one element for each point of trace data). The array is dimensioned using the REAL statement, allowing each array element to accept real-number data.

Line 20 sets the analyzer to a desired state.

Line 30 calls the subprogram that queries the spectrum analyzer for the required state data.

Line 40 specifies P-format (TDF P), then queries the analyzer for data in trace A (TRA?).

Line 50 enters the data into the array.

Example 4 illustrates how to return data from a computer to the spectrum analyzer.

EXAMPLE 4

```
10 REAL A(1:601)
20 OUTPUT 718;"IP;CF 300 MHZ;SP 20 MHZ;SNGLS;TS;"
30 CALL Get_settings(Fa,Fb,Rl,Rb,Vb,St,Lg,Aunits$)
40 OUTPUT 718;"TDF P;TRA?"
50 ENTER 718;A(*)
60 PRINT "PRESS CONTINUE TO RETURN DATA TO THE ANALYZER"
70 PAUSE
80 OUTPUT 718;"IP;TDF P;VIEW TRA;"
90 CALL Setup_analyzer(Fa,Fb,Rl,Rb,Vb,St,Lg,Aunits$)
100 OUTPUT 718;"TRA ";
110 FOR I=1 TO 600
120 OUTPUT 718;A(I);"DBM,";
130 NEXT I
140 OUTPUT 718;A(601);"DBM;"
150 END
```

Lines 10 to 50 are the same as in Example 3 above.

Line 80 begins to send trace data by presetting the analyzer, preparing the spectrum analyzer to accept data into trace A, and selecting the P-format.

Line 90 sets the analyzer to the stored trace conditions per the subroutine in Example 2.

Lines 100 to 140 enter the stored trace data into trace A. When sending trace data into the analyzer using P-format, the data points must be entered into the analyzer one point at a time. Note that in Line 120 each data point value of the trace array is followed by the amplitude units (in this case, dBm).

TDF M (M-format): Return Decimal Numbers in Measurement Units

(output only)

The measurement units (M) format transfers trace data as ASCII integer values in measurement units, which is the internal format used by the spectrum analyzer. See Figure 4-5. The displayed amplitude of each element falls on one of 601 vertical points (with the 601st equal to the reference level). For example, the peak of the signal in Figure 4-5 is equal to -10 dBm, or one division below the reference level. This is equal to 540 measurement units (600 measurement units at the reference level, less 60 measurement units for one division down, equals 540 measurement units). There are also ten additional points of overrange. Measurement units, then, range from 0 to 610.

A line feed (ASCII code 10) follows data output. The end-of-identify message (EOI) is sent with a line feed.

The M-format is faster than the P-format, but most applications will require computer conversion to parameter units. Also, since the M-format transfers data as ASCII characters, the data may be viewed directly.

To send trace data to the computer, see Example 5.

EXAMPLE 5

```
10  INTEGER A(1:601)
20  OUTPUT 718;"IP;CF 300 MHZ;SP 20 MHZ;SNGLS;TS;"
30  CALL Get_settings(Fa,Fb,RL,Rb,Vb,St,Lg,Aunits$)
40  OUTPUT 718;"TDF M;TRA?;"
50  ENTER 718;A(*)
60  PRINT A(*)
70  END
```

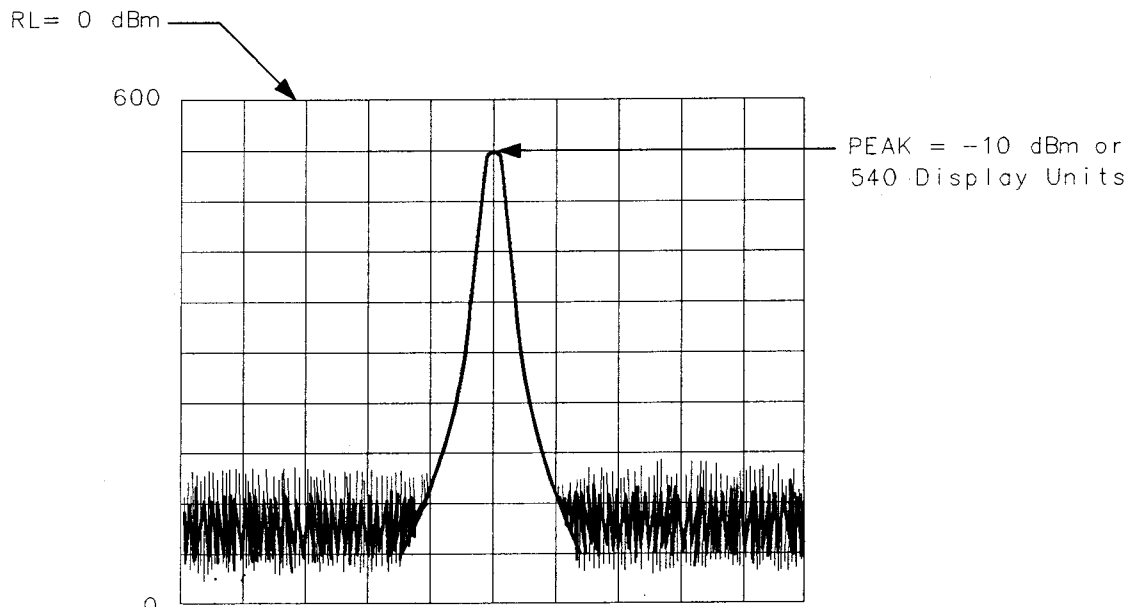

Figure 4-5. Data Transferred in TDF M Format

TDF B (B-Format): Return Binary Numbers in Measurement Units

(output only)

The binary (B) format, transmits data in measurement units, as binary numbers. This format provides the fastest data transfer and requires the least amount of memory to store data. Each data point is transferred in binary as two 8-bit bytes; the most significant byte is sent first, followed by the least significant byte. Binary data can also be easily converted into measurement data. If speed and memory are important considerations, you may prefer B-format to P-format.

Unlike A-block and I-block formats, the B-format does not send a header. The data is sent immediately, and the end-or-identify message (EOI) is sent with the last byte.

Example 6 shows how to transfer data in B-format from the spectrum analyzer to a computer.

EXAMPLE 6

```
10  INTEGER Tra_binary(1:601)
20  ASSIGN @Sa_bin TO 718;FORMAT OFF
30  OUTPUT 718;"IP;CF 300 MHZ;SP 20 MHZ;SNGLS;TS;"
40  CALL Get_settings(Fa,Fb,Rl,Rb,Vb,St,Lg,Aunits$)
50  OUTPUT 718;"TDF B;TRA?"
60  ENTER @Sa_bin;Tra_binary(*)
70  END
```

Line 10 dimensions the array Tra_binary to 601 elements. Here the INTEGER statement dimensions each array element as two bytes (remember, each data point transferred in B-format is sent as two 8-bit bytes).

Line 20 assigns the spectrum analyzer address to "@Sa_bin". Format is set to off because the trace data is transferred in the format of two 8-bit bytes and this format is also the internal format of the computer.

Line 40 enters the instrument state conditions.

Line 50 selects B-format, then queries the spectrum analyzer for trace A data.

Line 60 enters the data into the array Tra_binary.

To convert a trace-data point from binary to a real, logarithmic number (for example, dBm), use the equation below:

$$\begin{aligned}n &= RL - 10 \text{ divisions} \times \text{Log Scale} + \text{Log Scale} \times \left(\frac{x}{600/10 \text{ divisions}} \right) \\ &= RL + \text{Log Scale} \times \left(\frac{x}{600/10 \text{ divisions}} - 10 \text{ divisions} \right)\end{aligned}$$

where: x = binary data in an array element

RL = reference level in dBm, dBmV, or dB μ V

Log Scale = the log scale in units of dB per division selected on the spectrum analyzer.

n = real, log data

Example 7 converts binary values to measurement data and prints them on the computer display.

EXAMPLE 7

```
10  INTEGER Trace_a(1:601)
20  DIM Real_num(1:601)
30  Ref_lvl=0           !0 dBm reference level
40  Log_scale=10       !10dB/division log scale
50  OUTPUT 718;"TDF B;TRA?;"
60  ENTER 718 USING "#,W";Trace_a(*)
70  MAT Real_num= Trace_a
80  FOR X=1 TO 601
90  Real_num(X)=Ref_level+Log_scale*(Real_num(X)/60-10)
100 NEXT X
110 END
```

For converting linear data, use this equation:

$$n = RL \times \left(\frac{x}{600} \right)$$

where: x = binary data in an array element

RL = reference level. When RL is in volts, n will be in volts.

These equations are useful when you are interested in viewing only a few points of data, rather than an entire trace. B-format saves time and memory, and these equations provide a means to view the data, if necessary.

Note



It is not possible to return data to the analyzer using binary format. You must use either A-block or I-block format. These two formats are described below.

TDF A (A-block format): Return Absolute Block-Data Fields in

Measurement Units

The A-block format transmits data in measurement units as binary numbers in an absolute block-data field, or field of a known size, similar to the binary format. Each data point is sent as two 8-bit bytes; the most significant byte is sent first, followed by the least significant byte. The A-block format also transfers a four-byte header before the 601 points of trace data. The bytes are the ASCII characters "#", "A", and a two-byte length field specifying the number of data bytes in the block that follows (that is, 1202). The first two characters indicate that the transferred data is in A-block format. "1202" indicates the length of the trace data, expressed in bytes. As previously mentioned, trace data is composed of 601 trace elements. Each trace element is transferred as one word that is composed of two 8-bit bytes. Thus, 601 words contain 1202 bytes. 1202 is the trace length sent. You may want to keep this format and trace length information separate from the actual trace data, as in Example 8.

The end-of-identify message (EOI) is sent with a line feed.

IP (instrument preset) and device clear select words as the default data size. Block data formats are the fastest method of transferring trace data.

Example 8 illustrates how to keep the format and trace length information separate from the actual trace data.

EXAMPLE 8

```
10  INTEGER Tra_binary(1:601)
20  DIM Header$[4]
30  OUTPUT 718;"IP;CF 300 MHZ;SP 20 MHZ;SNGLS;TS;"
40  CALL Get_settings(Fa,Fb,Rl,Rb,Vb,St,Lg,Aunits$)
50  OUTPUT 718;"TDF A;TRA?;"
60  ENTER 718 USING "#,4A,601(W)";Header$,Tra_binary(*)
70  END
```

Line 10 creates the array Tra_binary using the INTEGER statement.

Line 20 creates a string, Header\$. The header will be placed in this string, separate from the trace data.

Line 50 specifies the data format, then queries for the contents of trace A.

Line 60 places the header in "Header\$" and places 601 points of trace data in "Tra_binary". Header\$ will contain the #A and two non-printing characters that represent in binary the integer 1202. The first non-printing character is CHR\$(4), and the second non-printing character is CHR\$(178). Since this string does not contain desired trace data, you can discard it. The USING statement specifies that four header characters will be transferred, followed by 601 16-bit words, which are the actual trace data. The "#" sign within the USING statement suppresses any end-of-line signals that may occur before the last trace-data byte is sent.

To send trace data from the computer to the analyzer, refer to Example 9.

EXAMPLE 9

```
10  INTEGER Tra_binary(1:601)
20  DIM Header$[4]
30  OUTPUT 718;"IP;CF 300MHZ;SP 20MHZ;SNGLS;TS;"
40  CALL Get_settings(Fa,Fb,Rl,Rb,Vb,St,Lg,Aunits$)
50  OUTPUT 718;"TDF A;TRA?;"
60  ENTER 718 USING "#,4A,601(W)";Header$,Tra_binary(*)
70  PRINT "PRESS CONTINUE TO RETURN DATA TO THE ANALYZER"
80  PAUSE
90  OUTPUT 718;"IP;TS;VIEW TRA;"
100 CALL Setup_analyzer(Fa,Fb,Rl,Rb,Vb,St,Lg,Aunits$)
110 OUTPUT 718;"TDF A;"
120 OUTPUT 718 USING "#,K,W,601(W)";"TRA#A",1202,Tra_binary(*)",";"
130  END
```

Line 90 presets the analyzer and sets trace A to view mode.

Line 100 returns the state data to the analyzer.

Line 110 sets the data format to A-block.

Line 120 sends the TRA command, the format information and the trace data. The USING statement specifies that the data "TRA#A" will be sent as characters, followed by a word (1202) and 601 16-bit words (the actual trace data). Remember, you must send #A to indicate the format and 1202 to indicate the length of the trace, in bytes. The # sign within the USING statement suppresses any end-of-line signal characters.

TDF I (I-block format): Return Indefinite Block-Data Fields in

Measurement Units

Very similar to A-block format, the I-block format transmits data in measurement units as binary numbers in an indefinite block-data field of unknown size. Each data point is sent as two 8-bit bytes; the most significant byte is sent first, followed by the least significant byte. The I-block format also transfers a header before the trace data. The header is comprised of ASCII characters "#", and "I". These characters indicate that the trace data is in I-block format. Like the A-block format examples, when sending the trace data to the computer, you may want to keep these two characters separate from the trace data, as in Example 10.

I-format sends an end-of-identify message (EOI) with the last byte of data. IP (instrument preset) and device clear select words as the default data size. Block data formats are the fastest method of transferring trace data.

Example 10 uses the I-block format to separate the # and I characters from the trace data.

EXAMPLE 10

```
10  INTEGER Tra_binary(1:601)
20  DIM Header$[2]
30  OUTPUT 718;"IP;CF 300MHZ;SP 20 MHZ;SNGLS;TS;"
40  CALL Get_settings(Fa,Fb,Rl,Rb,Vb,St,Lg,Aunits$)
50  OUTPUT 718;"TDF I;TRA?;"
60  ENTER 718 USING "#,2A,601(W)";Header$,Tra_binary(*)
70  END
```

Like the examples for the A-block format, you store format information in a string (Header\$) and store the desired trace data in an integer array (Tra_binary).

Returning the trace data to the analyzer requires an important instruction. The "I" in the term I-block refers to the ability of the spectrum analyzer to accept data of "indefinite" length when using I-block format. Even though the analyzer uses only 601 points of trace data, the I-block format lets you send any number of data points. The spectrum analyzer will continue to accept data until an end-of-instruction (EOI) signal is sent to it. HP 9000 Series 200/300 BASIC allows you to send an EOI with the last data byte using the END command. Refer to Example 11 below.

EXAMPLE 11

```
10  INTEGER Tra_binary(1:601)
20  DIM Header$[2]
30  OUTPUT 718;"IP;CF 300MHZ;SP 20MHZ;SNGLS;TS;"
40  CALL Get_settings(Fa,Fb,Rl,Rb,Vb,St,Lg,Aunits$)
50  OUTPUT 718;"TDF I;TRA?;"
60  ENTER 718 USING "#,2A,601(W)";Header$,Tra_binary(*)
70  PRINT "PRESS CONTINUE TO RETURN DATA TO THE ANALYZER"
80  PAUSE
90  OUTPUT 718;"IP;TS;VIEW TRA;"
100 CALL Setup_analyzer(Fa,Fb,Rl,Rb,Vb,St,Lg,Aunits$)
110 OUTPUT 718;"TDF I;"
120 OUTPUT 718 USING "#,K,601(W)";"TRA#I",Tra_binary(*) END
130 END
```

By now most of this program should look familiar. Line 120 requires some explanation, however. The END statement appearing after the array Tra_binary sends (to the spectrum analyzer) the last data byte stored in the array, with the HP-IB EOI line set "true," as required by I-block format.

Transmission Sequence of Data on HP-IB

Table 4-2 shows an HP-IB transmission sequence for each format mode. Each one transmits the +10 dBm amplitude level of a one-element trace with the amplitude equal to the reference level. In each case, the HP 9000 Series 200 or 300 computer must be instructed how to interpret the data received correctly. The parenthetical numbers in the table are decimal values representing binary 8-bit numbers.

Table 4-2.
HP-IB Transmission Sequence for Different Trace-Data Formats (TDF)

	Byte 1	Byte 2	Byte 3	Byte 4	Byte 5	Byte 6
TDF P	1	0	.	0	0	(10-EOI)
TDF M	6	0	0	(10-EOI)		
TDF A	#	(A)	(0)	(2)	(2)	88-EOI
TDF I	#	(I)	(2)	88-EOI		
TDF B	2	88-EOI				

Input and Output Buffers

Features of the HP 8560A, HP 8561B, and HP 8563A include the input and output data buffers. This section describes how to take advantage of the buffers and how to avoid potential programming pitfalls.

Benefits of an Output Buffer

The 64-character input buffer allows you to send several data queries to the spectrum analyzer using only one OUTPUT statement. The 64-character output-data buffer holds queried values so that you can read them into variables using only one ENTER statement. This is a more efficient method than using one OUTPUT statement per query and one ENTER statement per value read. See Example 1.

EXAMPLE 1

```
10 OUTPUT 718;"IP;SNGLS;MKPX 6DB;MKPT -65DB;FA 270MHZ;FB
1200MHZ;TS;"
20 OUTPUT 718;"MKPK HI;MKD;MKPK NR;MKF?;MKA?;"
30 ENTER 718 USING "K";Mka,Mkf
40 PRINT Mka,Mkf
50 END
```

Example 1 reads the difference in frequency and amplitude between two peaks, then enters the values into variables. Note the order of the queries and entries. The first query is the first value to come out of the output-data buffer; you read the values into variables in the same order that you query the spectrum analyzer.

Whenever you execute a query, be sure to read that value out. If you do not read it out, you will get that value returned for your next query. See Example 2.

EXAMPLE 2

```
10 OUTPUT 718;"CF?;"
20 OUTPUT 718;"AT UP;RL?;"
30 ENTER 718;R1
40 PRINT R1
50 END
```

In Example 2, even though you wanted to read the reference level, the printed value is equal to the center frequency. The center frequency had been left in the output-data buffer and was the first value to come out of the buffer.

If you are entering multiple values into multiple variables with one ENTER statement, use a "K" format with the ENTER statement. The spectrum analyzer separates queried values by a line feed with an end-or-identify (EOI) asserted; "K" format recognizes that a new value starts after each line feed with EOI. If you omit the USING statement, the ENTER statement will terminate on the first EOI encountered and generate an error.

Buffer Space

The maximum number of characters that the output-data buffer can hold is 64. In Example 1, the query MKD? filled seven character spaces in the output-data buffer. The returned value, -33.34, fills six spaces; the line feed that separates this value from the next one fills the seventh space. This method is used to enter all queries into the output-data buffer. You can continue to query the analyzer until the queries fill all 64 spaces. The input buffer fills similarly. The query AT? fills four spaces in the input data buffer. The input buffer can hold as many commands as will fill its 64-character capacity. The returned frequency value is not dependent on the current resolution bandwidth.

Preventing Timeouts

A program can pause unexpectedly when the output data buffer is completely filled with query values, the input buffer is completely filled with commands, and the spectrum analyzer is currently executing a query. Under this set of conditions, the program will pause indefinitely. The spectrum analyzer is trying to complete the query, but there is simply no more room in the output-data buffer for any more query data and no place to hold the query in the input buffer. If you have a timeout statement in the program, a timeout will occur. To prevent this situation, do not allow query values or commands to stack up in the buffers. Query for only a few values, then read them into variables before you send more queries. If you must leave the output buffer full, do not send more than 64 characters of commands with one OUTPUT statement.

A program may also pause unexpectedly while the spectrum analyzer is executing a command that takes a long time to complete. Consider executing the take-sweep (TS) command when the selected sweep time is equal to 100 seconds. In this case, the TS command requires 100 seconds before it is completed. While this command is executing, the input-data buffer fills with 64 characters of commands. When the buffer is full, if there are any remaining commands in that OUTPUT statement, the program will pause. It will start again when the TS command is complete; the spectrum analyzer can then begin processing the commands in the buffer, and the remaining commands in the OUTPUT statement will move into the input data buffer. If you have a timeout statement in your program, the timeout may occur; this depends on whether the timeout setting is shorter than the pause in the program.

Synchronizing Your Program

You can use spectrum analyzer queries to synchronize a program. For example, when executing a TS command, if you want to know when the TS command is complete, execute the DONE command immediately after TS. The DONE query is satisfied only after the sweep has been completed. In fact, you can use any query in this manner. No query operation can take place until after the previous command is complete.

Clearing the Buffers

If you use the output-data buffer correctly, the buffer should be clear after the last ENTER statement is executed. But if you want to ensure that the buffer is empty, execute the device clear statement CLEAR 718. If your program is returning incorrect values,

use this statement to clear the buffer; then look through your program for any missing ENTER statements. Or, use CLEAR at the beginning of a program. CLEAR flushes out the output-data and input-data buffers; however, it also executes an instrument preset.

Summary

Figure 4-6 illustrates the input and output data buffers. Below, the causes for the analyzer not accepting data are highlighted.

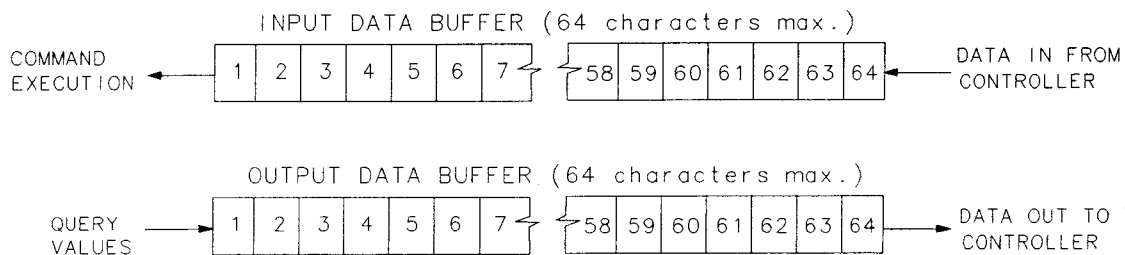

Figure 4-6. Buffer Summary

The spectrum analyzer will stop accepting data under these non-exclusive conditions:

1. A sweep or lengthy command is not done and the input buffer is full.
2. The output and input buffers are full and the command currently executed is a query.

Math Functions

The analyzer processes and stores measurement results that can be displayed or manipulated arithmetically.

This section describes the internal processing of traces and tells how to manipulate data correctly with the math commands.

Variables and Traces

The analyzer processes all information as variables and trace arrays. For example, the analyzer reserves an area in memory for trace A information. Whenever trace A is swept, the analyzer updates that memory area with new data. The analyzer also has space in memory for variables. Whenever a marker is placed on a trace, the analyzer assigns the amplitude value to the variable, MKA (marker amplitude).

Variables

Variables exist permanently in the analyzer memory. The CF (center frequency) command and SP (frequency span) command are examples of variables.

Traces

Traces consist of a series of data points that contain amplitude information. Two separate traces may be swept: trace A or B. These are the pre-defined traces that exist permanently in the analyzer memory. Traces A and B each have preset lengths of 601 data points.

Math Commands

Math commands are data-manipulating functions that modify traces or return modified data to the computer.

Two Rules for Trace Math

Special consideration must be exercised when using math commands with traces. Otherwise, these data-manipulating commands may yield inaccurate results. Follow these two rules to obtain accurate results:

- Avoid truncation of data. Be sure that the destination length is equal to or greater than the source length.
- Remember that the analyzer limits numbers greater than 600 (610 with overrange) and less than 0 (slightly above the top and at the bottom graticule, respectively), when operating with trace elements.

Math operations are restricted to the legal range of measurement units when trace arrays form the destination or source.

Adding and Subtracting in dBm

The HP 8560A, HP 8561B, and HP 8563A trace-math method allows easy addition and subtraction of correction values in dBm units. For example, to correct for 3 dB of loss in trace A data values, you can add or subtract trace B, which has been preloaded with +3 dBm or -3 dBm as its data values. The two traces can then be added or subtracted using APB (trace A plus trace B) or AMB (trace A minus trace B) and thus eliminate the effects of the loss.

Note that in the example above, the result is an addition or subtraction of dBm and not an addition or subtraction of power. Consider a trace-data value of -50 dBm and a second trace-data value of -50 dBm. When the two values are added using the APB command, the result is $-50 \text{ dBm} + -50 \text{ dBm} = -100 \text{ dBm}$. However, if two -50 dBm power sources at two different frequencies are physically summed, the result is a power of -47 dBm. To further illustrate this point, if trace A is at 3.0 dBm and trace B is at 7.0 dBm, performing APB; moves trace A to 10.0 dBm (that is, trace A would move up on the screen). On the other hand, if trace A is at -10 dBm and trace B is at -6.0 dBm, performing APB; drops trace A data to -16 dB, even though trace B is 4.0 dBm higher in power in both cases. As you can see, the spectrum analyzer is not adding and subtracting physical values, but rather providing an efficient method for calculations in dBm units.

Use AMBPL to Correct Data

The AMBPL (trace A minus trace B plus display line) command provides the most versatile method for applying correction data to a trace. AMBPL subtracts the contents of trace B from the contents of trace A and adds the result to the display line. Consider characterizing the response of a device under test in a swept-measurement system. Enter the response of the system in trace B. Insert the device into the system, then enter this response into trace A. Use AMBPL to subtract the system response from the response with the device under test; the result is the response of the device under test, which is centered about the display line. So, to correct data, use trace B to store a copy of the uncorrected response and subtract this from new data in trace A; the result is a corrected response.

If the two traces are identical, as in the following example, the result of subtracting these two traces will equal 0 dBm. Note, however, that if the reference level is less than 0 dBm, the results will be off the screen, or even clipped (clipping is described under "Trace Data Limits" below). The display line is added to return the result to the screen, with no clipping occurring. Since you can specify the position of the display line, you can move the corrected data to any on-screen position.

Example 1 illustrates how to correct data remotely. Before running this example, connect the calibration signal to the INPUT 50Ω.

EXAMPLE 1

```
10  OUTPUT 718;"IP;SNGLS;CF 300MHZ;SP 20KHZ;RB 10KHZ;LG 5DB;TS;"
20  OUTPUT 718;"CLRW TRA; CLRW TRB;TS;"
30  OUTPUT 718;"VIEW TRB;DL -16DBM;"
40  OUTPUT 718;"AMBPL ON;"
50  END
```

Line 10 executes an instrument preset, then uses the calibration signal to simulate uncorrected data. The program sets the reference level to -10 dBm, the span to 20 kHz, the center frequency to 300 MHz, the resolution bandwidth to 10 kHz, the log scale to 5 dB, and the sweep to single mode.

Line 20 sets traces A and B to clear-write mode and takes data into both traces.

Line 30 sets trace B to view mode in order to freeze the data in this trace. Use the display line to indicate where you want the corrected data to appear on the screen; for this example, the display line is set to -16 dBm.

Line 40 executes the function AMBPL. Trace B is subtracted from trace A; since the traces are identical, the result is a flat response equal to 0 dBm. Note, however, that the reference level is at -10 dBm; if this were the end of the calculation, you would not be able to see the result. The display line is added to move the response to -16 dBm and onto the screen where you can view the result.

Adding and Subtracting in Volts

In linear mode, all trace math is executed in positive-voltage units. This means that the APB command moves trace A data up the screen, while the AMB command moves trace A data down the screen (assuming trace B contains non-zero data).

To illustrate the difference between trace math in log mode and in linear mode, see Example 2. Here, both trace A and trace B are set to mid-screen values. When in log mode, the result of executing "AMB ON" appears at the top of the screen. When in linear mode, the result appears at the bottom of the screen.

EXAMPLE 2

```
10  ! PUT TRACES ON SCREEN
20  INTEGER Atrace(1:601)
30  FOR I=1 TO 601
40  Atrace(I)=300
50  NEXT I
60  OUTPUT 718;"IP;LG 10DB;SNGLS;TS;"
70  OUTPUT 718 USING "#,K,W,601(W) ,K";"TDF
A;TRA#A",1202,Atrace(*),";"
80  OUTPUT 718 USING "#,K,W,601(W) ,K";"TDF
A;TRB#A",1202,Atrace(*),";"
90  OUTPUT 718;"AMB ON;"
100 PRINT "PRESS CONTINUE"
110 PAUSE
120 OUTPUT 718;"LN;SNGLS;TS;"
130 OUTPUT 718 USING "#,K,W,601(W) ,K";"TDF
A;TRA#A",1202,Atrace(*),";"
140 OUTPUT 718 USING "#,K,W,601(W) ,K";"TDF
A;TRB#A",1202,Atrace(*),";"
150 OUTPUT 718;"AMB ON;"
160 PAUSE
170 END
```

Trace Data Limits

The displayed amplitude of each trace element falls in one of 601 vertical data points. See Figure 4-7. There are an additional 10 points of overrange. The spectrum analyzer clips results that exceed these limits. The overrange is equal to one-sixth of a division above the reference level. Also, the same clipping algorithm is applied to correction data in a trace (for example, correction data that you enter into trace B). For example, if the reference level is 0 dBm the scale is equal to 10 dB per division, the correction values must be within the range of +1.66 dBm to -100.00 dBm (one-sixth of 10 dB is equal to 1.66 dB).

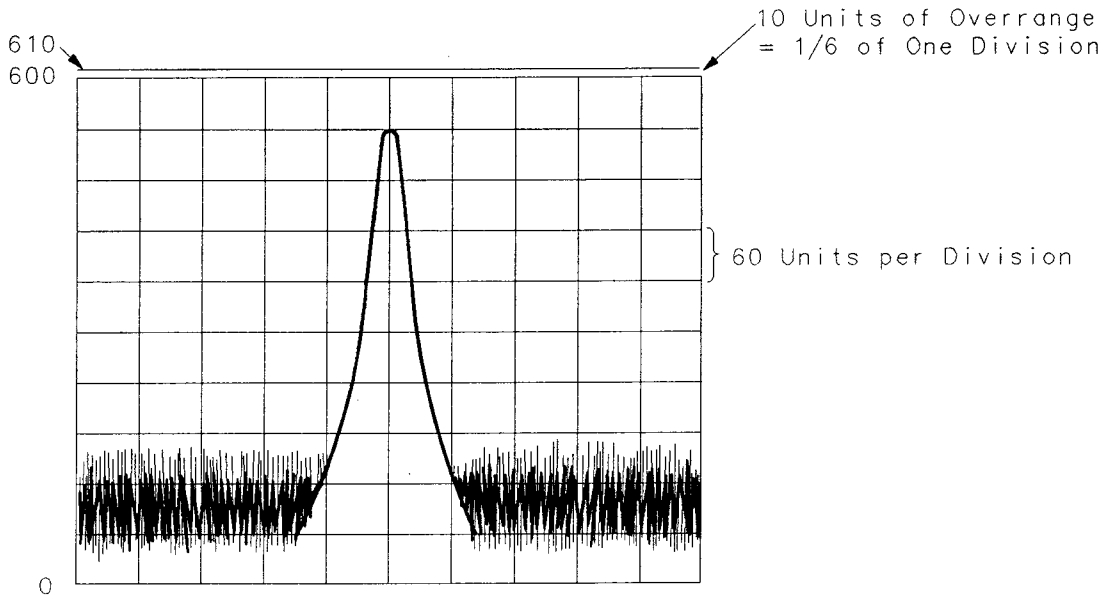

Figure 4-7. Display Units

Creating Screen Titles

Screen titles allow you to label instrument data as shown in Figure 4-8. They can help identify on-screen data or data that you want to store or print. The HP 8560A, HP 8561B, and HP 8563A have commands to create titles remotely, and several methods can be used to make titles. These include using no format, or using A-block or I-block format. Each method is described below.

Note also that the first 16 characters of a title become the label for a stored instrument state or stored trace. The label replaces the register number of the state or trace that usually appears on the spectrum analyzer menu. If you save or recall states or traces remotely, be sure to use the register number and not this label.

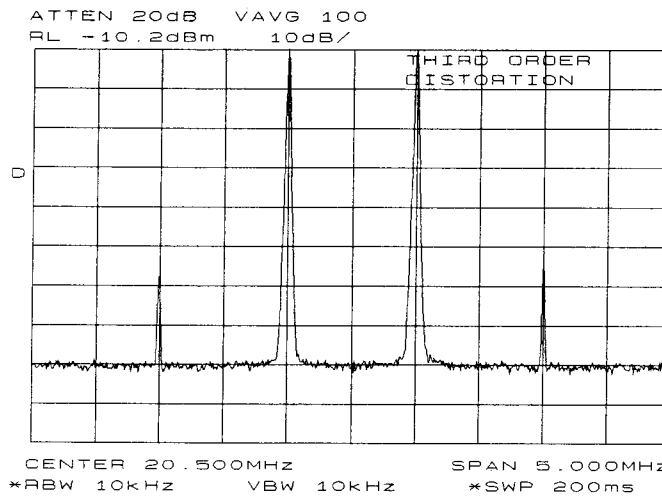

Figure 4-8. Screen Titles Appear in the Upper-Right Corner of the Graticule

No-Format Method

This is the simplest method for creating a title. No format is used; you simply enclose the title within string delimiters. (A list of delimiters appears below.) Refer to Example 1.

EXAMPLE 1

```
10 OUTPUT 718;"TITLE@This is a title@"  
20 END
```

In this example, the "@" symbols are the string delimiters. Inside the delimiters is the title. A title can be up to 32 characters in length. On the spectrum analyzer display, a title appears on up to two lines of 16 characters each. The title can be made up of any valid, printing ASCII characters (line feed and carriage return are not recommended).

The list of string delimiters are: ! \$ % & ' / : = @ \ | < > { }

Format Methods

The method described above allows you to enter a title directly. Using formats provides greater flexibility. You can use data that has been previously stored in a string as the title. This data can be in ASCII characters, or even in binary or decimal equivalents. The two formats, A-block and I-block, are described below.

Making a Title in A-Block Format

A-block format allows you to use a string of data as a title. A-block format also requires that this string be of a known length; the length is sent to the spectrum analyzer. To place the title in a string, see Example 2.

EXAMPLE 2

```
10 DIM A$[15]
20 A$="THIS IS A TITLE"
```

A-block format also requires that you send the length of the title, in bytes. When using Hewlett-Packard BASIC (HPBASIC), this task is easily accomplished. See Example 3.

EXAMPLE 3

```
10 DIM A$[15]
20 A$="THIS IS A TITLE"
30 OUTPUT 718 USING "#,K,W,K";"TITLE#A",LEN(A$),A$,";"
40 END
```

Line 30 sends the TITLE command to the analyzer: the #A to specify that the title is in A-block format; the string length; and the contents of the string, which is the actual title. The USING statement specifies that some of the data will be sent as characters (K) and some as a 16-bit word (W). The character data is the spectrum analyzer command (TITLE #A) and the title (in A\$). The length of the trace (LEN(A\$)) is sent as one 16-bit word that is made up of two 8-bit bytes. The # sign in the USING statement suppresses any end-of-line characters.

Making a Title in I-Block Format

I-block format, like A-block format, also allows you to use string data as a title. With I-block, however, you can send a string of indefinite length. The spectrum analyzer will continue to accept data (up to 32 characters) until an end-or-identify (EOI) signal is sent to the spectrum analyzer. See Example 4.

EXAMPLE 4

```
10 DIM A$[15]
20 A$="THIS IS A TITLE"
30 OUTPUT 718 USING "#,K";"TITLE#I",A$,END
40 END
```

This example is much like the previous one. For I-block format, you must place the title in a string. However, you do not send the title length. Line 30 sends all character data; thus, the USING statement specifies K format only. TITLE #I activates the analyzer TITLE function and specifies that the title is in I-block format. A\$ sends the title, and the END statement, which is sent with the last byte of title data, activates the end-or-identify control line. Again, the # sign in the USING statement suppresses any end-of-line characters.

Generating Plots and Prints Remotely

In addition to the plot and print functions available from the spectrum analyzer front panel, the HP 8560A, HP 8561B, and HP 8563A also allow you to generate plots and prints remotely. This section describes how to combine plot commands to generate plots, as well as the print command to generate a color or monochrome print.

Plotter Requirements

Be sure your plotter satisfies the following requirements to execute the programming examples in this section successfully.

1. The following plotters are supported: the HP 7470A, HP 7475A, HP 7550A and the HP 7440A ColorPro. Be sure that the HP 7550A Plotter is in "standard" mode.
2. Set the plotter to address 5 and cycle the power. To change the address on the plotter, refer to the plotter's operation manual. If you want to use a different plotter address for remote operation, be sure to modify the examples accordingly. Remember, to generate plots from the spectrum analyzer front panel, you must reset the address to 5.

Note

The plotter should *not* be set to LISTEN ALWAYS mode.



The plotter address of 5 corresponds to the default plotter address that the analyzer uses. This default can be changed via **PLOTTER ADDRESS** under the **CONFIG** key.

3. Know how to select the scaling points on your plotter. The scaling points (referred to as the P1 and P2 plotter coordinates) define the lower-left and upper-right corners of the plot. See Figure 4-9. These coordinates define the size of the plot. Table 4-3 shows the scaling points for several Hewlett-Packard plotters.

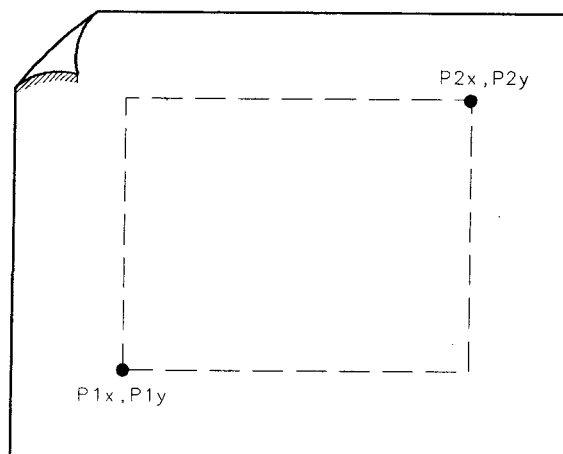

Figure 4-9. P1 and P2 Coordinates

Table 4-3. Scaling Points for Various Plotters

Plotter	Typical Scaling Points		Plotting Range	
	P1x,P1y	P2x,P2y	X-Axis	Y-Axis
HP 7440	200,200	7400,11000	0 to 7544	-39800 to +51000
HP 7475A	250,279	10250,7479	0 to 10300	0 to 7650

Making a Basic Plot

To make a basic plot, choose P1 and P2 coordinates for the plot size you desire and set the plotter to these values. The typical coordinates shown in Table 4-3 create a plot with approximately 1" margins on an 8-1/2" x 11" sheet of paper. (Many plotters have default values for this size of paper.) You can enter coordinates in a program directly, or query the plotter for the values. The latter method is used in the example program below. To generate a plot, connect the plotter via HP-IB to the computer and execute Example 1.

EXAMPLE 1

```

10  OUTPUT 705;"OP;"
20  ENTER 705; P1x,P1y,P2x,P2y
30  OUTPUT 718;"PLOT ";P1x;" ";P1y;" ";P2x;" ";P2y;" ";
40  SEND 7;UNL LISTEN 5 TALK 18 DATA
50  END

```

Line 10 queries the plotter for its P1 and P2 coordinates.

Line 20 enters the P1 and P2 coordinate values into variables.

Line 30 sends the spectrum analyzer PLOT command and the plotter coordinates.

Line 40 sends the following statements over the HP-IB interface: UNL sets all instruments on the HP-IB to unlisten mode; LISTEN 5 sets only the plotter to listen mode; TALK 18 specifies the spectrum analyzer as the talker, which can then send its display contents to the plotter. Since the controller's HP-IB interface must not interfere with the plot, the DATA statement puts the controller HP-IB interface on standby and sets the attention line low.

Example 1 illustrates the statements required to generate a plot. However, there is no provision to indicate to the controller when the plot is finished. Example 2 uses a spectrum analyzer "command complete" service request to indicate when the plot is done. (Service requests are discussed later in this chapter.) When the spectrum analyzer PLOT command is finished, a "command complete" service request is triggered and signals that the plot is done.

EXAMPLE 2

```

10  OUTPUT 705;"OP;"
20  ENTER 705;P1x,P1y,P2x,P2y
30  ON INTR 7 GOTO Done
40  ENABLE INTR 7;2
50  OUTPUT 718;"RQS 16;"
60  OUTPUT 718;"PLOT ";P1x;" ";P1y;" ";P2x;" ";P2y;" ";
70  SEND 7;UNL LISTEN 5 TALK 18 DATA
80  Idle:  GOTO Idle
90  Done:  S_poll=SPOLL(718)
100 OUTPUT 718;"RQS 0;"

```

```

110 PRINT "COMMAND IS COMPLETE"
120 END

```

Lines 10 and 20 obtain the P1 and P2 coordinates, as in the previous example.

Line 30 commands the controller to go to the subroutine Done when an interrupt occurs.

Line 40 enables the controller to receive service request interrupts.

Line 50 The RQS command specifies that a "command complete" condition will generate a service request.

Lines 60 and 70 plot the display contents.

Line 80 keeps the controller on Line 80 of the program until the plot is finished and the PLOT command satisfies the "command complete" condition. When the plot is finished, the controller continues to the subroutine Done. Done performs a serial poll on the spectrum analyzer and reads the generated service request. This also clears the analyzer of this request.

Line 100 returns the spectrum analyzer service requests to their initial condition.

Line 110 prints on the computer screen that the plot is done.

Plotting Options

Perhaps you do not want the entire display contents transferred to the plotter. You may want to plot only a trace, or only a trace and the screen annotation. The spectrum analyzer PLOTSRC (plot source) command specifies the display contents you want to plot. Choose to plot the entire display, trace A, trace B, the annotation, or the graticule. Example 3 illustrates how to plot trace A and the annotation.

EXAMPLE 3

```

10  OUTPUT 705;"OP;"
20  ENTER 705;P1x,P1y,P2x,P2y
30  OUTPUT 718;"PLOTSRC TRA;RQS 16;PLOT
    ";P1x;",",P1y;",",P2x;",",P2y";RQS 0;"
40  GOSUB Wait_plot
50  OUTPUT 718;"PLOTSRC ANNT;RQS 16;PLOT
    ";P1x;",",P1y;",",P2x;",",P2y";RQS 0;"
60  GOSUB Wait_plot
70  PRINT "COMMAND IS COMPLETE"
80  STOP
90  Wait_plot:  ON INTR 7 GOTO Go_back
100             ENABLE INTR 7;2
110             SEND 7;UNL LISTEN 5 TALK 18 DATA
120  Idle:     GOTO Idle
130  Go_back:   S_poll=SPOLL(718)
140             RETURN
150  END

```

Another available plot function, the PLOTORG (display origins) command, specifies whether the plotter P1 and P2 coordinates are the origins for the entire analyzer display or for its

graticule. If you choose the graticule as the origin and plot only the graticule, you can, in effect, create graph paper especially for analyzer plots. Using paper with preprinted graticule lines can save plotting time. When you use this paper, be sure to set the PLOTORG command in reference to the graticule ("PLOTORG GRT") and use the P1 and P2 coordinates that you used to create the graticule lines.

Printer Requirements

Be sure your printer satisfies the following requirements to execute the programming examples in this section successfully.

1. HP-IB printers with graphics capability are supported (for example, the HP 2225A ThinkJet and the HP 3630A PaintJet).
2. Set the printer to address 1 and cycle the power. If you cannot locate the address switch on the printer, refer to the printer's operation manual. If you want to use a different printer address for remote operation, be sure to modify the examples accordingly. Remember, to generate prints from the spectrum analyzer front panel, you must reset the address to 1.

Note



The printer address of 1 corresponds to the default printer address that the analyzer uses. This default can be changed via **PRINTER ADDRESS** under the **CONFIG** key.

Making a Basic Print

To make a basic print, use any HP-IB printer with graphics capability. If using a color printer, the color format (PRINT 1) can be selected; otherwise, a monochrome output is the default output selected. The example program shown below demonstrates how to generate a print.

Note



The color format output cannot be selected for use with a monochrome printer (for example, an HP ThinkJet).

```
10  OUTPUT 718;"IP;"
20  OUTPUT 718;"CF 300MHZ;SP 1MHZ;TS;DONE?;"
30  ENTER 718;Done
40  ON INTR 7 GOTO Finish
50  ENABLE INTR 7;2
60  OUTPUT 718;"PRINT 0;RQS 16;"
70  SEND 7;UNT UNL LISTEN 1 TALK 18 DATA
80  Idle:  GOTO Idle
90  Finish: S_poll=SPOLL(718)
100         OUTPUT 718;"RQS 0;"
110 PRINT "PRINT IS COMPLETE"
120 END
```

Monitoring System Operation

The programming techniques discussed so far describe communication between the analyzer and the computer, where the sequence of all data transfer is controlled by a computer program. This section describes how the analyzer can interrupt computer operation when the analyzer has attained a particular state.

The interrupting process is called a service request. Service requests have many applications. They facilitate economical use of computer-processing time when the analyzer is part of a large measurement system. For example, after the computer initiates an analyzer measurement, the computer can make calculations or control other devices via HP-IB while the analyzer is measuring. When the analyzer is through, it signals the computer with a service request. The computer's service-request subprogram then determines what the computer will do next. Service requests can also be used to report analyzer errors and other analyzer events, such as end-of-sweep.

Interrupt Process

The interrupt process begins when the analyzer "requests" attention by setting the HP-IB service-request line (SRQ) true. The computer must be programmed to respond to this event. Typically, the computer is programmed to interrupt normal program execution and call a user-specified subroutine when the service request occurs. If multiple instruments are being controlled remotely, this subroutine determines which instrument(s) on HP-IB caused the service request. Then, it may be necessary to call another subroutine which determines why a particular instrument requested service (since there may be more than one possible cause). Finally, a subroutine(s) will be called to respond to the indicated event(s). Note that more than one instrument may request service simultaneously, and each instrument may have more than one event to report. These steps are summarized below.

1. Computer monitors HP-IB service request line (SRQ).
2. Analyzer requests service by setting the SRQ line true.
3. Computer branches to routine that determines the instrument(s) that caused the SRQ.
4. Computer branches to routine that determines why a particular instrument is requesting service.
5. Computer branches to routine to process a specific event in a particular instrument.

Some of the routines above may be omitted, if only one instrument has been instructed to use the SRQ line, or if a particular instrument has been instructed to use the SRQ line for only one event.

Several system-level statements are required to make the computer respond to service requests. The HP BASIC statement, `ENABLE INTR` (enable interrupt), tells the computer to monitor the service-request line. The on-interrupt statement, `ON INTR`, specifies where the computer program will branch when a service request occurs. If more than one instrument could cause the service request, or if an instrument can cause a service request for more than one reason, the serial-poll statement, `SPOLL`, is used. The serial-poll statement is always required to clear the service request being generated by the instrument.

Analyzer Status Byte

The analyzer **status byte** indicates the status or occurrence of certain analyzer functions. The status byte contains eight bits, numbered 0—7, with bit 0 being the least significant bit.

Bits 0, 1, 2, 3, 4, 5, and 7 represent specific conditions or events. These bits are referred to as **condition bits** and **event bits**. Condition bits reflect a condition in the analyzer which may be present or absent at any given moment. Event bits reflect the occurrence of a transition or event within the analyzer.

Bit 6 is set by the analyzer to indicate whether or not it is requesting service.

When the analyzer is instructed not to use the service request line on HP-IB, the status bits always reflect the current condition of the analyzer. In this situation, the *event bits* in the status byte should not be used. Event bits are only true at the exact instant of a transition in the analyzer and as such are not reliable when service requests are disabled.

When the analyzer is instructed to generate service requests for one or more conditions or events, the status bits reflect the current condition of the analyzer until a service request is generated. Then, the bits which are generating the service request are held true until the status byte is read out of the analyzer (by the HP BASIC SPOLL system-level statement), by the STB? command, or until an HP-IB DEVICE CLEAR (HP BASIC CLEAR system-level statement) is received. These actions clear the status byte to once again reflect the current conditions and events within the analyzer.

The Service-Request Mask

The service-request mode is enabled and controlled by the request-service-condition command, RQS. It defines a **service-request mask** that specifies which of the status-byte bits may generate a service request. Below, RQS specifies the ERROR-PRESENT and COMMAND-COMPLETE states (bits 5 and 4, respectively) for service requests.

```
OUTPUT 718;"RQS ";DVAL("00110000",2)
```

Selects bit 5 and 4 (32+16) to enable service request mode for ERROR-PRESENT and COMMAND-COMPLETE.

```
OUTPUT 718;"RQS 48;"
```

Also selects bits 5 and 4 as above, but is somewhat easier to read.

Once RQS is executed, the analyzer requests service by setting the SRQ line true when the desired conditions or events occur.

Table 4-4. Status Register

Bit Number	Decimal Equivalent	Analyzer State	Description
7	128		Not used
6	64	RQS	Requests Service
5	32	ERROR PRESENT	Set when error present
4	16	COMMAND COMPLETE	Any command is completed
3	8		Not used
2	4	END OF SWEEP	Set when any sweep is completed
1	2	MESSAGE	Set when display message appears
0	1	TRIGGER	Trigger is activated

Computer Interrupt Statements

Now that the spectrum analyzer is prepared to trigger service requests, you must prepare the computer to accept this type of interrupt. Use the BASIC statements ON INTR ... GOTO or CALL or GOSUB and ENABLE INTR. ON INTR ... GOTO causes the computer to branch to a subroutine or some other part of the program when an interrupt is generated. ENABLE INTR enables the computer to accept an interrupt. These two commands appear below.

```
10 OUTPUT 718;"RQS 16;"
20 ON INTR 7 GOSUB Srq
30 ENABLE INTR 7;2
```

In this example, Line 20 indicates that if an interrupt appears (ON INTR 7), the computer is to go to the subroutine Srq (GOSUB Srq). The 7 specifies the interface select code; in this case, it refers to the Hewlett-Packard Interface Bus (HP-IB). Line 30 enables the computer to accept an interrupt. Here, the 7 again specifies the HP-IB select code. The semicolon is part of the BASIC statement ENABLE INTR. The 2 indicates that the interrupt is specifically a service request interrupt, which is asserted from the SRQ line of the HP-IB. From Line 10, you know the interrupt will be a service request triggered from a "command complete" condition.

Now that the spectrum analyzer and computer can assert and accept service-request interrupts, choose an event that will trigger the service request and create a subroutine to handle the interrupt. In the example below, the take sweep command (TS) is used to trigger a command complete signal. (Since ten video-averaging sweeps are desired, this signal does not occur until after the selected number of averages is complete.) This service request will cause the computer to go to the subroutine Srq. The subroutine identifies the type of service request and prints it on the computer screen. See Example 1, below.

EXAMPLE 1

```
10 OUTPUT 718;"IP;SNGLS;CF 300MHZ;SP 20MHZ;TS;"
20 OUTPUT 718;"VAVG 10;RQS 16;"
30 ON INTR 7 GOSUB Srq
40 ENABLE INTR 7;2
50 OUTPUT 718;"TS;"
60 Srq: Sbyte=SPOLL(718)
70 PRINT Sbyte
80 PRINT "VIDEO AVERAGING IS COMPLETE"
90 OUTPUT 718;"RQS 0;"
100 END
```

Line 10 sets the desired instrument state. Note that the instrument is set to single-sweep mode. This allows the video averages to happen only when the take-sweep command is sent.

Line 20 selects the number of video averages desired. It is not until after the VAVG (video average) command is sent that the RQS command is sent. This ensures that no previous commands can accidentally generate an SRQ.

Line 30 indicates to go to the routine Srq when an interrupt occurs.

Line 40 enables the computer to accept the interrupt.

Line 50 sends the take-sweep command; during the 10 video averages that will now occur, the computer remains on line 60. When the video averaging is complete, TS is complete and the "command complete" condition is satisfied. The computer then branches to the subroutine Srq.

Line 70 causes the computer to read the decimal equivalent of the generated service request into the variable Sbyte. The computer then prints the value, alerting you that the interrupt has occurred.

Line 100 returns the status register to its initial state (that is, no conditions are masked).

Reading Service Request Data

In the above example, you used the serial-poll statement (SPOLL) to read the service request data into a variable. The STB (Status Byte Query) command also reads service request data. Example 2 shows how.

EXAMPLE 2

```
10  OUTPUT 718;"IP;SNGLS;CF 300MHZ;SP 20MHZ;TS;"
20  OUTPUT 718;"VAVG 10;RQS 16;"
30  ON INTR 7 GOSUB Srq
40  ENABLE INTR 7;2
50  Done=0
60  OUTPUT 718;"TS;"
70  Idle:  IF Done=0 GOTO Idle
80          STOP
90  Srq:OUTPUT 718;"STB?";
100 ENTER 718;Sbyte
110 PRINT Sbyte
120 PRINT "VIDEO AVERAGING IS COMPLETE"
130 OUTPUT 718;"RQS 0;"
140 Done=1
150 RETURN
160 END
```

Line 20 sets the bit mask so that only the "command complete" condition is set. On Line 70, once the "command complete" condition is satisfied (in this case, after ten video averages), the STB command queries the spectrum analyzer for the service-request data. The data is then entered into variable Sbyte and printed. The value returned is the decimal equivalent of the generated service request.

Reading Service Requests From More Than One Instrument

Most instruments that can be controlled remotely have service request capability similar to that in the HP 8560A, HP 8561B, and HP 8563A. You may want to take advantage of this capability in other instruments as well as in the spectrum analyzer. If you have more than one instrument on a bus than can generate a service request, you need to modify the above program to look for interrupts from more than one instrument. See Example 3.

EXAMPLE 3

```
10  OUTPUT 718;"IP;SNGLS;CF 300MHZ;SP 20MHZ;TS;"
20  OUTPUT 718;"VAVG 10;RQS 16;"
30  ON INTR 7 GOSUB Srq
40  ENABLE INTR 7;2
50  Done=0
60  OUTPUT 718;"TS;"
70  Idle: IF Done=0 GOTO Idle
80  STOP
90  Srq: Sbyte_1=SPOLL(718)
100  Sbyte_2=SPOLL(705)
110  IF BIT (Sbyte_1,6)=1 THEN
120  PRINT "SERVICE REQUEST",Sbyte_1,"ON ADDRESS 18"
130  OUTPUT 718;"RQS 0;"
140  STOP
150  END IF
160  IF BIT(Sbyte_2,6)=1 THEN
170  PRINT "SERVICE REQUEST",Sbyte_2,"ON ADDRESS 5"
180  END IF
190  ENABLE INTR 7;2
200  Done=1
210  RETURN
220  END
```

In this example, you execute the SPOLL command for each instrument that may cause a service request interrupt; in this case, the analyzer or an instrument that is set to address 5. Once the instruments are queried for interrupts, the IF ... THEN statements provide a way to branch to the appropriate routine.

Testing Service Request Routines

In the previous programming examples, you knew that a service request would be generated when the VAVG command was completed. You could easily test the program and make sure that it worked. However, service requests may not always be so predictable; this can make a program difficult to test. The spectrum analyzer SRQ command automatically triggers any service request you choose. Of course, as with other service requests, you must set the bit mask before executing the SRQ command. See Example 4.

EXAMPLE 4

```
10  OUTPUT 718;"IP;SNGLS;CF 300MHZ;SP 20MHZ;TS;"
20  OUTPUT 718;"RQS 16;"
30  ON INTR 7 GOSUB Srq
40  ENABLE INTR 7;2
50  Done=0
60  OUTPUT 718;"SRQ 16;"
70  Idle:  IF Done=0 GOTO Idle
80          STOP
90  Srq:   Sbyte=SPOLL(718)
100         PRINT Sbyte
110         PRINT "INTERRUPT GENERATED"
120         OUTPUT 718;"RQS 0;"
130         Done=1
140         RETURN
150         END
```

Here, on Line 50, a "command complete" service request is immediately generated, and you can be sure that the routine will work.

Summary

The main points to using service requests are highlighted below.

1. Choose the conditions for generating service requests.
2. Set a bit mask that enables only these chosen conditions.
3. Prepare the computer to accept service requests. Use the ON INTR ... GOSUB and ENABLE INTR statements.
4. Once an interrupt is triggered, use the analyzer STB command or the SPOLL statement to read the interrupt.

Language Reference

Introduction

This chapter contains complete information for the programming commands available to operate an HP 8560A, HP 8561B, and HP 8563A Spectrum Analyzers. The topics covered in this chapter are listed below.

- **Syntax diagram conventions** describes the pictorial notation that represents the proper syntax for each command. Refer to Table 5-1 for definitions of syntax elements.
- **Secondary keywords** lists the valid secondary keywords. See Table 5-2.
- **Programming codes** lists the programming commands by functional groups.
- **Programming commands** are listed in alphabetical order according to their mnemonic, followed by a complete description of their syntax, parameters, and function.

For your convenience, three cross-reference listings for the HP 8560A, HP 8561B, and HP 8563A Spectrum Analyzers are supplied in the Appendixes.

Appendix B, Softkey Cross Reference, is an alphabetical listing of all softkeys with the corresponding front-panel key under which the softkey is located.

Appendix C, Key versus Programming Command Cross Reference, is an alphabetical listing of all front-panel keys and softkeys with their corresponding remote command.

Appendix D, Programming Command versus Key, is an alphabetical listing of all valid spectrum-analyzer remote commands with their corresponding front-panel keys or softkeys (if applicable).

Syntax Diagram Conventions

Pictorial Notation

- All items enclosed by an oval are literals and must be entered exactly as shown.
- Items enclosed by a rectangular box indicate parameters used in the command sequence. A description of each parameter is given in the respective command description.
- Command sequence items are connected by lines. Each line can be followed in only one direction, as indicated by an arrow at the end of each line.
- Any combination of command sequence items that can be generated by following the lines in the proper direction is syntactically correct.
- A command sequence item is optional if there is a valid path around it.

Command Sequence

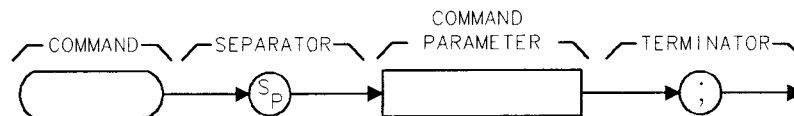

A typical command sequence is represented above. The order of command sequence items is specified in the syntax diagram for each respective command. “Command Sequence Summary” provides a description of the syntax elements in the sequence shown above.

Command Sequence Summary

command	Any valid command. Commands are literals and must be entered exactly as shown.
separator	Separators are required to separate command sequences and command sequence items. The separators allowed for the spectrum analyzer are as follows: S _P (space) , (comma)
command parameter	Any secondary key word recognized by the command.

terminator

A terminator is required to end all command sequences. The terminators allowed for the spectrum analyzer are as follows:

- ; (semicolon)
- LF (line feed)
- CR (carriage return)
- SP (space)
- ,

Query Responses

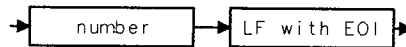

Figure 5-1. Numeric Value Query Response

Commands which set a function to a numeric value can be queried to determine the current setting of that function. For example, the CF command sets the center frequency to a numeric value in hertz. The format for the response to a CF query command is shown above. Refer to Table 5-1 for definitions of syntax elements.

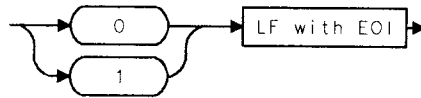
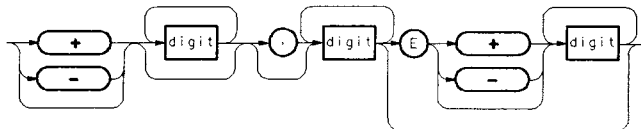

Figure 5-2. Binary State Query Response

Other commands which control the binary state of a function can also be queried to determine its state. Examples are commands which accept ON and OFF parameters such as the ANNOT or GRAT commands. The query response in this case, as shown above, is either zero (indicating that the queried state is off or inactive) or one (indicating that the queried state is on or active). As an example, GRAT? will return a zero if the display graticule is off, and a one if it is on.

Table 5-1. Syntax Elements

Component	Description
data byte	8-bit byte containing numeric or character data.
data byte & EOI	8-bit byte containing numeric or character data sent with end-or-identify (EOI).
delimiter	<p data-bbox="480 522 883 546">! \$ % & ' / : = \ @ & ^ _ ` ~</p> <p data-bbox="480 556 1360 709">A character, chosen from the above list, marks the beginning and end of a string of characters. For simplified use, choose delimiters that are <i>not</i> the same as any character within the string they delimit. Otherwise, every occurrence of the delimiter character inside the string being delimited must be replaced with a <i>pair</i> of delimiters when forming the delimited string.</p>
digit	0 1 2 3 4 5 6 7 8 9
LF with EOI	Line feed (LF) with end-or-identify (EOI). ASCII code 10 (line feed) is sent with EOI control line.
number	<p data-bbox="480 984 1117 1008">Expressed in integer, decimal, or exponential (E) form.</p> <p data-bbox="521 1031 914 1054">Range: -10^{+100} through $+10^{+100}$</p> <p data-bbox="521 1064 1360 1186">The smallest positive fractional number which may be represented is $+10^{-100}$. This is the range of numbers which may be used in commands. This range is further restricted when numbers are attached to specific types of units:</p> <ul data-bbox="480 1209 1149 1297" style="list-style-type: none"> ■ frequency values are limited to ± 1000 GHz. ■ amplitude values are limited to ± 300 dBm or ± 300 dB. ■ power values are limited to ± 300 dBm or ± 300 dB. <p data-bbox="521 1320 1360 1379">The above ranges may be further limited by hardware. These limitations are identified under the individual command descriptions.</p> <p data-bbox="521 1402 1360 1461">Precision: approximately 15 decimal digits, unless otherwise limited by hardware.</p> <p data-bbox="521 1514 1247 1537">Length: the complete number must be less than 25 characters.</p>



Secondary Keywords

Table 5-2. Secondary Keyword Summary

A	ampere (unit); A-block data format; external mixer frequency band
AC	alternating current (coupling)
ALL	all (marker off, plot screen)
AM	amplitude modulation (DEMOD)
ANNT	annotation
AUTO	automatic operation
B	8-bit byte output format
CURR	current (IF adjustment)
D	external mixer frequency band
DC	direct current (coupling)
DB	relative decibel (unit)
DBM	absolute decibel milliwatt (unit)
DBMV	absolute decibel millivolt (unit)
DBUV	absolute decibel microvolt (unit)
DM	absolute decibel milliwatt (unit)
DN	decrement the parameter
DSP	display
E	external mixer frequency band
EP	enable parameter for front panel operator entry (see note below)
EXT	external (reference, mixer mode)
F	external mixer frequency band
FAV	frequency analog voltage (0.5 V/GHz)
FLATTOP	FFT window format
FM	frequency modulation (DEMOD)
FREE	free run
FULL	full band span width
G	external mixer frequency band
GHZ	gigahertz (unit)
GRT	graticule
GZ	gigahertz (unit)
HANNING	FFT window format
HARM	harmonic number (frequency diagnostic)
HI	highest
HZ	hertz

Note



After executing a command with EP as a secondary keyword, select a numeric value using the spectrum analyzer DATA keys, STEP keys, or knob. When using the data keys, be sure to terminate the value with a units key (such as Hz, dBm, and so on.). When using the step keys or the knob, terminate the value with HOLD.

Table 5-2. Secondary Keyword Summary (continued)

I	I-block data format
INT	internal (reference, mixer mode)
J	external mixer frequency band
K	external mixer frequency band
KHZ	kilohertz (unit)
KZ	kilohertz (unit)
LAST	previous state before a change
LAST SPAN	previous span before a change
LINE	line, as in line trigger
LO	local oscillator (frequency diagnostic)
M	ASCII display data output format
MA	milliamp (unit)
MAN	manual operation
MHZ	megahertz (unit)
MS	millisecond (unit)
MSEC	millisecond (unit)
MROLL	main roller oscillator (frequency diagnostic)
MV	millivolt (unit)
MW	milliwatt (unit)
MZ	megahertz (unit)
NEG	negative peak detection
NH	next highest
NL	next left
NR	next right
NRM	normal rosenfell detection
OA	function query (same as "?")
OFF	turn function off
ON	turn function on
OROLL	offset roller oscillator (frequency diagnostic)
P	real number output format
POS	positive peak detection
PRE	preselected external mixer mode
PWRON	sets same state as turning power on
Q	external mixer frequency band
RAMP	sweep ramp voltage (LO SWP)
S	second (unit)
SA	spectrum analyzer (sweep time coupling)
SC	second (unit)
SEC	second (unit)
SMP	sample detection, sampling oscillator (frequency diagnostic)
SR	stimulus response (sweep time coupling)
TRA	trace A
TRB	trace B

Table 5-2. Secondary Keyword Summary (continued)

U	external mixer frequency band
UA	microamp (unit)
UNIFORM	FFT window format
UNPR	unpreselected external mixer mode
UP	increment the parameter
UV	microvolt (unit)
US	microsecond (unit)
V	volt (unit); external mixer frequency band
VID	video
W	watt (unit); external mixer frequency band
XROLL	transfer roller oscillator (frequency diagnostic)
Y	external mixer frequency band
ZERO	zero span
0	off
1	on
?	returns a query response containing the value or state of the associated parameter (same as OA)

Programming Codes (functional index)

Alternate commands common to the HP 8560A, HP 8561B, and HP 8563A and the HP 8566/8568 are shown in parentheses (). For further information, see "Backward-Compatible Commands" in Appendix F.

Amplitude Control

AT	Specifies input attenuation.
AT AUTO	Couples input attenuation (CA).
AUNITS	Specifies amplitude units for input, output, and display.
COUPLE	Selects ac or dc input coupling.
LG	Selects log scale.
LN	Selects linear scale.
MKRL	Moves active marker amplitude to reference level (E4).
ML	Specifies mixer level.
RL	Specifies reference level.
RLCAL	Calibrates reference level.
ROFFSET	Specifies reference-level offset.

Bandwidth Control

RB	Specifies resolution bandwidth.
RB AUTO	Couples resolution bandwidth (CR).
RBR	Specifies the coupling ratio of resolution bandwidth and frequency span.
VB	Specifies video bandwidth.
VB AUTO	Couples video bandwidth (CV).
VBR	Specifies coupling ratio of video bandwidth and resolution bandwidth.

Coupling Control

AUTOCP	Auto-couple all controls.
AT AUTO	Auto-couple the RF attenuator (CA).
RB AUTO	Auto-couple resolution bandwidth (CR).
SS AUTO	Auto-couple center-frequency step-size (CS).
ST AUTO	Auto-couple sweep time (CT).
VB AUTO	Auto-couple video bandwidth (CV).
RBR	Specifies coupling ratio of resolution bandwidth and frequency span.
VBR	Specifies coupling ratio of video bandwidth and resolution bandwidth.

Demodulation

DEMOMD	Demodulation.
DEMOMDAGC	Demodulation auto gain control.
DEMOMDT	Demodulation time.
SQUELCH	Squelch control for demodulation.

Display Control

ANNOI	Turns annotation on or off. Preset condition is on.
AUNITS	Specifies amplitude units for input, output, and display.
DL	Specifies display-line level in dBm.
DLE	Turns display line on and off (L0).
FDSF	Turns all frequency display annotation off. Preset is the only way to turn it back on.
GRAT	Turns graticule on or off. Preset condition is on.
LG	Selects log scale.
LN	Selects linear scale.
TH	Specifies display threshold value.
TITLE	Writes specified ASCII characters in title block area of display.

External Mixing

CNVLOSS	Sets reference-level offset to compensate for external mixer conversion loss.
EXTMXR	Selects either preselected or unpreselected external mixing mode.
FULBAND	Sets start and stop frequencies for full waveguide bands.
HNLOCK	Locks to specified harmonic number.
HNUNLK	Unlocks the specified harmonic number.
IDCF	Sets center frequency to frequency of SIGID.
IDFREQ	Returns frequency of identified signal.
MBIAS	Specifies the bias level for external mixers.
MKPX	Specifies minimum excursion for peak identification.
MXRMODE	Specifies either internal or external mixing.
SIGID	Identifies signals for external mixing frequency bands.

Frequency Control

CF	Specifies center frequency.
SS AUTO	Couples center-frequency step-size (CS).
FA	Specifies start frequency.
FB	Specifies stop frequency.
FOFFSET	Specifies frequency offset.
FREF	Specifies the frequency reference source.
FS	Specifies full frequency span as defined by instrument state.
FULBAND	Sets the start and stop frequency for full waveguide band (external mixing only).
MKFCR	Specifies resolution of frequency counter.
SP	Specifies frequency span.
SS	Specifies center-frequency step-size.

Information and Service Diagnostics

ADJALL	Initiates power-on adjustment sequence.
ADJCRT	Initiates CRT adjustment patterns.
ADJIF	Initiates IF adjustment sequence.
ERR?	Returns list of instrument error codes.
ET?	Returns elapsed time.
FDIAG	Returns frequency of specified oscillator.
ID?	Returns the HP model number of analyzer used (HP 8560A, HP 8561B, or HP 8563A).
PSDAC	Adjusts or returns preselector-peak DAC number.
REV?	Returns analyzer firmware revision date (YYMMDD format).
RLCAL	Calibrates reference level.
SER?	Returns analyzer serial number.

Instrument State Control

IP	Sets instrument parameters to preset values.
RCLS	Recalls previously saved state (RC).
PSTATE	Protect saved states (save lock).
SAVES	Saves current state of the analyzer in the specified register (SV).

Marker Control

MKA	Amplitude of active marker (MA).
MKCF	Enters marker frequency into center frequency (E2).
MKD	Moves delta marker to specified frequency (M3).
MKDR	Marker delta reciprocal, readout in time.
MKF	Frequency of active marker (MF).
MKFC	Counts marker frequency for greater resolution (see MKFCR).
MKFCR	Specifies resolution of marker frequency counter.
MKMIN	Moves marker to minimum signal detected.
MKN	Moves marker to specified frequency or center screen (M2).
MKNOISE	Average noise value at marker and normalize to 1 Hz bandwidth.
MKOFF	Turns the active marker off (M1).
MKPK	Moves marker to signal peak (E1).
MKPT	Specifies marker peak threshold.
MKPX	Specifies minimum excursion for peak identification. Default value is 6 dB.
MKRL	Moves active marker to reference level (E4).
MKSP	Moves marker delta frequency into span.
MKSS	Moves marker frequency to center-frequency step-size (E3).
MKT	Positions marker at point corresponding to the time from beginning of sweep.
MKTRACK	Turns marker signal track on (MT1) or off (MT0).

Operator Entry

HD Holds or disables data entry and blanks active function CRT readout.

Output Format Control

AUNITS Specifies amplitude units for input, output, and display.
MKA? Returns marker amplitude (MA).
MKF? Returns marker frequency (MF).
SWPOUT Specifies the sweep output.
TRA? Outputs trace A (TA).
TRB? Outputs trace B (TB).
TDF Selects trace data output format as real number parameter units (P) format, binary (B) format, A-block format, I-block format, and measurement units (M) format.

Plotter and Printer Output

OP Returns the display lower-left and upper-right coordinates.
PLOT Sends analyzer display to a plotter.
PLOTORG Scaling points for plot.
PLOTSRC Specifies plot source.
PRINT Sends analyzer display to a printer.

Preselector Control

PP Peaks preselector.
PSDAC Preselector peak data.

Service Request

RQS Specifies the decimal weighting of status byte bits which are allowed during service request. Set to 0 with power-up or device clear.
SRQ Sets service request if operand bits are allowed by RQS.
STB Returns the decimal equivalent of the bits set in the status byte.

Bit	Decimal	Definition
7	—	Not used
6	64	Request service
5	32	Error present in error register
4	16	Command complete
3	—	Not used
2	4	End of sweep
1	2	Message occurred
0	0	Cleared

Sweep and Trigger Control

CONTS	Selects continuous sweep mode (S1).
ST	Specifies sweep time.
ST AUTO	Couples sweep time.
SNGLS	Selects single sweep mode (S2).
TM	Selects trigger mode: free run (T1), video (T4), line (T2), external (T3).
TS	Takes a sweep.
VTL	Video trigger level.

Synchronization

TS	Takes a sweep.
DONE?	Returns a 1 when task has been completed.

Trace Functions

Processing

BLANK	Stores and blanks specified trace register (A4 B4).
CLRW	Clear-writes specified trace register (A1 B1).
MINH	Holds the minimum trace register values.
MXMH	Max-holds the specified trace register (A2 B2).
RCLT	Recall specified trace data.
SAVET	Save specified trace data.
TRA	Input/output trace A.
TRB	Input/output trace B.
VIEW	Views specified trace register (A3 B3).

Math

AMB	$A - B$ into A (C1 C2).
AMBPL	$A - B + DL$ into A.
APB	$A + B$ into A.
AXB	Exchanges A and B (EX).
BML	$B - DL$ into B (BL).
VAVG	Turns video averaging on or off.

Other

AUNITS	Specifies amplitude units for input, output, and display.
DET	Specifies video detector type.

Tracking Generator Control

NORMLIZE	Activates normalization routine.
NRL	Sets the normalized reference level.
NRPOS	Adjusts the normalized reference position.
RCLOSCAL	Recalls stored open/short trace calibration data.
RCLTHRU	Recalls stored thru calibration data.
RL	Adjusts the range level.
SRCALC	Selects internal or external leveling.
SRCCRSTK	Course tunes the tracking generator oscillator.
SRCFINTK	Fine tunes the tracking generator oscillator.
SRCPOFS	Offsets displayed tracking-generator source power.
SRCPSTP	Sets the step size of the source power level.
SRCPSWP	Controls the power-sweep function.
SRCPWR	Controls the output power of the tracking generator.
SRCTKPK	Peaks the tracking generator response.
STOREOPEN	Saves open-input calibration data for use with STORESHORT.
STORESHORT	Averages shorted-input and open-input calibration data and saves the average.
STORETHRU	Stores thru-calibration data.
SWPCPL	Selects a stimulus response or spectrum analyzer coupled sweep time.

User Measurements

ACPBW	Sets the channel bandwidth for an adjacent channel power measurement.
ACPCOMPUTE	Performs an adjacent channel power computation with user instrument settings.
ACPGRAPH	Turns on or off the adjacent channel power graph mode.
ACPLOWER?	Returns the lower adjacent channel power result.
ACPMAX?	Returns the maximum adjacent channel power result.
ACPMEAS	Performs an automatic adjacent channel power measurement.
ACPPWRTX?	Returns the total power transmitted in an adjacent channel power measurement.
ACPSP	Sets the channel spacing for an adjacent channel power measurement.
ACPUPPER?	Returns the upper adjacent channel power result.
FFT	Performs a discrete Fourier transform.
PWRBW	Returns the bandwidth equal to a percentage of total power.
TWNDOW	Creates a trace array for the FFT function.

Programming Commands

This chapter contains the HP 8560A, HP 8561B, and HP 8563A Spectrum Analyzer programming commands. Each spectrum analyzer command is described here. Before using this part of the manual, you may want to refer to Chapter 4 of this manual.

ACPBW Adjacent Channel Power Bandwidth

Syntax

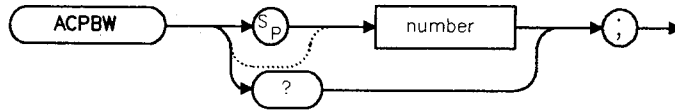

XACPBW

Description

The ACPBW command sets the bandwidth of the channels as an active function for the ACPMEAS and ACPCOMPUTE commands. The channel bandwidth cannot be greater than the channel spacing. If the channel bandwidth is greater than the channel spacing, the spacing is automatically increased. Checking for proper limits is performed in the measurement algorithm. The query returns the channel bandwidth in frequency units.

Query Response

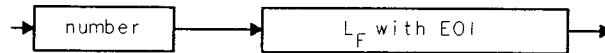

QACP

Example

```

10 REAL Channelbw
20 Cbw = 8.5E6
30 OUTPUT 718;"ACPBW";Channelbw;"
40 END

```

ACPCOMPUTE

Compute Adjacent Channel Power

Syntax

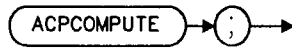

XACPCO

Description

The ACPCOMPUTE command performs the adjacent channel power measurement on the designated signal without changing any instrument state settings. The following three error messages may be observed when using this softkey:

- ERR 908 BW>>SPCG indicates that the channel bandwidth is too wide, compared to the channel spacing, for a valid computation.
- ERR 909 SPAN<ACP indicates that the frequency span is too narrow to obtain a valid measurement.
- ERR 910 SPAN>ACP indicates that the frequency span is too wide, compared to the channel bandwidth, to obtain an accurate measurement.

If any of the three errors occur, the measurement is not completed. To correct the measurement, adjust your instrument state settings depending on the error that has occurred.

Example

```
10 OUTPUT 718;"ACPCOMPUTE;"
```

ACPGRAPH Adjacent Channel Power Graph

Syntax

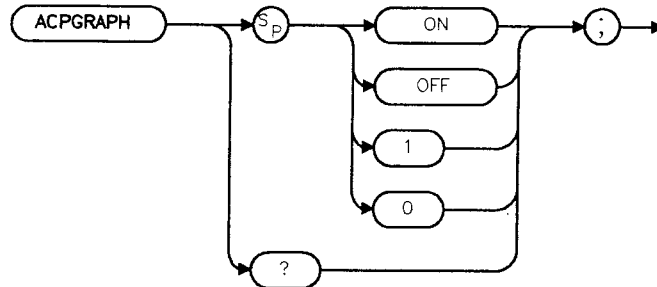

XACPGR

Description

The ACPGRAPH command turns on or off a graphical representation of the adjacent power channel power ratio, for the selected channel bandwidth, as a function of the channel spacing. The upper graticule represents an ACP ratio of 0 dB. The vertical scale for the ACP graph is the same as the vertical scale for the spectrum trace, usually 10 dB/division. The horizontal scale represents the channel spacing, with 0 Hz spacing in the center and a scale factor that is the same as that for the spectrum trace, or the frequency span divided by 10 divisions.

The graph can demonstrate how rapidly the ACP ratio changes with channel spacing. The ACP graph is not defined for channel spacings where the graph is drawn at the bottom graticule line. For these points, the channel bandwidth would include frequencies beyond the edges of the screen, where no data was taken.

Preset State

Off

Query Response

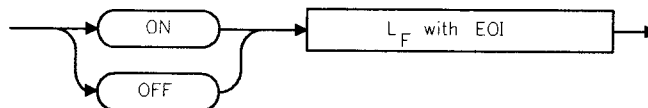

QACPGR

Example

```
10 OUTPUT 718;"ACPGRAPH ON;"
```

ACPLOWER

Lower Adjacent Channel Power

Syntax

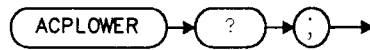

XACPLO

Description

The ACPLOWER query command returns the lower channel power ratio result of the adjacent channel power measurement.

Query Response

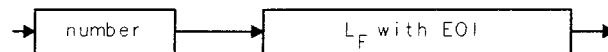

QACP

Example

```
10 OUTPUT 718;"ACPLOWER?;"
```

ACPMAX Maximum Adjacent Channel Power

Syntax

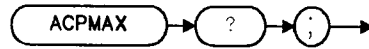

XACPM

Description

The ACPMAX query command returns the maximum adjacent channel power of the adjacent channel power measurement.

Query Response



QACP

Example

```
10 OUTPUT 718;"ACPMAX?;"
```

ACPMEAS

Measure Adjacent Channel Power

Syntax

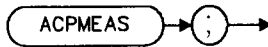

XACPMS

Description

The ACPMEAS command performs an automatic adjacent channel power measurement of a transmitter which determines the leakage power in the adjacent channels from the carrier. The result is the ratio of the leakage power in the adjacent channel to the total power transmitted by the transmitter. ACPMEAS changes the instrument state to optimize the measurement. The instrument state parameters that can be affected are frequency span, resolution bandwidth, video bandwidth, and detection mode. Trace math and video averaging, if on, are turned off.

The results generated by ACPMEAS are categorized as follows and can be queried using the respective query command shown:

- lower channel power (ACPLLOWER)
- upper channel power (ACPUPPER)
- total power transmitted (ACPPWRTX)
- maximum adjacent channel power (ACPMAX)

The current channel spacing and channel bandwidth values are also displayed as follows:

- channel spacing (ACPSP)
- channel bandwidth (ACPBW)

Example

```
10 REAL Lower,Upper,Total_pwr,Max_acp
20 OUTPUT 718;"ACPMEAS;"
30 OUTPUT 718;"ACPLLOWER?;"
40 ENTER 718;Lower
50 OUTPUT 718;"ACPUPPER?;"
60 ENTER 718;Upper
70 OUTPUT 718;"ACPPWRTX?;"
80 ENTER 718;Total_pwr
90 OUTPUT 718;"ACPMAX?;"
100 ENTER 718;Max_acp
110 PRINT USING "K,K";"ACPUPPER= ",Upper
120 PRINT USING "K,K";"ACPLLOWER= ",Lower
130 PRINT USING "K,K";"ACPPWRTX= ",Total_pwr
140 PRINT USING "K,K";"ACPMAX= ",Max_acp
150 END
```

ACPPWRTX Total Power Transmitted

Syntax

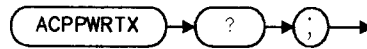

XACPPR

Description

The ACPPWRTX query command returns the result of the total power transmitted calculation of the adjacent channel power measurement.

Query Response

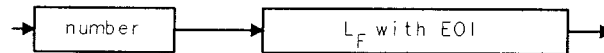

QACP

Example

```
10 OUTPUT 718;"ACPPWRTX?;"
```

ACPSP

Adjacent Channel Power Spacing

Syntax

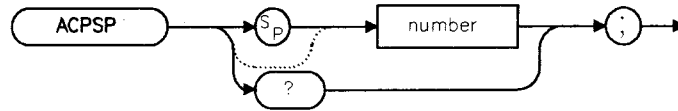

XACPSP

Description

The ACPSP command sets channel spacing as the active function for the ACPMEAS and ACPCOMPUTE commands. The spacing is set between a minimum of 100 Hz to a maximum of 50 GHz. This setting can also be affected by the bandwidth setting. The channel bandwidth cannot be more than the channel spacing. If the channel bandwidth is set more than the channel spacing, the channel spacing is automatically increased. The query returns the channel spacing in frequency units.

Query Response

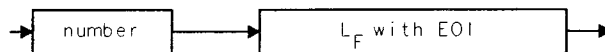

QACP

Example

```
10 REAL Channelsp
20 Csp = 12.5E6
30 OUTPUT 718;"ACPSP";Channelsp;";"
40 END
```

ACPUPPER Upper Adjacent Channel Power

Syntax

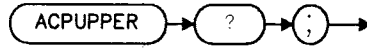

XACPUP

Description

The ACPUPPER query command returns the upper channel power ratio of the adjacent channel power measurement.

Query Response

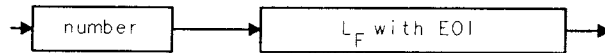

QACP

Example

```
10 OUTPUT 718;"ACPUPPER?;"
```

ADJALL

LO and IF Adjustments

Syntax

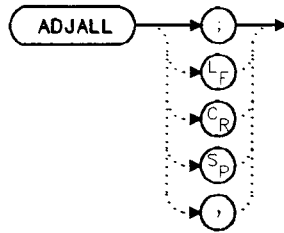

Description

The ADJALL command activates the RF local oscillator (LO) and intermediate frequency (IF) alignment routines. These are the same routines that occur when **LINE** is switched on. Commands following ADJALL are not executed until after the analyzer has finished the alignment routines.

Example

```
10  OUTPUT 718;"ADJALL;"
20  END
```

ADJCRT Adjust CRT Alignment

Syntax

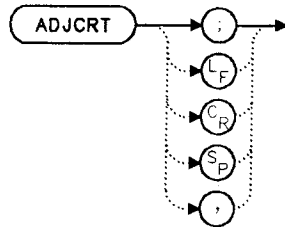

Description

The ADJCRT command activates a CRT adjustment pattern, shown in Figure 5-3. Use the X POSN, Y POSN, and TRACE ALIGN adjustments (available from the rear panel) to align the display. Use X POSN and Y POSN to move the display horizontally and vertically, respectively. Use TRACE ALIGN to straighten a tilted display. To remove the pattern from the screen, execute the IP command.

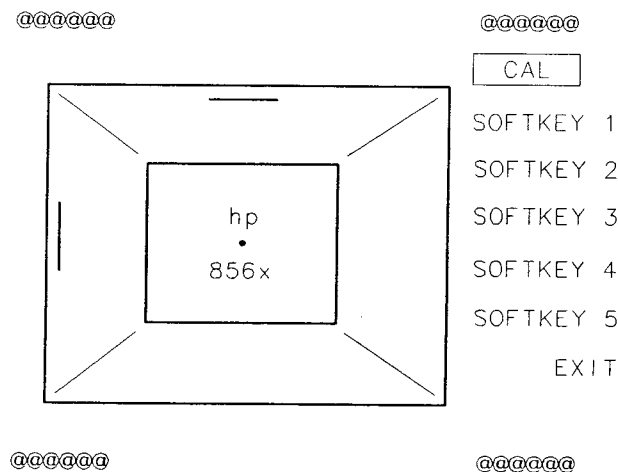

Figure 5-3. CRT Alignment Pattern

Example

```

10  OUTPUT 718;"ADJCRT;"
20  OUTPUT 2;CHR$(255)&"K";
30  PRINT TABXY(0,1);"USE X POSN AND Y POSN"
40  PRINT TABXY(0,3);"TO ADJUST THE DISPLAY"
50  INPUT "THEN PRESS ENTER",Ans$
60  OUTPUT 718;"IP;"
70  END

```

ADJIF

Adjust IF

Syntax

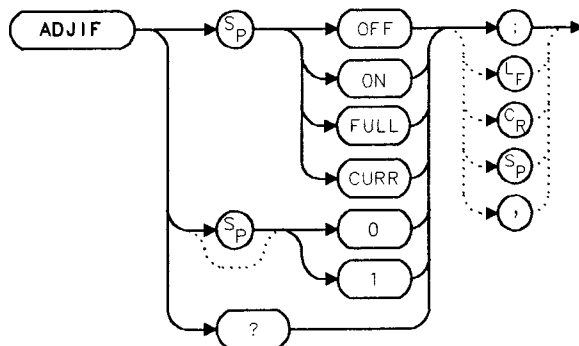

Description

The ADJIF command turns the automatic IF adjustment on or off. This function is normally on. Because the IF is continuously adjusting, executing the IF alignment routine is seldom necessary. When the IF adjustment is not active, an "A" appears on the left side of the display.

Parameters

- FULL IF adjustment is done for all IF settings.
- CURR IF adjustment is done only for the IF settings currently displayed.
- OFF turns the continuous IF adjustment off.
- ON reactivates the continuous IF adjustment.

Preset State

On

Query Response

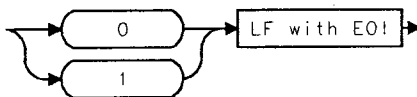

Example

```
10  OUTPUT 718;"ADJIF OFF;"
20  OUTPUT 718;"ADJIF?;"
30  ENTER 718;Adjif
40  PRINT Adjif
50  END
```

AMB

Trace A Minus Trace B

Syntax

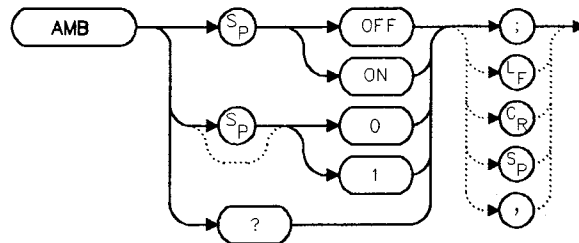

Description

The AMB command subtracts the contents of trace B from trace A and places the result, in dBm (when in log mode), in trace A. When in linear mode, the result is in volts. If trace A is in clear-write or max-hold mode, this function is continuous. When AMB is active, an "M" appears on the left side of the display. The command AMBPL overrides AMB. For more information on trace math, refer to Chapter 4.

Note



The displayed amplitude of each trace element falls in one of 600 data points. There are 10 points of overrange, which corresponds to one-sixth of a division of overrange. When adding or subtracting trace data, any results exceeding this limit are clipped at the limit.

Preset State

Off

Query Response

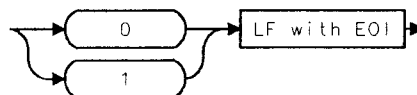

Example

```

10  OUTPUT 718;"IP;"
20  OUTPUT 718;"CLRW TRB;TS;VIEW TRB;AMB ON;"
30  OUTPUT 718;"AMB?;"
40  ENTER 718;Amb
50  PRINT Amb
60  END
  
```

AMBPL

Trace A Minus Trace B Plus Display Line

Syntax

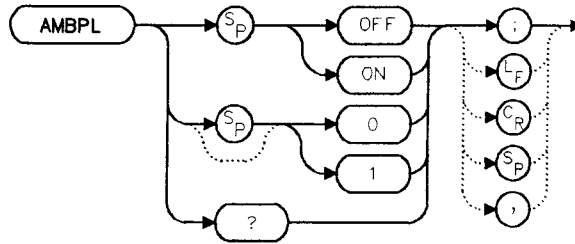

Description

The AMBPL command subtracts the contents of trace B from trace A, adds the display line to this value, and stores the result in dBm (when in log mode) in trace A. When in linear mode, the result is in volts. If trace A is in clear-write or max-hold mode, this function is continuous. When this function is active, an "M" appears on the left side of the display. AMBPL overrides the AMB command.

Note



The displayed amplitude of each trace element falls in one of 600 data points. There are 10 points of overrange, which corresponds to one-sixth of a division of overrange. When adding or subtracting trace data, any results exceeding this limit are clipped at the limit.

Preset State

Off

Query Response

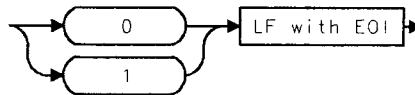

AMBPL Trace A Minus Trace B Plus Display Line

Example

```
10  OUTPUT 718;"IP;"
20  OUTPUT 718;"CLRW TRB;TS;VIEW TRB;DL -50DBM;"
30  OUTPUT 718;"AMBPL ON;"
40  OUTPUT 718;"AMBPL?;"
50  ENTER 718;Ambpl
60  PRINT Ambpl
70  END
```

ANNOT Annotation On/Off

Syntax

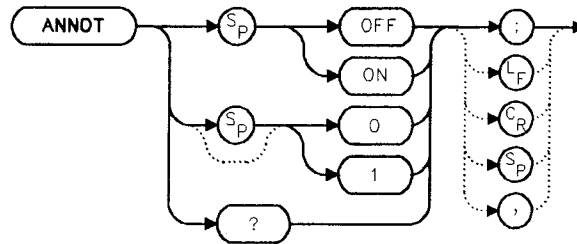

Description

The ANNOT command turns the display annotation off or on.

Preset State

On

Query Response

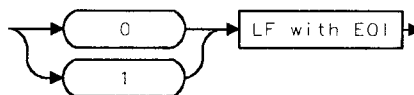

Example

```

10  OUTPUT 718;"IP;"
20  OUTPUT 718;"ANNOT OFF;"
30  OUTPUT 718;"ANNOT?;"
40  ENTER 718;Annot
50  PRINT Annot
60  END
  
```

APB Trace A Plus Trace B

Syntax

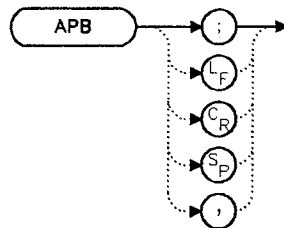

Description

The APB command adds the contents of trace A to trace B and stores the result in dBm (when in log mode), in trace A. When in linear mode, the results are in volts. Trace A is placed in view mode. This command is done immediately and not on a repetitive basis.

Note



The displayed amplitude of each trace element falls in one of 600 data points. There are 10 points of overrange, which corresponds to one-sixth of a division of overrange. When adding or subtracting trace data, any results exceeding this limit are clipped at the limit.

Example

```
10  OUTPUT 718;"IP;SNGLS;"
20  OUTPUT 718;"TS;VIEW TRA;CLRW TRB;TS;VIEW TRB;"
30  OUTPUT 718;"APB;BLANK TRB;"
40  END
```

AT Input Attenuation

Syntax

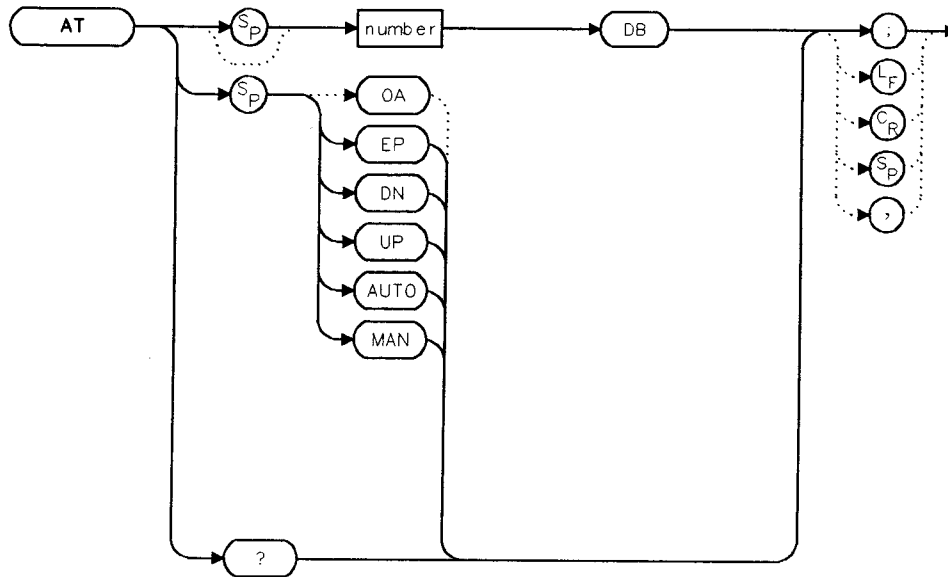

Description

The AT command sets the amount of attenuation between the input and the first mixer.

The attenuation may be set to 0 dB only by numeric data entry, and not by using the knob or step keys.

Parameters

- number** integer from 0 to 70, in decade increments. Numbers are rounded up to the nearest decade.
- AUTO** sets the attenuation to coupled mode.
- MAN** sets the attenuation to manual mode.
- UP/DN** changes the attenuation by 10 dB (but cannot set attenuation to 0 db).

Preset State

Coupled mode, 10 dB

AT Input Attenuation

Query Response



Example

```
10 OUTPUT 718;"AT UP;"
20 OUTPUT 718;"AT?;"
30 ENTER 718;At
40 PRINT At
50 END
```

AUNITS Absolute Amplitude Units

Syntax

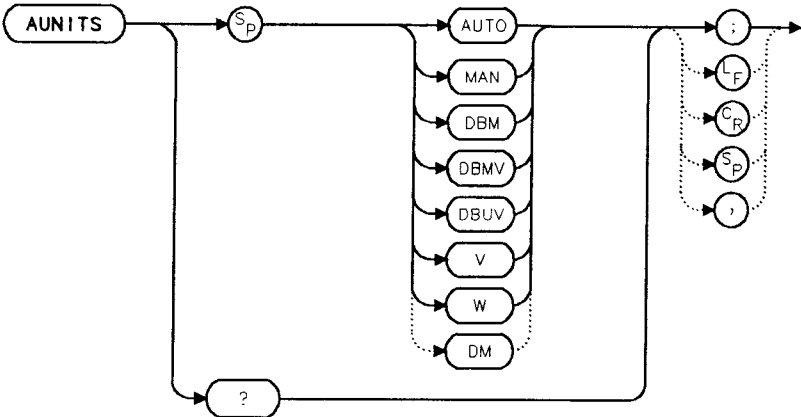

Description

The AUNITS command sets the absolute amplitude units for the input signal and the display. AUNITS will affect the query responses of the following commands: MKA, TRA/TRB (when in P-format), DL, RL, SQUELCH, TH, and VTL. AUNITS is disabled when the HP 8560A Option 002 tracking generator is in use.

Parameters

- AUTO sets amplitude units to coupled mode. For a log scale, the units default to dBm; for a linear scale, units default to volts.
- MAN sets amplitude units to manual mode.

Preset State

Coupled mode, dBm

AUNITS Absolute Amplitude Units

Query Response

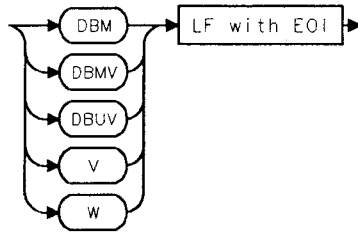

Example

```
10 OUTPUT 718;"AUNITS DBUV;"
20 OUTPUT 718;"AUNITS?;"
30 ENTER 718;Aunits$
40 END
```

AUTOCP Auto Coupled

Syntax

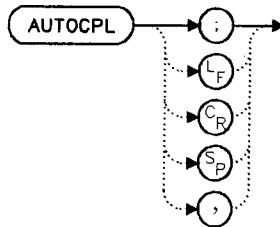

Description

The AUTOCP command sets video bandwidth, resolution bandwidth, input attenuation, sweep time, and center frequency step-size to coupled mode. These functions can be recoupled individually or all at once. The spectrum analyzer chooses appropriate values for these functions. The video bandwidth and resolution bandwidth are set according to the coupled ratios stored under the softkeys **VBW/RBW** or **RBW/SPAN**, or the ratios selected using the VBR or RBR commands. If no ratios are chosen, default ratios (1.0 and 0.011, respectively) are used instead.

Example

```

10  OUTPUT 718;"AUTOCP;"
20  END

```

AXB

Trace A Exchange Trace B

Syntax

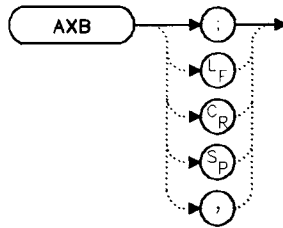

Description

The AXB command exchanges the contents of trace A with those of trace B. If the traces are in clear-write or max-hold mode, the mode is changed to view. Otherwise, the traces remain in their initial mode.

Example

```
10  OUTPUT 718;"AXB;"  
20  END
```

BLANK

Blank Trace

Syntax

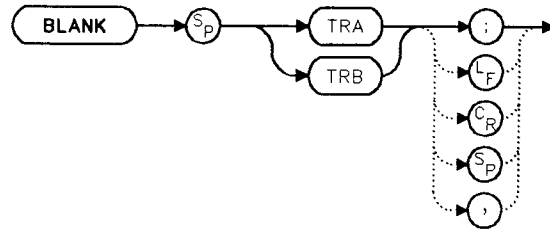

Description

The BLANK command blanks the chosen trace from the display. The current contents of the trace remain in the trace but are not updated.

Example

```
10  OUTPUT 718;"BLANK TRA;"
20  OUTPUT 718;"CLRW TRB;"
20  END
```

BML

Trace B Minus Display Line

Syntax

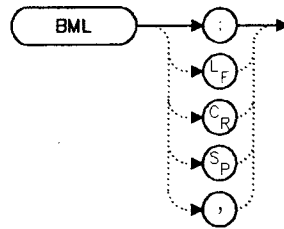

Description

The BML command subtracts the display line from trace B and places the result in dBm (when in log mode) in trace B, which is then set to view mode. In linear mode, the results are in volts.

Note



The displayed amplitude of each trace element falls into one of 600 data points. There are 10 additional points of overrange, which corresponds to one-sixth of a division. When adding or subtracting trace data, any results exceeding the limits are clipped at that limit.

Example

```
10  OUTPUT 718;"IP;"
20  OUTPUT 718;"BLANK TRA;"
30  OUTPUT 718;"CLRW TRB;TS;DL -50DBM;"
40  OUTPUT 718;"BML;"
50  END
```

CF

Center Frequency

Syntax

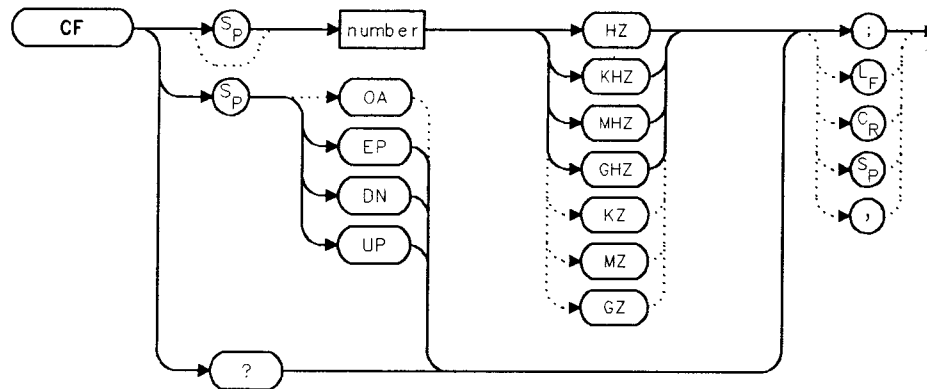

Description

The CF command sets the center frequency and sets the spectrum analyzer to center frequency/span mode. The span remains constant; the start and stop frequencies change as the center frequency changes.

Parameters

number real from 0 to 2.9E+9 (HP 8560A);
 0 to 6.5E+9 (HP 8561B);
 0 to 22.0E+9 (HP 8563A);
 0 to 26.5E+9 (HP 8563A Option 026);
 from 18E+9 to 325E+9 in external mixer mode.

UP/DN 10% of the frequency span or the amount set by the SS command.

Preset State

1.45 GHz (HP 8560A)
 3.25 GHz (HP 8561B)
 12.38 GHz (HP 8563A)
 14.63 GHz (HP 8563A Option 026)

CF Center Frequency

Query Response



Example

```
10  OUTPUT 718;"IP;"
20  OUTPUT 718;"CF 300MHZ;SP 20MHZ;TS;"
30  OUTPUT 718;"CF?;"
40  ENTER 718;Cf
50  PRINT Cf
60  END
```

CLRW Clear Write

Syntax

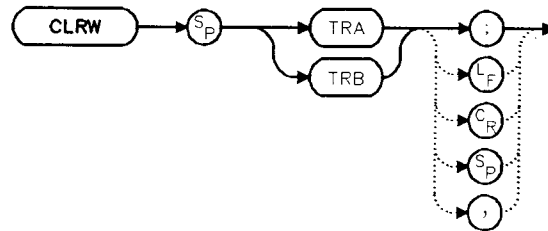

Description

The CLRW command sets the chosen trace to clear-write mode. This mode sets each element of the chosen trace to the bottom-screen value; then new data from the detector is put in the trace with each sweep.

Example

```

10  OUTPUT 718;"IP;"
20  OUTPUT 718;"BLANK TRA;CLRW TRB;"
30  END
  
```

CNVLOSS

Conversion Loss

Syntax

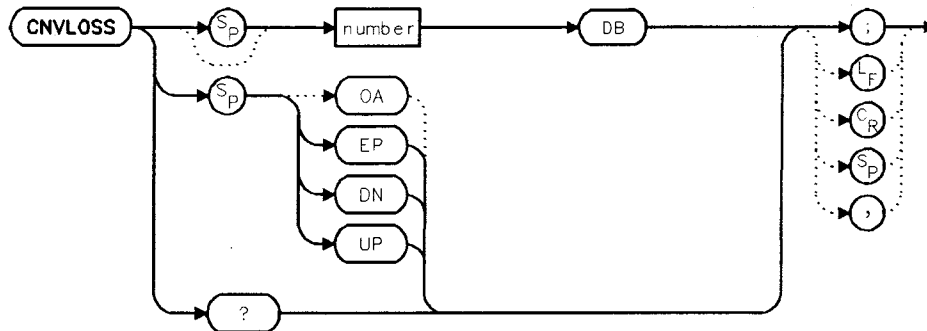

Description

The CNVLOSS command compensates for losses outside the instrument when in external mixer mode (such as losses within external mixers, connector cables, etc.). CNVLOSS specifies the mean conversion loss for the current harmonic band. In a full frequency band (such as band K), the mean conversion loss is defined as the minimum loss plus the maximum loss for that band divided by two. Adjusting for conversion loss allows the system to remain calibrated (that is, the displayed amplitude values have the conversion loss incorporated into them). The default value for any band is 30 dB. The spectrum analyzer must be in external-mixer mode in order for this command to work. When in internal-mixer mode, querying CNVLOSS returns a zero. This function is not available for an HP 8560A Option 002.

Parameters

number real from 15 to 60.
 UP/DN 0.1 dB.

Preset State

30 dB

Query Response



Example

```
10 OUTPUT 718;"IP;MXRMODE EXT;"
20 INPUT "ENTER DESIRED FREQUENCY BAND (KAQUVEWFDGY OR
J)",Fulband$
30 OUTPUT 718;"FULBAND ";Fulband$;" "
40 INPUT "ENTER IN THE CONVERSION LOSS FOR THAT BAND",Loss
50 OUTPUT 718;"CNVLOSS ";Loss;"DB;"
60 END
```

CONTS

Continuous Sweep

Syntax

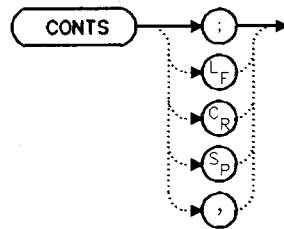

Description

The CONTS command activates the continuous-sweep mode. This mode enables another sweep at the completion of the current sweep once the trigger conditions are met.

Preset State

On

Example

```
10 OUTPUT 718;"CONTS;"  
20 END
```

COUPLE Input Coupling

Syntax

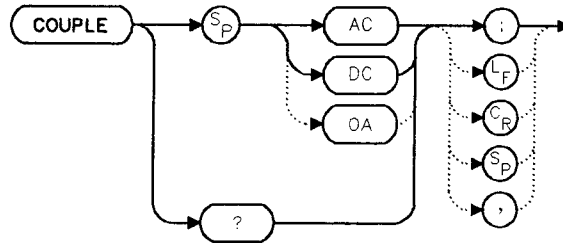

Description

The COUPLE command sets the input coupling to ac or dc coupling. AC coupling protects the input of the analyzer from damaging dc signals, while limiting the lower frequency-range to 100 kHz (although the analyzer will tune down to 0 Hz with signal attenuation). This command is not available in an HP 8563A; the HP 8563A is always dc coupled.

Preset State

AC

Query Response

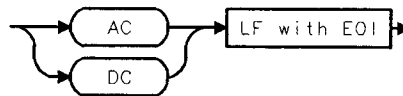

Example

```

10  OUTPUT 718;"COUPLE DC;"
20  PRINT "CAUTION:  ANALYZER IS NOW DC-COUPLED."
30  OUTPUT 718;"COUPLE?;"
40  ENTER 718;C$
50  PRINT C$
60  LOCAL 718
70  END

```

DEMODO

Demodulation

Syntax

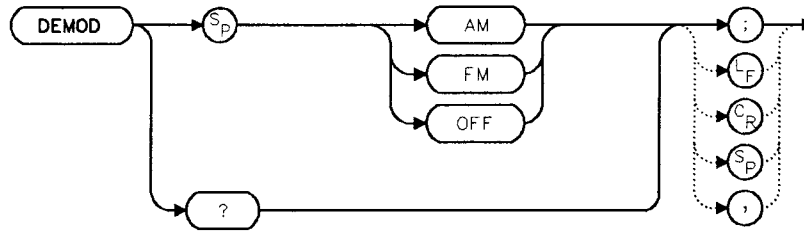

Description

The DEMOD command activates either AM or FM demodulation, or turns the demodulation off. Place a marker on a desired signal and then activate DEMOD; demodulation takes place on this signal. If no marker is on, DEMOD automatically places a marker at the center of the trace and demodulates the frequency at that marker position. Use the volume and squelch controls to adjust the speaker and listen. DEMOD does not function for resolution bandwidths less than 300 Hz.

Preset State

Off

Query Response

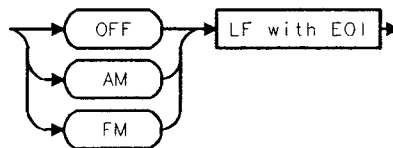

Example

```
10  OUTPUT 718;"IP;"
20  OUTPUT 718;"FA 88MHZ;FB 108MHZ;"
30  OUTPUT 718;"MKN EP;"
40  PRINT "MOVE MARKER TO SIGNAL TO BE DEMODULATED; PRESS HOLD."
50  PRINT "THEN PRESS CONTINUE"
60  PAUSE
70  INPUT "ENTER DEMODULATION TIME (.1 SEC - 60 SEC)",Dtime
80  OUTPUT 718;"DEMOMDT ";Dtime;"SEC;"
90  OUTPUT 718;"DEMOM FM;"
100 LOCAL 718
110 PRINT "ADJUST VOLUME AND SQUELCH AS NECESSARY."
120 END
```

DEMODAGC

Demodulation Automatic Gain Control

Syntax

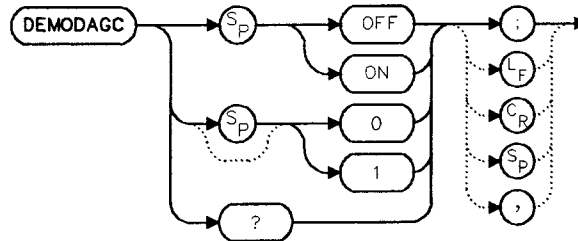

Description

The DEMODAGC command turns the demodulation automatic gain control (AGC) on or off. The AGC keeps the volume of the speaker relatively constant during AM demodulation. AGC is available only during AM demodulation and when the frequency span is greater than 0 Hz.

Preset State

Off

Query Response

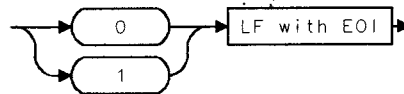

Example

```

10  OUTPUT 718;"IP;"
20  OUTPUT 718;"FA 550KHZ;FB 1600KHZ;"
30  OUTPUT 718;"MKN EP;"
40  PRINT "MOVE MARKER TO SIGNAL TO BE DEMODULATED; PRESS HOLD."
50  PRINT "THEN PRESS CONTINUE"
60  PAUSE
70  INPUT "ENTER DEMODULATION TIME (.1 - 60 SEC)",Dtime
80  OUTPUT 718;"DEMODT ";Dtime;"SEC;"
90  OUTPUT 718;"DEMOD AM;DEMODAGC ON;"
100 LOCAL 718
110 PRINT "ADJUST VOLUME AND SQUELCH AS NECESSARY."
120 END

```

DEMODT Demodulation Time

Syntax

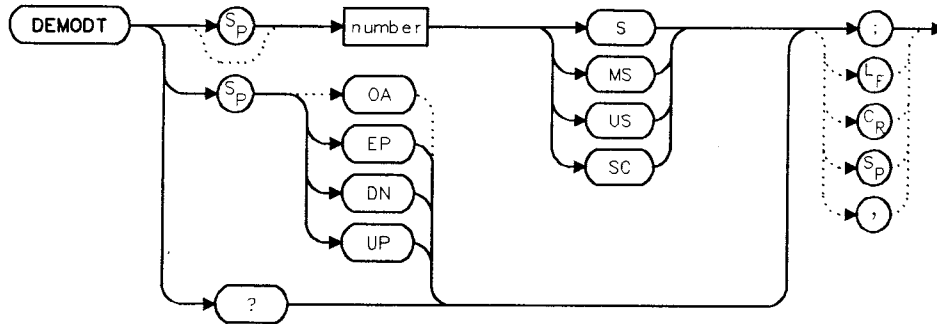

Description

The DEMODT command selects the amount of time that the sweep pauses at the marker to demodulate a signal. The default value is 1 second. When the frequency span equals 0 Hz, demodulation is continuous, except when between sweeps. For truly continuous demodulation, set the frequency span to 0 Hz and the trigger mode to single sweep (see TM).

Parameters

number real from 100E-3 to 60.
UP/DN increments in a 1, 2, 5, 10 sequence.

Preset State

Off

Query Response



DEMODT Demodulation Time

Example

```
10  OUTPUT 718;"IP;"
20  OUTPUT 718;"FA 88MHZ;FB 108MHZ;"
30  OUTPUT 718;"MKN EP;"
40  PRINT "MOVE MARKER TO SIGNAL TO BE DEMODULATED; PRESS HOLD."
50  PRINT "THEN PRESS CONTINUE"
60  PAUSE
70  INPUT "ENTER DEMODULATION TIME (.1 SEC - 60 SEC)",Dtime
80  OUTPUT 718;"DEMODT ";Dtime;"SEC;"
90  OUTPUT 718;"DEMOD FM;"
100 LOCAL 718
110 PRINT "ADJUST VOLUME AND SQUELCH AS NECESSARY."
120 END
```

DET Detection Modes

Syntax

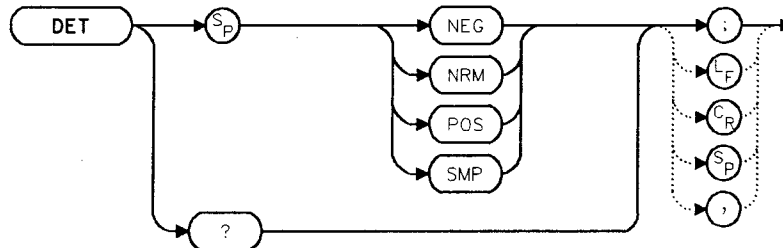

Description

The DET command specifies the IF detector used for acquiring measurement data. This is normally a coupled function, in which the spectrum analyzer selects the appropriate detector mode. Four modes are available: normal, positive, negative, and sample. The modes are described below. When a mode other than normal is chosen, a "D" appears on the left side of the display.

Parameters

- NEG selects the negative peak detector. The minimum signal values are displayed.
- NRM selects the normal peak detector, which displays both positive and negative peak values. The noise floor is made up of alternately selected positive and negative peaks. When a signal is encountered, the positive peak detector is used.
- POS selects the positive peak detector. The maximum signal values are displayed.
- SMP selects the sample mode, which places the instantaneous signal value of the analog-to-digital conversion in memory.

If no detector mode is specified, the following rules determine the chosen detector.

1. If video averaging or marker noise functions are on, or if the resolution bandwidth is greater than 300 Hz and the video bandwidth is less than 300 Hz, the detector is set to sample mode. If the resolution bandwidth is less than 300 Hz, sample mode can be selected independent of the video bandwidth.
2. If the maximum-hold trace mode is on, the positive peak detector is used.
3. If the minimum-hold trace mode is on, the negative peak detector is used.
4. If none of the above rules apply, the normal detector is used.
5. If more than one of the above rules apply, the first rule listed determines the detector used.

DET Detection Modes

Preset State

Coupled mode, normal detector

Query Response

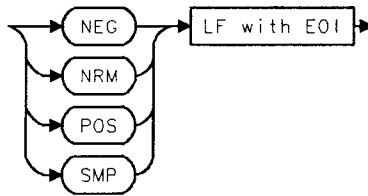

Example

```
10 INPUT "SELECT A DETECTOR MODE (NEG, NRM, POS, OR SMP)",Det$
20 OUTPUT 718;"DET ";Det$;" "
30 PRINT "CHOSEN DETECTOR MODE IS ",Det$
40 END
```

DL Display Line

Syntax

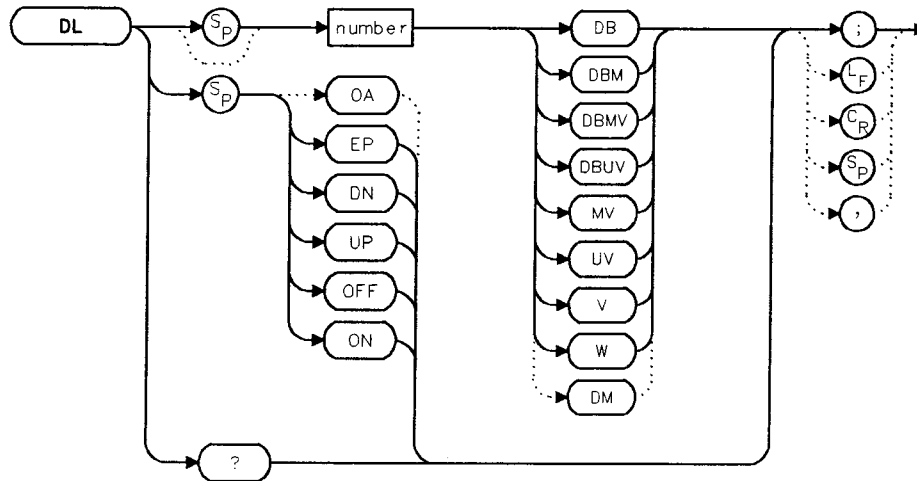

Description

The DL command activates a horizontal display line for use as a visual aid or for computational purposes. The default value is 0 dBm.

Parameters

number real. Dependent on the selected amplitude units.
UP/DN changes the display line by one vertical division.

Preset State

Off

Query Response

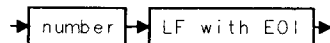

DL Display Line

Example

```
10  INPUT "ENTER START FREQUENCY, IN MHZ",Fa
20  INPUT "ENTER STOP FREQUENCY, IN MHZ",Fb
30  OUTPUT 718;"AUNITS DBUV;"
40  OUTPUT 718;"FA ";Fa;"MHZ;"
50  OUTPUT 718;"FB ";Fb;"MHZ;"
60  OUTPUT 718;"DL 48DBUV;"
70  END
```

DONE Done

Syntax

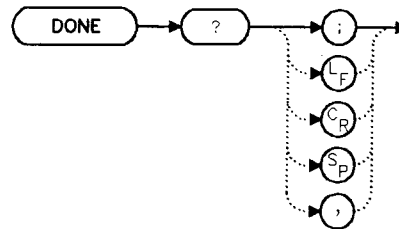

Description

The DONE command sends a "1" to the controller when all commands in a command string entered before DONE have been completed. Sending a TS command before DONE ensures that the spectrum analyzer will complete a full sweep before continuing on in a program.

Query Response

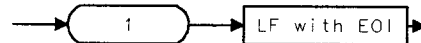

Example

```

10  OUTPUT 718;"IP;CF 1GHZ;SP 2GHZ;TS;DONE?;"
20  ENTER 718;Done
30  PRINT "COMMAND STRING IS DONE"
40  END

```

ERR

Error

Syntax

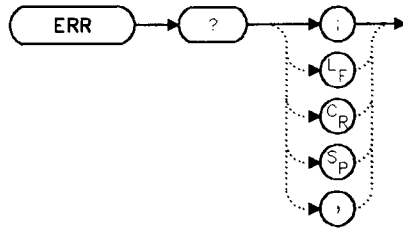

Description

The ERR command outputs a list of errors present. An error code of "0" means there are no errors present. For a list of error codes and descriptions, refer to Appendix C or the Installation and Verification Manual. Executing ERR clears all HP-IB errors. For best results, enter error data immediately after querying for errors. Each error code is three digits long.

Preset State

Remote error list cleared. (Persistent errors are reentered into the error list.)

Query Response

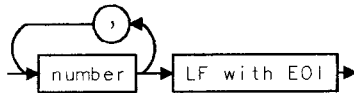

Example

```
10  DIM Err$[200]
20  OUTPUT 718;"ERR?;"
30  ENTER 718;Err$
40  PRINT Err$
50  !the following routine removes the comma between errors in
    a string
60  Position_comma=POS(Err$,",")
70  IF Position_comma>0 THEN
80    !multiple errors
90    First_error=VAL(Err$)
100   PRINT First_error
110   Err$=Err$[POS(Err$,",")+1]
120   REPEAT
130     Position_comma=POS(Err$,",")
140     Next_error=VAL(Err$)
150     PRINT Next_error
160     IF Position_comma THEN Err$=Err$[POS(Err$,",")+1]
170   UNTIL Position_comma=0
180 ELSE
190   Err=VAL(Err$)
200   IF Err<>0 THEN
210     PRINT Err
220   ELSE
230     PRINT "NO ERRORS"
240   END IF
250 END IF
260 !end routine
270 END
```

ET Elapsed Time

Syntax

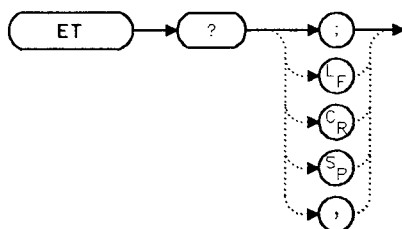

Description

The ET command returns to the controller the elapsed time (in hours) of analyzer operation. This value can be reset only by Hewlett-Packard.

Query Response

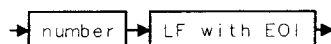

Example

```
10 OUTPUT 718;"ET?;"
20 ENTER 718;Et
30 PRINT Et
40 END
```

EXTMXR External Mixer Mode

Syntax

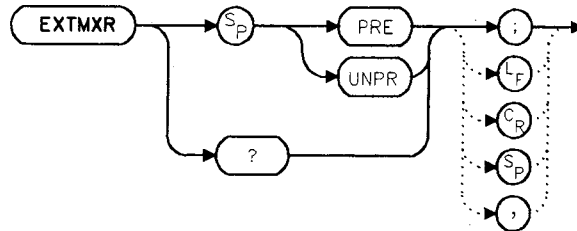

Description

The EXTMXR command specifies the external mixing mode as either preselected (PRE) or unpreselected (UNPR). This command applies only to the selection of the type of external mixer to be used. It does not switch the analyzer from internal to external mixing. This command is not available for use with an HP 8560A Option 002.

Query Response

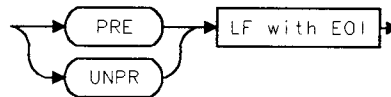

Example

```

10 OUTPUT 718;"EXTMXR PRE;"
20 END
  
```

FA Start Frequency

Syntax

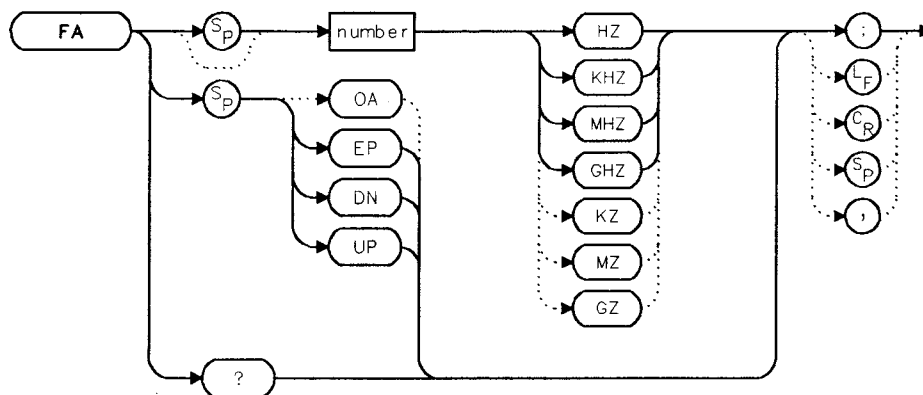

Description

The FA command sets the start frequency and sets the spectrum analyzer to start-frequency/stop-frequency mode. If the start frequency exceeds the stop frequency, the stop frequency increases to equal the start frequency plus the minimum span. The center frequency and span change with changes in the start frequency.

Parameters

number real from 0 to 2.9E+9 (HP 8560A);
 0 to 6.5E+9 (HP 8561B);
 0 to 22.0E+9 (HP 8563A);
 0 to 26.5E+9 (HP 8563A Option 026);
 from 18E+9 to 325E+9 in external mixer mode.
UP/DN increments in 10% of span.

Preset State

0 Hz (HP 8560A and HP 8561B)
2.75 GHz (HP 8563A)

Query Response

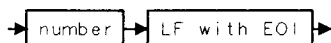

Example

```
10  OUTPUT 718;"FA 88MHZ;FB 108MHZ;"
20  OUTPUT 718;"FA?;"
30  ENTER 718;Fa
40  PRINT Fa
50  END
```

FB Stop Frequency

Syntax

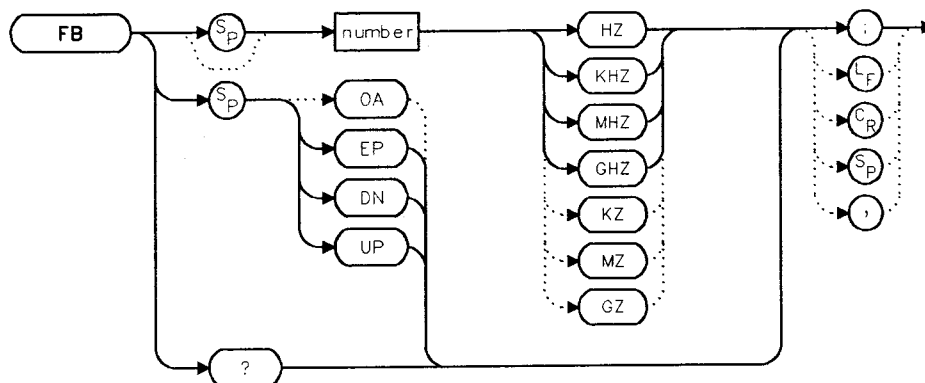

Description

The FB command sets the stop frequency and sets the spectrum analyzer to start-frequency/stop-frequency mode. If the stop frequency is less than the start frequency, the start frequency decreases to equal the stop frequency minus 100 Hz. The center frequency and span change with changes in the stop frequency.

Parameters

- number real from 0 to 2.9E+9 (HP 8560A);
 0 to 6.5E+9 (HP 8561B);
 0 to 22.0E+9 (HP 8563A);
 0 to 26.5E+9 (HP 8563A Option 026);
 from 18E+9 to 325E+9 in external mixer mode.
- UP/DN increments in 10% of span.

Preset State

- 2.9 GHz (HP 8560A)
- 6.5 GHz (HP 8561B)
- 22 GHz (HP 8563A)
- 26.5 GHz (HP 8563A Option 026)

Query Response



Example

```
10 OUTPUT 718;"FA 88MHZ;FB 108MHZ;"
20 OUTPUT 718;"FB?;"
30 ENTER 718;Fb
40 PRINT Fb
50 END
```

FDIAG

Frequency Diagnostics

Syntax

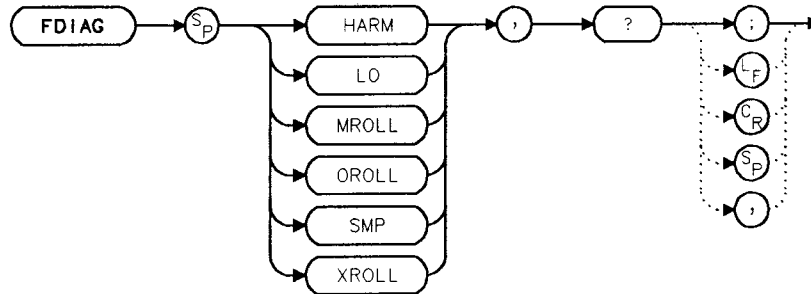

Description

The FDIAG command activates the frequency diagnostic routine, which returns the frequency of the specified oscillator.

Parameters

- LO returns the first local oscillator frequency corresponding to the current start frequency.
- SMP returns the sampling oscillator frequency corresponding to the current start frequency.
- HARM returns the sampler harmonic number corresponding to the current start frequency.
- MROLL returns the main roller oscillator frequency corresponding to the current start frequency, except when the resolution bandwidth is less than or equal to 100 Hz.
- OROLL returns the offset roller oscillator frequency corresponding to the current start frequency, except when the resolution bandwidth is less than or equal to 100 Hz.
- XROLL returns the transfer roller oscillator frequency corresponding to the current start frequency, except when the resolution bandwidth is less than or equal to 100 Hz.

Note

In multiband sweeps, the above frequencies correspond to the band being swept when the command is executed.



Query Response



Example

```
10  OUTPUT 718;"FDIAG SMP,?;"  
20  ENTER 718;Fdiag  
30  PRINT "DIAGNOSTIC FREQUENCY IS ",Fdiag  
40  END
```

FDSP

Frequency Display Off

Syntax

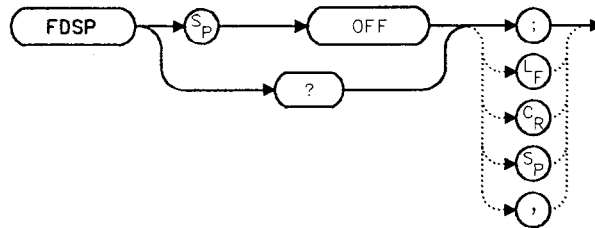

Description

The FDSP command turns off all annotation that describes the spectrum analyzer frequency setting. This includes the start and stop frequencies, the center frequency, the frequency span, marker readouts, the center frequency step-size, and signal identification to center frequency. To retrieve the frequency data, query the spectrum analyzer. To reactivate the annotation, execute the IP command.

Preset State

On

Query Response

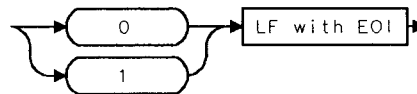

Example

```
10 OUTPUT 718;"FDSP OFF;";  
20 OUTPUT 718;"FDSP?";  
30 ENTER 718;Fdsp  
40 PRINT Fdsp  
50 END
```

FFT Fast Fourier Transform

Syntax

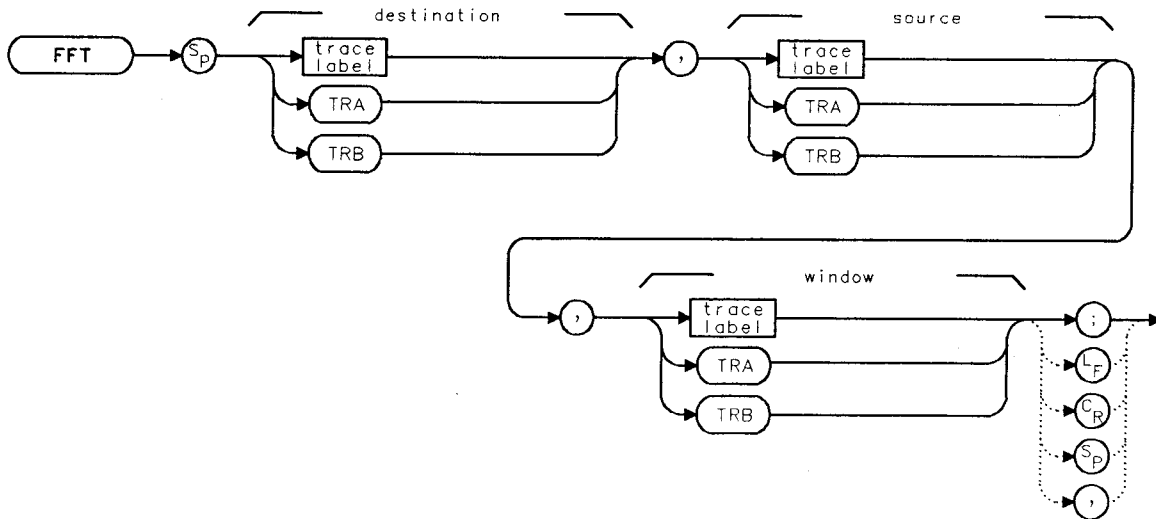

Description

The FFT command performs a discrete Fourier transform on the source trace array and stores the logarithms of the magnitudes of the results in the destination array. The maximum length of any of the traces is 601 points.

FFT is designed to be used in transforming zero-span amplitude-modulation information into the frequency domain. Performing an FFT on a frequency sweep will not provide time-domain results and is not recommended.

The FFT results are displayed on the spectrum analyzer in a logarithmic amplitude scale. For the horizontal dimension, the frequency at the left side of the graticule is 0 Hz, and at the right side is F_{max} . F_{max} is equal to 300 divided by sweep time.

As an example, if the sweep time of the analyzer is 60 ms, F_{max} equals 5 kHz.

The FFT algorithm assumes that the sampled signal is periodic with an integral number of periods within the time-record length (that is, the sweep time of the analyzer). Given this assumption, the transform computed is that of a time waveform of infinite duration, formed of concatenated time records. In actual measurements, the number of periods of the sampled signal within the time record may not be integral. In this case, there is a step discontinuity at the intersections of the concatenated time records in the assumed time waveform of infinite duration. This step discontinuity causes measurement errors, both amplitude uncertainty (where the signal level appears to vary with small changes in frequency) and frequency resolution (due to filter shape factor and sidelobes). Windows are weighting functions that are applied to the input data to force the ends of that data smoothly to zero, thus reducing the step discontinuity and reducing measurement errors.

FFT Fast Fourier Transform

There are three types of windows which are available, using the TWNDOW command.

- FLATTOP provides optimum amplitude accuracy.
- HANNING provides an amplitude accuracy/frequency resolution compromise, which is useful for general purpose measurements, as well as noise measurements.
- UNIFORM provides equal weighting of the time record for measuring transients.

Some important parameters of the three available windows are shown in the table below. In the bandwidth entries, multiply the entry by one-divided-by-sweeptime (1/sweeptime).

Bandwidth Factors

	FLATTOP	HANNING	UNIFORM
Noise Equivalent Bandwidth	3.63×	1.5×	1×
3 dB Bandwidth	3.60×	1.48×	1×
Sidelobe height	<-90 dB	-32 dB	-13 dB
Amplitude uncertainty	0.10 dB	1.42 dB	3.92 dB
Shape factor (60 dB BW/3 dB BW)	2.6	9.1	>300

Example

```
10 OUTPUT 718;"IP;"
20 OUTPUT 718;"CF 300 MHZ;"
30 OUTPUT 718;"SP OHZ;ST 50MS;"
40 OUTPUT 718;"TWNDOW TRA, UNIFORM;"
50 OUTPUT 718;"CLRW TRB;"
60 OUTPUT 718;"SNGLS;TS;TS;"
70 OUTPUT 718;"FFT TRA,TRB,TRA;"
80 OUTPUT 718;"BLANK TRB;"
90 OUTPUT 718;"VIEW TRA;"
100 END
```

FOFFSET

Frequency Offset

Syntax

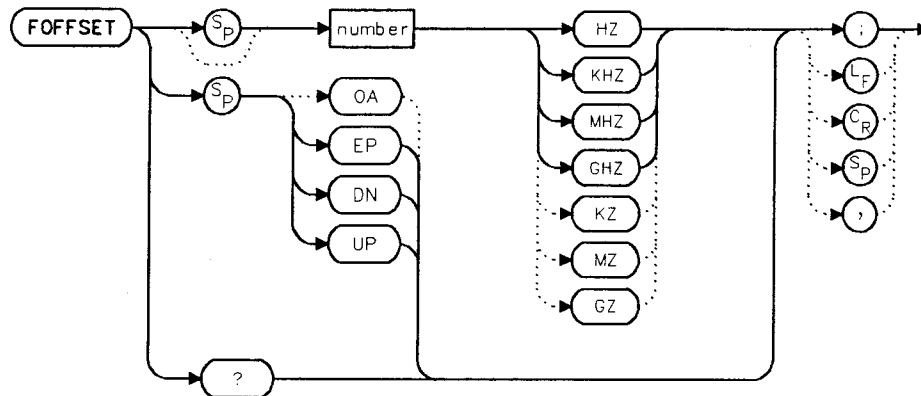

Description

The FOFFSET command adds a specified offset to the displayed absolute-frequency values, including marker-frequency values. It does not affect the frequency range of the sweep, nor does it affect relative frequency readouts. When this function is active, an "F" appears on the left side of the display.

Parameters

number real from 0 to 2.9E+9 (HP 8560A);
 real from 0 to 6.5E+9 (HP 8561B);
 real from 0 to 22E+9 (HP 8563A).
 UP/DN changes by 10% of span.

Preset State

Off

Query Response



FOFFSET Frequency Offset

Example

```
10 INPUT "ENTER DESIRED FREQUENCY OFFSET IN HERTZ",Foffset
20 OUTPUT 718;"FOFFSET ";Foffset;"HZ;"
30 OUTPUT 718;"FOFFSET?;"
40 ENTER 718;Foffset
50 PRINT "THE FREQUENCY OFFSET IS",Foffset,"HZ"
60 END
```

FREF Frequency Reference

Syntax

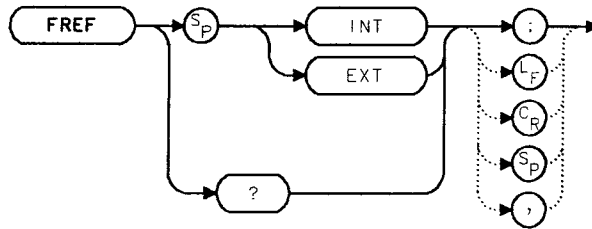

Description

The FREF command specifies the frequency reference source. Select either the internal frequency reference (INT) or supply your own external reference (EXT). An external reference must be 10 MHz (± 100 Hz) at a minimum amplitude of 0 dBm. Connect the external reference to J9 (10 MHz REF IN/OUT) on the rear panel. When the external mode is selected, an "X" appears on the left edge of the display.

Preset State

Internal

Query Response

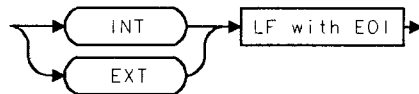

Example

```

10 INPUT "WHAT IS THE FREQUENCY REFERENCE SOURCE (INT OR
20 OUTPUT 718;"FREF ";Src$";"
30 PRINT "SOURCE SELECTED IS",Src$
40 END
  
```

FS Full Span

Syntax

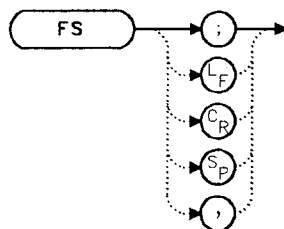

Description

The FS command selects the full frequency span as defined by the instrument. The full span is 2.9 GHz for the HP 8560A. For the HP 8561B, full span is 6.5 GHz. For the HP 8563A, full span is 2.9 GHz in low band, 19.25 GHz in high band, or 23.75 GHz if an Option 026.

Example

```
10 OUTPUT 718;"FS;"  
20 END
```

FULBAND Full Band

Syntax

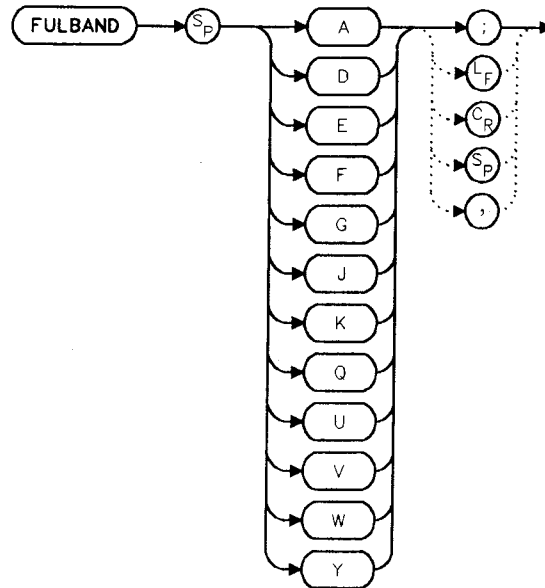

Note When in preselected external mixing mode, band K is not available.



Description

The FULBAND command selects a commonly-used, external-mixer frequency band, as shown in Table 5-3. The harmonic lock function (HNLOCK) is also set; this locks the harmonic of the chosen band. External-mixing functions are not available with an HP 8560A Option 002.

FULBAND Full Band

Table 5-3. External-Mixer Frequency Bands

Frequency Band	Frequency Range (GHz)	Mixing Harmonic	Conversion Loss
K	18.0 to 26.5	6-	30 dB
A	26.5 to 40.0	8-	30 dB
Q	33.0 to 50.0	10-	30 dB
U	40.0 to 60.0	10-	30 dB
V	50.0 to 75.0	14-	30 dB
E	60.0 to 90.0	16-	30 dB
W	75.0 to 110.0	18-	30 dB
F	90.0 to 140.0	24-	30 dB
D	110.0 to 170.0	30-	30 dB
G	140.0 to 220.0	36-	30 dB
Y	170.0 to 260.0	44-	30 dB
J	220.0 to 325.0	54-	30 dB

Example

```
10  OUTPUT 718;"IP;MXRMODE EXT;"
20  INPUT "ENTER DESIRED FREQUENCY BAND (KAQUVEWFDGY OR
J)",Fulband$
30  OUTPUT 718;"FULBAND ";Fulband$;"
40  OUTPUT 718;"MKN EP;"
50  PRINT "POSITION THE MARKER ON THE DESIRED SIGNAL."
60  PRINT "PRESS THE ANALYZER HOLD KEY, THEN PRESS CONTINUE."
70  PAUSE
80  OUTPUT 718;"SNGLS;TS;SIGID AUTO;DONE?;"
90  ENTER 718;Done
100 OUTPUT 718;"IDFREQ?;"
110 ENTER 718;Idfreq
120  IF Idfreq<>0 THEN
130  PRINT Idfreq
140  ELSE
150  PRINT "NO SIGNAL FOUND"
160  END IF
170 OUTPUT 718;"CONTS;"
180 LOCAL 718
190 END
```

GRAT Graticule On/Off

Syntax

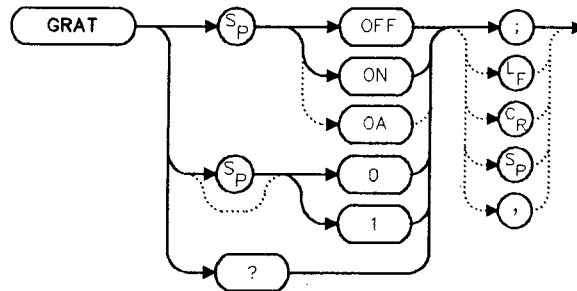

Description

The GRAT command turns the display graticule on or off.

Preset State

On

Query Response

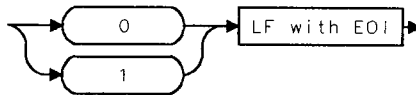

Example

```

10  OUTPUT 718;"GRAT OFF;"
20  OUTPUT 718;"GRAT?;"
30  ENTER 718;Grat
40  PRINT Grat
50  END

```

HD Hold

Syntax

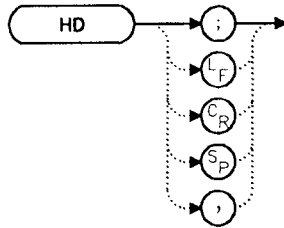

Description

The HD command freezes the active function at its current value. If no function is active, no operation takes place.

Example

```
10  OUTPUT 718;"IP;CF 300MHZ;SP 20MHZ;HD;"  
20  END
```

HNLOCK Harmonic Number Lock

Syntax

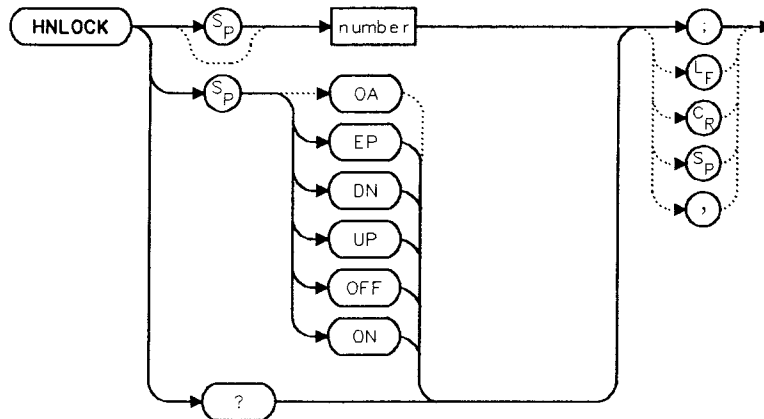

Description

The HNLOCK command locks a chosen harmonic so only that harmonic is used to sweep an external frequency band. To select a frequency band, use the FULBAND command; it selects an appropriate harmonic for the desired band. To change the harmonic number, use HNLOCK. Table 5-4 shows the frequency bands and the harmonics that sweep each band. Note that HNLOCK also works in internal-mixing modes.

Once FULBAND or HNLOCK are set, only center frequencies and spans that fall within the frequency band of the current harmonic may be entered. When the FS command is activated, the span is limited to the frequency band of the selected harmonic. This command is not available with an HP 8560A Option 002.

HNLOCK Harmonic Number Lock

Table 5-4. Frequency Bands and the Corresponding LO Harmonic

Frequency Range (GHz)	Mixing Harmonic
18.00 to 26.50	6-
26.50 to 40.00	8-
33.00 to 50.00	10-
40.00 to 60.00	10-
50.00 to 75.00	14-
60.00 to 90.00	16-
75.00 to 110.00	18-
40.00 to 140.00	24-
110.00 to 170.00	30-
140.00 to 220.00	36-
170.00 to 260.00	44-
220.00 to 325.00	54-

Parameters

number integer from 1 to 54 (for best results, choose from harmonic numbers shown in Table 5-4 above).
UP/DN increments of 1.

Preset State

Off

Query Response

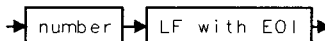

Example

```
10 OUTPUT 718;"IP;MXRMODE EXT;"
20 INPUT "SELECT THE START FREQUENCY, IN GHZ",Fa
30 INPUT "SELECT THE STOP FREQUENCY, IN GHZ",Fb
40 INPUT "ENTER HARMONIC DESIRED TO SWEEP RANGE",Harm
50 OUTPUT 718;"FA ";Fa;"GHZ;"
60 OUTPUT 718;"FB ";Fb;"GHZ;"
70 OUTPUT 718;"HNLOCK ";Harm;";"
80 END
```

HNUNLK Unlock Harmonic Number

Syntax

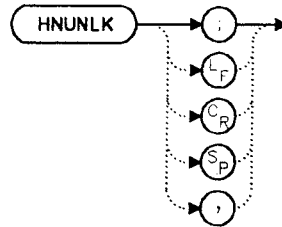

Description

The HNUNLK command unlocks the harmonic number, allowing you to select frequencies and spans outside the range of the locked harmonic number. Also, when HNUNLK is executed, more than one harmonic can then be used to sweep across a desired span. For example, sweep a span from 18 GHz to 40 GHz. In this case, the analyzer will automatically sweep first using 6–, then using 8–. This command is not available with an HP 8560A Option 002.

Example

```
10 OUTPUT 718;"IP;MXRMODE EXT;FULBAND Q;"
20 OUTPUT 718;"FA 18GHZ;FB 40GHZ;"
30 OUTPUT 718;"HNUNLK;"
40 END
```

ID

Output Identification

Syntax

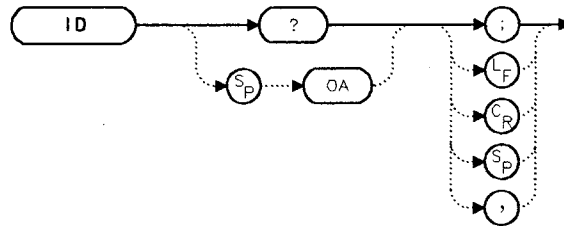

Description

The ID command returns the model number of the spectrum analyzer (HP 8560A, HP 8561B, or HP 8563A) and any options installed.

Query Response

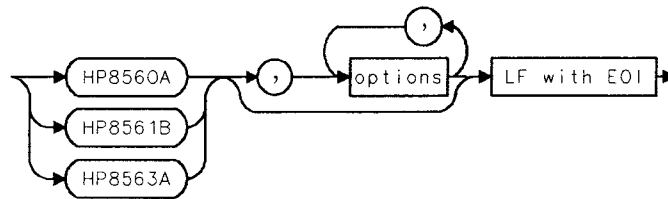

Example

```
10 DIM Id$[80]
20 OUTPUT 718;"ID?;"
30 ENTER 718;Id$
40 PRINT Id$
50 END
```

IDCF Signal Identification to Center Frequency

Syntax

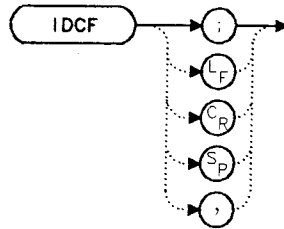

Description

The IDCF command sets the center frequency to the frequency obtained from the command SIGID. SIGID must be in AUTO mode and have found a valid result for this command to execute properly. Use SIGID on signals when in external mixing mode. IDCF does not apply to an HP 8560A Option 002 or when configured to use preselected external mixers.

Example

```

10  OUTPUT 718;"SIGID AUTO;"
20  OUTPUT 718;"IDCF;"
30  OUTPUT 718;"CF?;"
40  ENTER 718;Cf
50  PRINT Cf
60  END

```

IDFREQ

Signal Identified Frequency

Syntax

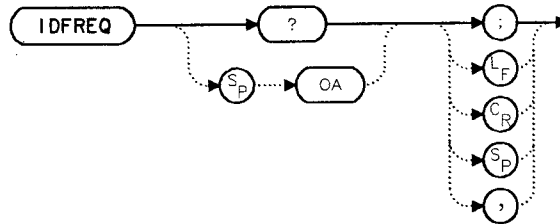

Description

The IDFREQ command returns the frequency of the last identified signal. After an instrument preset or an invalid signal identification, IDFREQ returns a "0." This command does not apply to an HP 8560A Option 002 or when configured to use preselected external mixers.

Query Response



Example

```
10 OUTPUT 718;"IDFREQ?;"
20 ENTER 718;Idfreq
30 PRINT Idfreq
40 END
```

IP Instrument Preset

Syntax

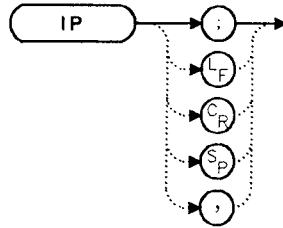

Description

The IP command sets the spectrum analyzer to a known, predefined state, shown in Table 5-5. IP does not affect the contents of any data or trace registers or stored preselector data. IP does not clear the input or output data buffers; to clear these, execute the statement CLEAR 718. Include the TS command after IP when the next command will operate on trace data (such as TRA).

Table 5-5. HP 8560A/8561B/8563A Preset State

Function	State
10 MHz REF	INTERNAL
A-B->A	OFF
A-B+DISPLAY LINE->A	OFF
AGC	OFF
ANNOTATION	ON
AUTO IF ADJUST	ON
BAND LOCK	OFF
CENTER FREQUENCY	1.45 GHz (HP 8560A); 3.25 GHz (HP 8561B); 12.375 GHz (HP 8563A)
CF STEP	290 MHz (HP 8560A); 650 MHz (HP 8561B); 1.925 GHz (HP 8563A); 2.375 GHz (HP 8563A Option 026)
DEMODULATION	FM OFF; AM OFF
DEMODULATION TIME	1 second
DETECTOR	NORMAL
DISPLAY LINE	0 dBm, OFF
EXT MIXER BIAS	0 mA
EXT MIXER LO HARMONIC	6
FREQUENCY COUNTER	OFF

Table 5-5. HP 8560A/8561B/8563A Preset State (continued)

Function	State
FREQUENCY COUNTER RESOLUTION	10 kHz
FREQUENCY DISPLAY	ON
FREQUENCY MODE	CENTER-SPAN
FREQUENCY OFFSET	0 Hz
GRATICULE	ON
INPUT ATTENUATION	10 dB, AUTO
MARKER MODE	OFF
MAX MIXER LEVEL	-10 dBm
MIXER	INT
MIXER CONV LOSS	30.0 dBm
NOISE MARKER	OFF
PEAK EXCURSION	6 dB
PEAK THRESHOLD	-130 dBm
PRESELECTOR PEAK TABLE	FACTORY DATA (HP 8561B, HP 8563A)
RBW/SPAN RATIO	0.011
REFERENCE LEVEL	0 dBm
REFERENCE LEVEL OFFSET	0 dB, OFF
RESOLUTION BW	1 MHz, AUTO
SIGNAL IDENTIFICATION	OFF
SIGNAL TRACK	OFF
SPAN	2.9 GHz (HP 8560A); 6.5 GHz (HP 8561B); 19.25 GHz (HP 8563A); 23.75 GHz (HP 8563A Option 026)
SQUELCH	OFF
SQUELCH LEVEL	-120 dBm
SWEEP TIME	60 ms, AUTO (HP 8560A); 200 ms, AUTO (HP 8561B); 400 ms, AUTO (HP 8563A) 500 ms, AUTO (HP 8563A Option 026)
THRESHOLD	-90 dBm, OFF
TRACE A	CLEAR-WRITE
TRACE B	BLANK
TRACE-DATA	FORMAT P
TRIGGER MODE	CONTINUOUS
TRIGGER SOURCE	FREE-RUN
UNITS	dBm, AUTO
VERTICAL SCALE	10 dB/DIV
VBW/RBW RATIO	1
VIDEO BW	1 MHz, AUTO
VIDEO AVERAGE	100, OFF
VIDEO TRIG LEVEL	0 dBm

Example

```
10 OUTPUT 718;"IP;SNGLS;"  
20 END
```

LG Logarithmic Scale

Syntax

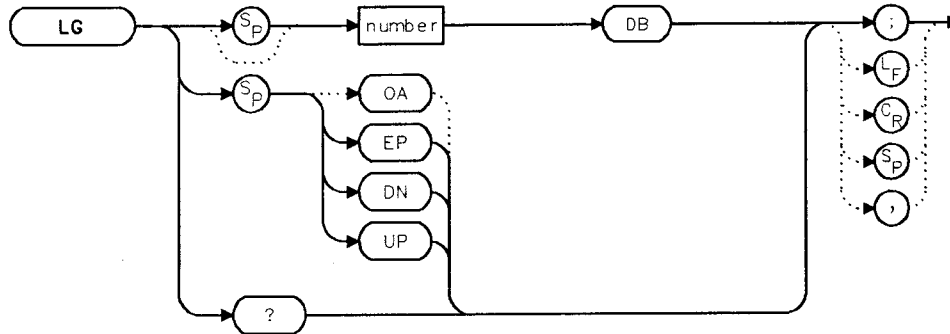

Description

The LG command selects a 1, 2, 5, or 10 dB logarithmic amplitude scale. When in linear mode, querying LG returns a "0". 1 dB/division and 5 dB/division scales are not available for sweep times less than 30 ms.

Parameters

number 1, 2, 5, or 10.
UP/DN increments in a 1, 2, 5, 10 sequence.

Preset State

10 dB/div

Query Response



Example

```

10  OUTPUT 718;"LG 10DB;"
20  OUTPUT 718;"AUNITS DBMV;"
30  OUTPUT 718;"TS;MKPK HI;MKRL;"
40  OUTPUT 718;"LG 2DB;"
50  END

```

LN Linear Scale

Syntax

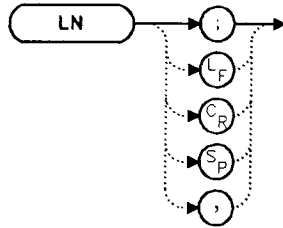

Description

The LN command selects a linear amplitude scale. Measurements made on a linear scale can be read out in any units.

Example

```
10  OUTPUT 718;"LN;"  
20  END
```

MBIAS

Mixer Bias

Syntax

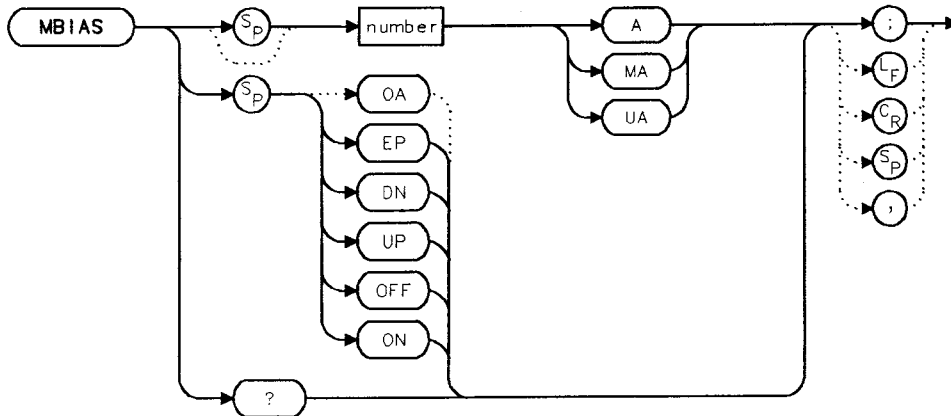

Description

The MBIAS command sets the bias for an external mixer that requires diode bias for efficient mixer operation. The bias, which is provided on the center conductor of the IF input, is activated when MBIAS is executed. A + or - appears on the left edge of the spectrum analyzer display, indicating that positive or negative bias is on. When the bias is turned off, MBIAS is set to 0. Default units are in milliamps. This function does not apply to an HP 8560A Option 002.

Caution



The open-circuit voltage can be as great as ± 3.5 V through a source resistance of 300 ohms. Such voltage may appear when recalling an instrument state in which an active bias has been stored.

Note



The bias value that appears on the spectrum analyzer display is expressed in terms of short-circuit current (the amount of current that would flow if the IF line were shorted to ground). The actual amount of current flowing into the mixer will be less.

Parameters

number real from 0.01 mA to -0.01 mA.
UP/DN increments of 0.1 mA.

Preset State

Off

Query Response

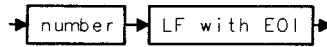

Example

```

10  OUTPUT 718;"IP;MXRMODE EXT;FULBAND U;"
20  OUTPUT 718;"MKN EP;"
30  PRINT "MOVE THE MARKER TO THE DESIRED SIGNAL"
40  PRINT "PRESS HOLD THEN PRESS CONTINUE"
50  PAUSE
60  INPUT "ENTER THE BIAS VALUE, IN MA",Bias
70  OUTPUT 718;"MBIAS ";Bias;"MA;"
80  OUTPUT 718;"MBIAS EP;"
90  PRINT "ADJUST BIAS IF NECESSARY"
100 PRINT "PRESS HOLD THEN PRESS CONTINUE"
110 PAUSE
120 OUTPUT 718;"SIGID AUTO;TS;DONE?;"
130 ENTER 718;Done
140 PRINT Done
150 END
  
```

MINH

Minimum Hold

Syntax

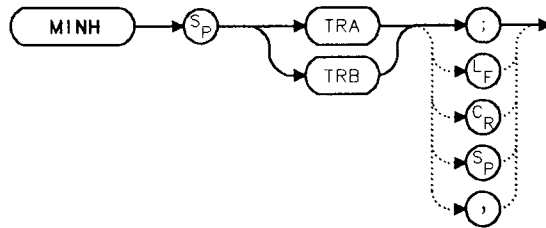

Description

The MINH command updates the chosen trace with the minimum signal level detected at each trace-data point from subsequent sweeps. This function employs the negative peak detector (refer to the DET command).

Example

```
10  OUTPUT 718;"IP;SNGLS;"
20  INPUT "ENTER START FREQUENCY, IN MHZ",Fa
30  INPUT "ENTER STOP FREQUENCY, IN MHZ",Fb
40  OUTPUT 718;"FA ";Fa;"MHZ;"
50  OUTPUT 718;"FB ";Fb;"MHZ;"
60  OUTPUT 718;"TS;MINH TRA;"
70  OUTPUT 718;"TS;MKPK HI;MKD;"
80  OUTPUT 718;"TS;MKPK NH;MKA?;AUNITS?;"
90  ENTER 718 USING "K";Difference,Aunits$
100 PRINT "DIFFERENCE IN AMPLITUDE IS ",Difference,Aunits$
110 LOCAL 718
120 END
```

MKA Marker Amplitude

Syntax

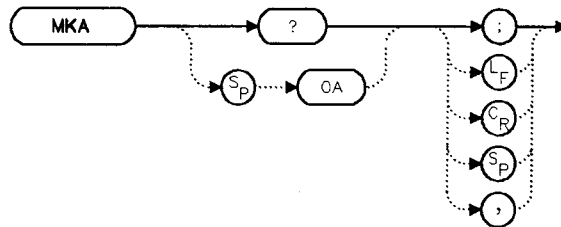

Description

The MKA command returns the amplitude of the active marker. If no marker is active, MKA places a marker at the center of the trace and returns that amplitude value.

Query Response

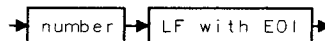

Example

```

10  OUTPUT 718;"IP;SNGLS;"
20  INPUT "ENTER IN DESIRED CENTER FREQUENCY, IN MHZ",Cf
30  INPUT "ENTER IN DESIRED FREQUENCY SPAN, IN MHZ",Sp
40  OUTPUT 718;"CF ";Cf;"MHZ;"
50  OUTPUT 718;"SP ";Sp;"MHZ;"
60  OUTPUT 718;"TS;MKPK HI;"
70  OUTPUT 718;"MKA?;AUNITS?;"
80  ENTER 718 USING "K";Mka,Aunits$
90  PRINT "HIGHEST PEAK IS",Mka,Aunits$
100 END

```

MKBW Marker Bandwidth

Syntax



Description

When used remotely, the MKBW command finds the signal's bandwidth at the power level in dB below the on-screen marker (if a marker is present) or the signal peak (if no on-screen marker is present). When the command is used manually, a peak search is automatically performed, and the bandwidth of the largest signal on-screen is displayed in the message area.

Parameter

integer any valid negative integer (0 to the amplitude of the noise floor).

Example

```
10  OUTPUT 718;"IP;"
20  OUTPUT 718;"CF 300MHZ;SP 100MHZ;SNGLS;"
30  OUTPUT 718;"TS;MKPK HI;"
40  OUTPUT 718;"MKBW -3,?;"
50  ENTER 718;MKBW,?;"
60  END
```

MKCF Marker to Center Frequency

Syntax

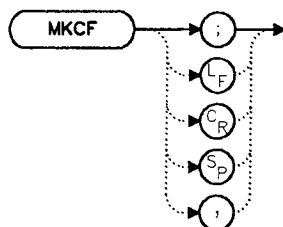

Description

The MKCF command sets the center frequency to the frequency value of an active marker.

Example

```
10  OUTPUT 718;"IP;SNGLS;"
20  INPUT "ENTER IN DESIRED START FREQUENCY, IN MHZ",Fa
30  INPUT "ENTER IN DESIRED STOP FREQUENCY, IN MHZ",Fb
40  OUTPUT 718;"FA ";Fa;"MHZ;"
50  OUTPUT 718;"FB ";Fb;"MHZ;"
60  OUTPUT 718;"TS;MKPK HI;MKCF;TS;"
70  END
```

MKD Marker Delta

Syntax

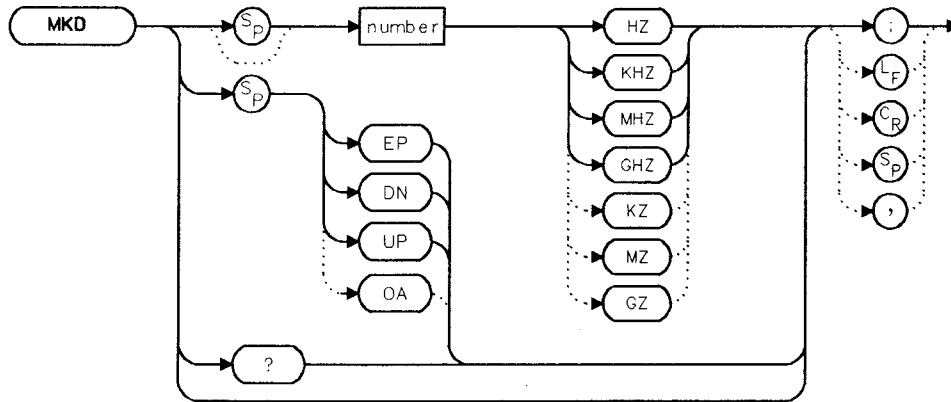

Description

The MKD command places a second marker on the trace. The number specifies the distance in frequency or time (when in zero span) between the two markers. When using zero span, data entered or output is always interpreted as microseconds (US).

Parameters

number dependent upon the chosen span.
UP/DN increments in 10% of span.

Query Response



Example

```

10  OUTPUT 718;"IP;CF 450MHZ;SP 400MHZ;"
20  OUTPUT 718;"TS;MKPK HI;MKD 300MHZ;"
30  OUTPUT 718;"MKPK HI;MKD;MKPK NH;MKD?;"
40  ENTER 718;Mkd
50  PRINT Mkd
60  END

```

MKDR

Reciprocal of Marker Delta

Syntax

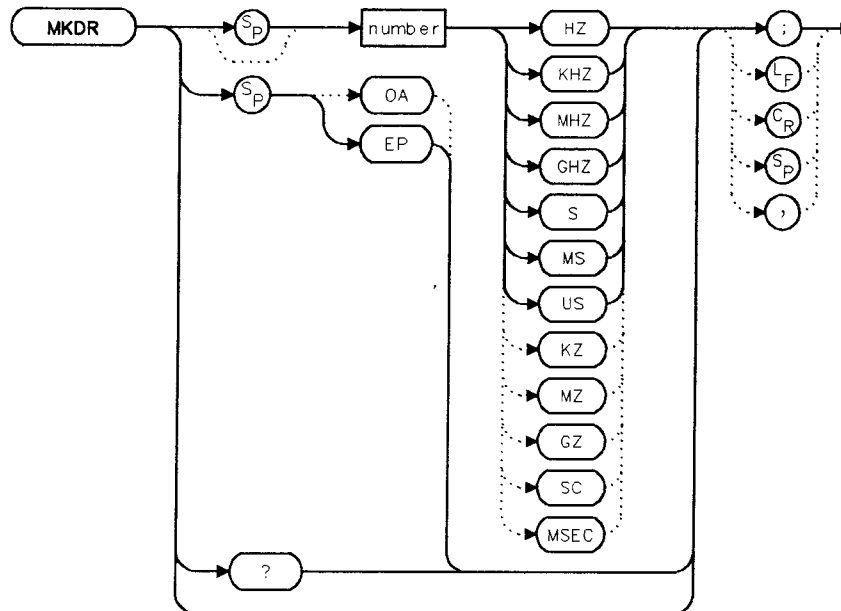

Description

The MKDR command displays the reciprocal of the frequency or time (when in zero span) difference between two markers.

Parameter

number from 10E-12 to 20E+3.

Query Response



Example

```

10  OUTPUT 718;"CF 300MHZ;SP 200MHZ;"
20  OUTPUT 718;"TS;MKPK HI;MKD;MKPK NH;MKDR?;"
30  ENTER 718;Period
40  PRINT "THE TIME PERIOD IS ",Period
50  END
  
```

MKF

Marker Frequency

Syntax

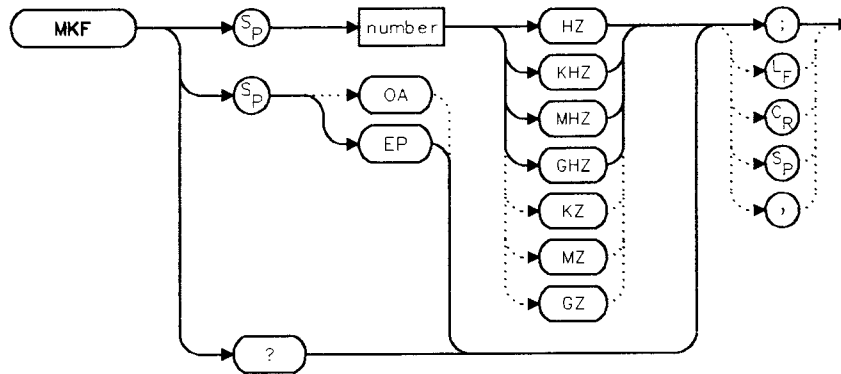

Description

The MKF command places an active marker on the chosen frequency or can be queried to return the frequency of the active marker. Default units are in Hertz.

Parameter

number real from 0 to 2.9E+9 (HP 8560A);
 0 to 6.5E+9 (HP 8561B);
 0 to 22E+9 (HP 8563A);
 0 to 26.5E+9 (HP 8563A Option 026);
 from 18E+9 to 325E+9 in external mixer mode.

Query Response



Example

```

10  OUTPUT 718;"CF 300MHZ;SP 20MHZ;MKF 290MHZ;"
20  OUTPUT 718;"TS;MKPK HI;MKF?;"
30  ENTER 718;Marker_freq
40  PRINT Marker_freq
50  END

```

MKFC Frequency Counter

Syntax

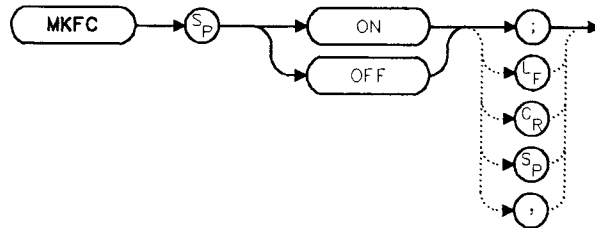

Description

The MKFC command activates a frequency counter that counts the frequency of the active marker or the difference in frequency between two markers. If no marker is active, MKFC places a marker at the center of the trace and counts that marker frequency. The frequency counter provides a more accurate frequency reading; it completes a sweep, zooms in on the marked signal, goes into zero span, counts the value, and then starts a new sweep. To adjust the frequency counter resolution, use the MKFCR command. To return the counter value, use the MKF command.

Preset State

Off

Example

```

10  INPUT "ENTER IN THE DESIRED CENTER FREQUENCY, IN MHZ",Freq
20  INPUT "ENTER IN THE DESIRED FREQUENCY SPAN, IN MHZ",Span
30  OUTPUT 718;"IP;CF ";Freq;"MHZ;"
40  OUTPUT 718;"SP ";Span;"MHZ;"
50  INPUT "ENTER DESIRED FREQUENCY-COUNTER RESOLUTION, IN
HZ",Resolution
60  OUTPUT 718;"MKFCR ";Resolution;"HZ;",
70  OUTPUT 718;"MKN EP;"
80  PRINT "PLACE THE MARKER ON THE DESIRED SIGNAL."
90  PRINT "PRESS HOLD ON THE ANALYZER, THEN PRESS CONTINUE."
100 PAUSE
110 OUTPUT 718;"MKFC ON;"
120 END

```

MKFCR

Frequency Counter Resolution

Syntax

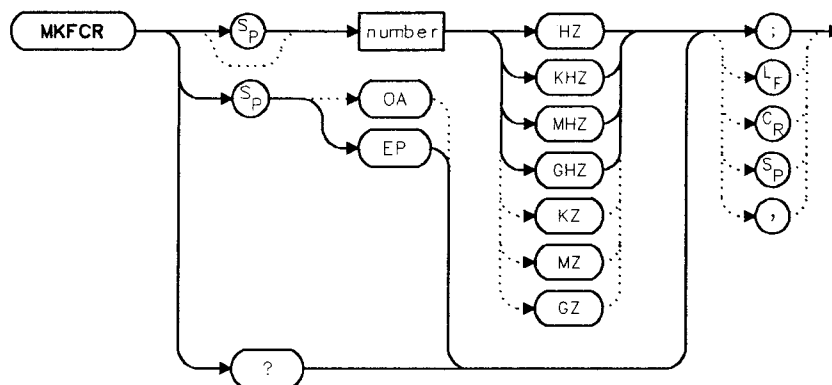

Description

The MKFCR command specifies the resolution of the frequency counter. Refer to the MKFC command. The default value is 10 kHz.

Parameter

number 1 Hz to 1 MHz, in powers of ten.

Query Response

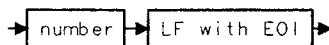

Example

```
10  INPUT "ENTER IN THE DESIRED CENTER FREQUENCY, IN MHZ",Freq
20  INPUT "ENTER IN THE DESIRED FREQUENCY SPAN, IN MHZ",Span
30  OUTPUT 718;"IP;CF ";Freq;"MHZ;"
40  OUTPUT 718;"SP ";Span;"MHZ;"
50  INPUT "ENTER DESIRED FREQUENCY-COUNTER RESOLUTION, IN
    HZ",Resolution
60  OUTPUT 718;"MKFCR ";Resolution;"HZ;",
70  OUTPUT 718;"MKN EP;"
80  PRINT "PLACE THE MARKER ON THE DESIRED SIGNAL."
90  PRINT "PRESS HOLD ON THE ANALYZER, THEN PRESS CONTINUE."
100 PAUSE
110 OUTPUT 718;"MKFC ON;"
120 OUTPUT 718;"MKF?;"
130 ENTER 718;Freq_count
140 PRINT "FREQUENCY IS",Freq_count,"HZ"
150 END
```

MKMIN

Marker to Minimum

Syntax

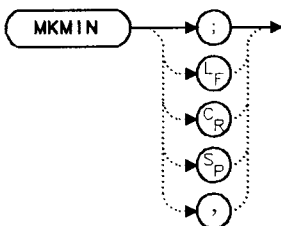

Description

The MKMIN command places an active marker on the minimum signal detected on a trace.

Example

```
10  OUTPUT 718;"IP;SNGLS;"
20  INPUT "ENTER IN THE START FREQUENCY, IN MHZ",Start_freq
30  INPUT "ENTER IN THE STOP FREQUENCY, IN MHZ",Stop_freq
40  OUTPUT 718;"FA ";Start_freq;"MHZ"
50  OUTPUT 718;"FB ";Stop_freq;"MHZ"
60  OUTPUT 718;"TS;MKPK HI;MKD;MKMIN;MKF?;"
70  ENTER 718;Delta_freq
80  OUTPUT 718;"MKA?;"
90  ENTER 718;Delta_amp
100 PRINT "DIFFERENCE IN FREQUENCY IS ",Delta_freq,"HZ"
110 PRINT "DIFFERENCE IN AMPLITUDE IS",Delta_amp,"DB"
120 END
```

MKN Marker Normal

Syntax

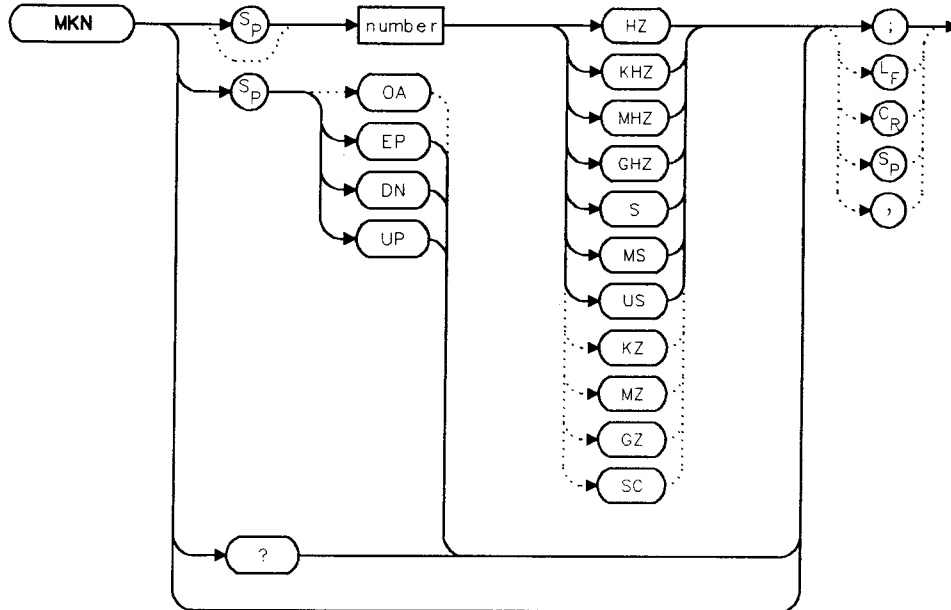

Description

The MKN command places an active marker on the specified frequency. If no frequency is specified, MKN places the marker at the center of the trace. When in zero span, querying MKN returns the center frequency.

Parameters

number real from 0 to 2.9E+9 (HP 8560A);
 0 to 6.5E+9 (HP 8561B);
 0 to 22E+9 (HP 8563A);
 0 to 26.5E+9 (HP 8563A Option 026);
 from 18E+9 to 325E+9 in external mixer mode.

UP/DN increments in 10% of span.

MKN Marker Normal

Query Response



Example

```
10 INPUT "ENTER IN THE START FREQUENCY, IN MHZ",Start_freq
20 INPUT "ENTER IN THE STOP FREQUENCY, IN MHZ",Stop_freq
30 OUTPUT 718;"IP;FA ";Start_freq;"MHZ"
40 OUTPUT 718;"FB ";Stop_freq;"MHZ;"
50 OUTPUT 718;"MKN EP;"
60 PRINT "PLACE THE MARKER ON THE DESIRED SIGNAL."
70 PRINT "PRESS HOLD, THEN PRESS CONTINUE."
80 PAUSE
90 OUTPUT 718;"MKN?;"
100 ENTER 718;Mkn
110 PRINT "MARKER FREQUENCY IS ",Mkn,"HZ"
120 END
```

MKNOISE Marker Noise

Syntax

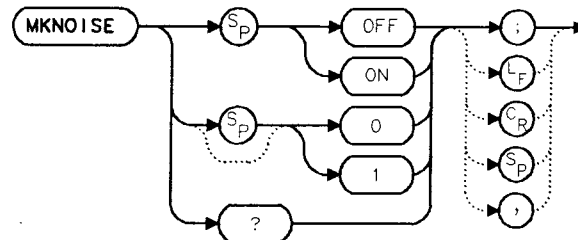

Description

MKNOISE sets the detector mode to sample and computes the average of 32 data points (16 points on one side of the marker, the marker itself, and 15 points on the other side of the marker). This average is corrected for effects of the log or linear amplifier, bandwidth shape, IF detector, and resolution bandwidth. If two markers are on (whether in marker delta mode or 1/marker delta mode), MKRNOISE works on the active marker and not on the anchor marker. This allows you to measure signal-to-noise density directly. To query the value, use the MKA command.

Query Response

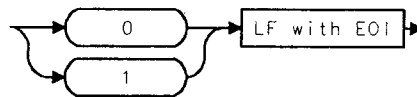

Example

```

10  OUTPUT 718;"CF 300MZ;SP 10MZ;DET SMP;TS;MKPK HI;MKA?;"
20  ENTER 718;Amp_1
30  OUTPUT 718;"MKD UP UP;MKNOISE ON;MKA?;MKNOISE OFF;"
40  ENTER 718;Amp_2
50  DISP Amp_2
60  C_to_n=Amp_1-Amp_2
70  PRINT "CARRIER TO NOISE RATIO IN 1 HZ BANDWIDTH IS
";C_to_n;" DB"
80  END

```

MKOFF

Marker Off

Syntax

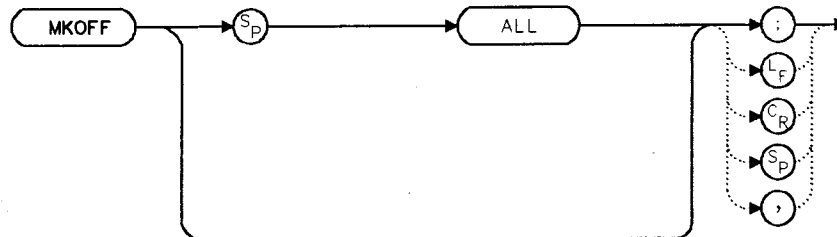

Description

The MKOFF command turns off the active marker or, if specified, turns off all markers.

Example

```
10  OUTPUT 718;"MKOFF ALL;"  
20  END
```

MKPK Peak Search

Syntax

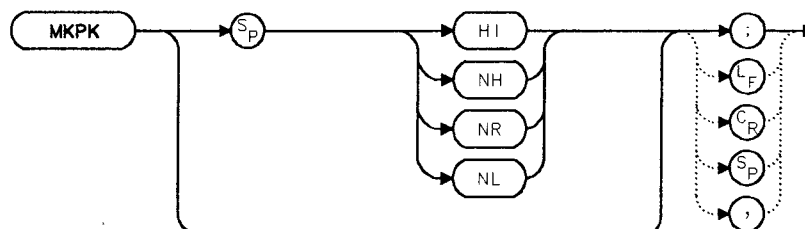

Description

The MKPK command places a marker on the highest point on a trace, the next-highest point, the next-left peak, or the next-right peak. The default is HI (highest point). The trace peaks must meet the criteria of the marker threshold and peak excursion functions in order for a peak to be found. See also the MKPT and MKPX commands.

Parameters

HI finds the highest point on a trace.
 NH finds the next-highest point on a trace.
 NR finds the next-right peak.
 NL finds the next-left peak.

Example

```

10  OUTPUT 718;"IP;SNGLS;"
20  INPUT "ENTER START FREQUENCY, IN MHZ",Start_freq
30  INPUT "ENTER STOP FREQUENCY, IN MHZ",Stop_freq
40  OUTPUT 718;"FA ";Start_freq;"MHZ;"
50  OUTPUT 718;"FB ";Stop_freq;"MHZ;"
60  OUTPUT 718;"TS;MKPK HI;MKD;MKPK NH;"
70  OUTPUT 718;"MKA?;"
80  ENTER 718;Delta_amplitude
90  OUTPUT 718;"MKF?;"
100 ENTER 718;Delta_freq
110 PRINT "DIFFERENCE IN FREQUENCY IS ",Delta_freq,"HZ"
120 PRINT "DIFFERENCE IN AMPLITUDE IS ",Delta_amplitude,"DB"
130 END
  
```

MKPT Marker Threshold

Syntax

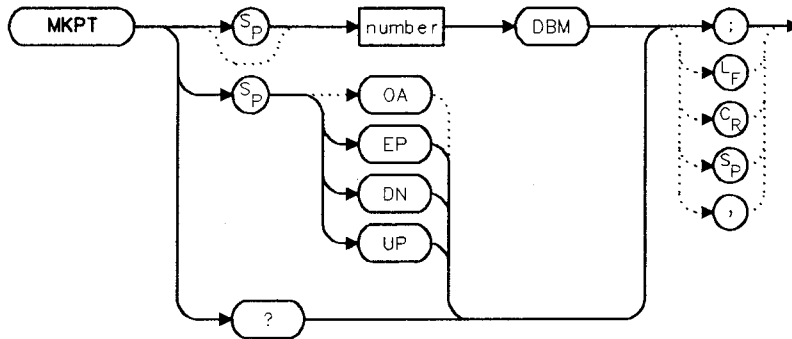

Description

The MKPT command sets the minimum amplitude level from which a peak on the trace can be detected. The default value is -130 dBm. See also the MKPX command.

Any portion of a peak that falls below the peak threshold is used to satisfy the peak excursion criteria. For example, a peak that is equal to 3 dB above the threshold when the peak excursion is equal to 6 dB will be found if the peak extends an additional 3 dB or more below the threshold level.

Parameters

number real from -200 to 30 .
UP/DN increments of 10 dB.

Query Response



Example

```
10  OUTPUT 718;"IP;SNGLS;"
20  INPUT "ENTER START FREQUENCY, IN MHZ",Start_freq
30  INPUT "ENTER STOP FREQUENCY, IN MHZ",Stop_freq
40  INPUT "ENTER IN MARKER THRESHOLD, IN DB",Thresh
50  OUTPUT 718;"FA ";Start_freq;"MHZ;"
60  OUTPUT 718;"FB ";Stop_freq;"MHZ;"
70  OUTPUT 718;"MKPT ";Thresh;"DBM;"
80  OUTPUT 718;"TS;MKPK HI;"
90  END
```

MKPX Peak Excursion

Syntax

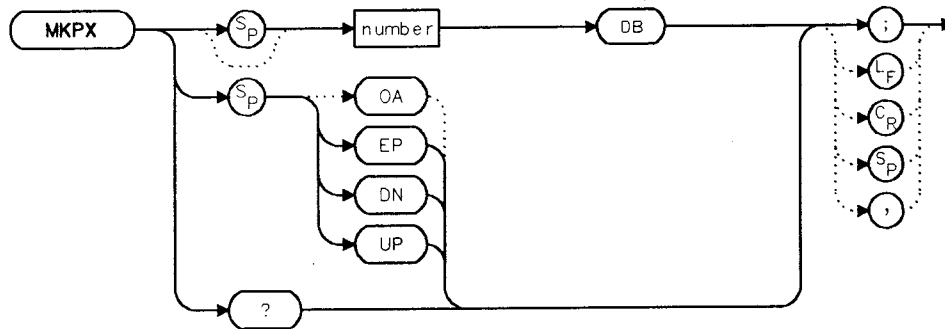

Description

The MKPX command defines what constitutes a peak on a trace. The chosen value specifies the amount that a trace must increase monotonically, then decrease monotonically, in order to be a peak. For example, if the peak excursion is 10 dB, the amplitude of the sides of a candidate peak must descend at least 10 dB in order to be considered a peak (see Figure 5-4). The default value is 6 dB. In linear mode, enter the marker peak excursion as a unit-less number of divisions.

Any portion of a peak that falls below the peak threshold is also used to satisfy the peak excursion criteria. For example, a peak that is equal to 3 dB above the threshold when the peak excursion is equal to 6 dB will be found if the peak extends an additional 3 dB or more below the threshold level.

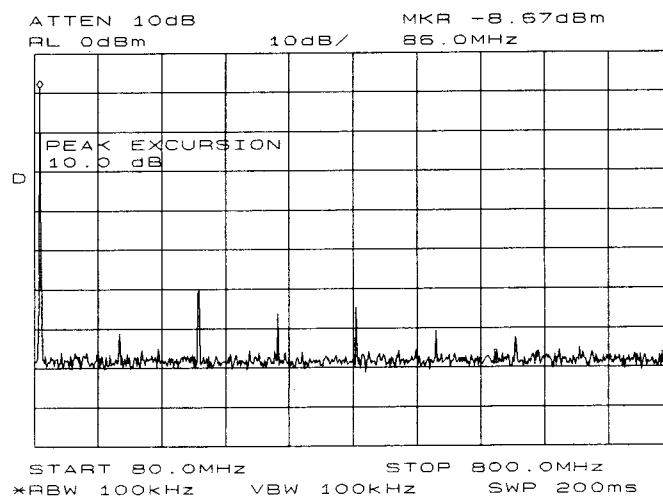

Figure 5-4. MKPX Determines Which Signals are Considered Peaks

Parameters

number real from 0.1 to 10 in linear mode; 0 to 30 in log mode.
 UP/DN 1 vertical division of the display.

Query Response**Example**

```

10  OUTPUT 718;"IP;FA 250MHZ;FB 1300MHZ;"
20  INPUT "ENTER IN PEAK EXCURSION, IN DB ",Excursion
30  OUTPUT 718;"MKPX ";Excursion;"DB;"
40  OUTPUT 718;"TS;MKPK HI;MKA?;"
50  ENTER 718;Mka
60  OUTPUT 718;"MKF?;"
70  ENTER 718;Mkf
80  PRINT "PEAK FOUND AT ",Mkf
90  PRINT "PEAK AMPLITUDE IS",Mka
100 END

```

MKRL Marker to Reference Level

Syntax

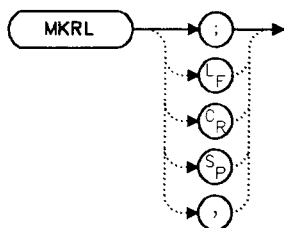

Description

The MKRL command sets the reference level to the amplitude of an active marker. If no marker is active, MKRL places a marker at the center of the trace and uses that marker amplitude to set the reference level. This command is not available when in delta marker mode.

Example

```
10  OUTPUT 718;"IP;SNGLS;CF 300MHZ;SP 20MHZ;"
20  OUTPUT 718;"TS;MKPK HI;MKRL;TS;"
30  OUTPUT 718;"RL?;AUNITS?;"
40  ENTER 718 USING "K";Ref_level,Aunits$
50  PRINT "REFERENCE LEVEL IS",Ref_level,Aunits$
60  END
```

MKSP Marker Delta to Span

Syntax

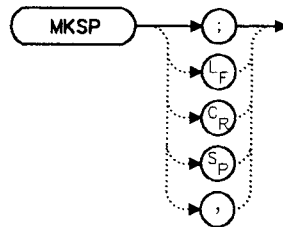

Description

The MKSP command sets the frequency span equal to the frequency difference between two markers on a trace. The start frequency is set equal to the frequency of the left-most marker and the stop frequency is set equal to the frequency of the right-most marker.

Example

```

10  INPUT "CONNECT THE 300 MHZ CALIBRATOR TO THE INPUT",Ans$
20  OUTPUT 718;"IP;SNGLS;FA 270MHZ;FB 1275MHZ;TS;"
30  OUTPUT 718;"MKPK HI;MKD;MKPK NH;TS;MKSP;TS;"
40  END

```

MKSS

Marker to Center Frequency Step-Size

Syntax

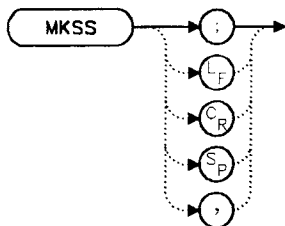

Description

The MKSS command sets the center frequency step-size equal to the frequency value of the active marker.

Example

```
10 INPUT "CONNECT THE 300 MHZ CALIBRATOR TO THE INPUT",Ans$
20 OUTPUT 718;"IP;SNGLS;CF 300MHZ;SP 20MHZ;TS;"
30 OUTPUT 718;"MKPK HI;MKSS;MKD;CF UP;TS;MKPK HI;"
40 OUTPUT 718;"MKA?;"
50 ENTER 718;Delta_amplitude
60 OUTPUT 718;"MKF?;"
70 ENTER 718;Delta_freq
80 PRINT "DIFFERENCE IN AMPLITUDE IS",Delta_amplitude,"DB"
90 PRINT "DIFFERENCE IN FREQUENCY IS ",Delta_freq,"HZ"
100 END
```

MKT Marker Time

Syntax

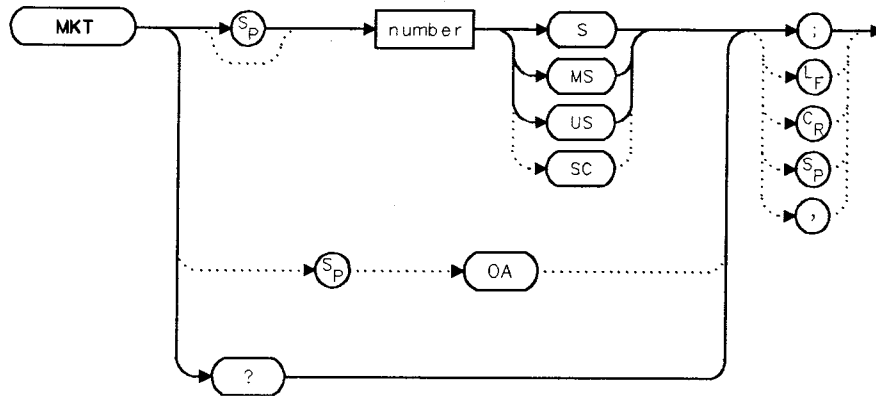

Description

The MKT command places a marker at a position that corresponds to a specified point in time during the sweep. Default units are seconds.

Parameter

number real from 0 to the current sweep time.

Preset State

Off

Query Response

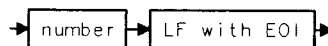

Example

```
10  OUTPUT 718;"ST 2S;MKT 1.6S;"
20  END
```

MKTRACK

Signal Track

Syntax

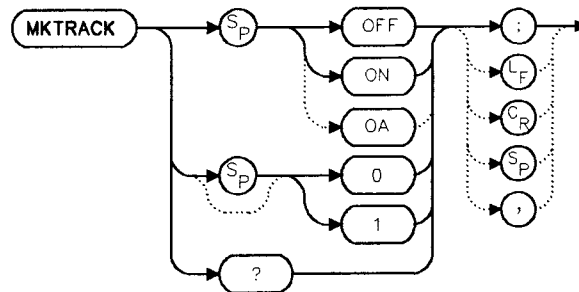

Description

The MKTRACK command locates the active marker and sets the center frequency to the marker value. This is done after every sweep, thus maintaining the marker value at the center frequency. This allows you to “zoom in” quickly from a wide span to a narrow one, without losing the signal from the screen. Or, use MKTRACK to keep a slowly drifting signal centered on the display. When this function is active, a K appears on the left edge of the display.

Preset State

Off

Query Response

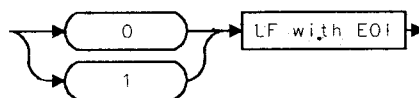

Example

```
10 INPUT "ENTER IN CENTER FREQUENCY, IN MHZ",Freq
20 INPUT "ENTER IN FREQUENCY SPAN, IN MHZ",Span
30 OUTPUT 718;"IP;"
40 OUTPUT 718;"CF ";Freq;"MHZ;TS;"
50 OUTPUT 718;"MKTRACK ON;"
60 OUTPUT 718;"SP ";Span;"MHZ;TS;"
70 OUTPUT 718;"MKTRACK OFF;"
80 END
```

ML Mixer Level

Syntax

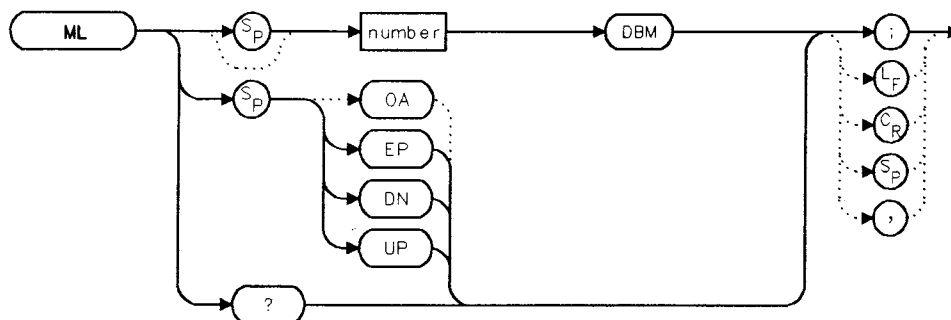

Description

The ML command specifies the maximum signal level that is at the input mixer. The attenuator automatically adjusts to ensure that this level is not exceeded for signals less than the reference level.

Parameters

number integer from -80 to -10 , in decade increments. Numbers round down to the nearest decade.
UP/DN increments by 10 dB.

Preset State

-10 dBm

Query Response

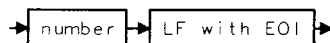

Example

```

10  OUTPUT 718;"ML -40DBM;"
20  OUTPUT 718;"ML?;"
30  ENTER 718;M1
40  PRINT M1
50  END

```

MXMH

Maximum Hold

Syntax

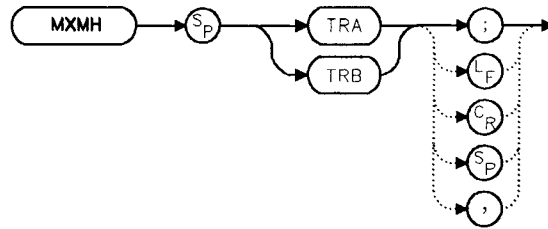

Description

The MXMH command updates the chosen trace with the maximum signal level detected at each trace-data point from subsequent sweeps. This function employs the positive peak detector (refer to the DET command). The detector mode can be changed, if desired, after max hold is initialized.

Example

```
10 OUTPUT 718;"BLANK TRA;CLRW TRB;MXMH TRB;"  
20 END
```

MXRMODE Mixer Mode

Syntax

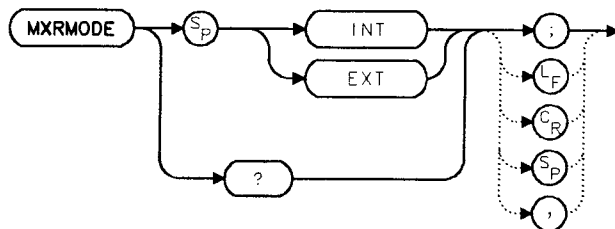

Description

The MXRMODE command specifies the mixer mode. Select either the internal mixer (INT) or supply an external mixer (EXT). This command does not apply to an HP 8560A Option 002.

Preset State

Internal

Query Response

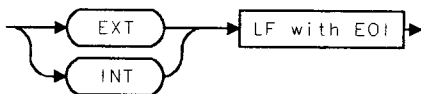

Example

```

10 INPUT "ENTER THE MIXER MODE (INT OR EXT)",Mode$
20 OUTPUT 718;"MXRMODE ";Mode$;" "
30 END

```

NORMLIZE

Normalize Trace Data

Syntax

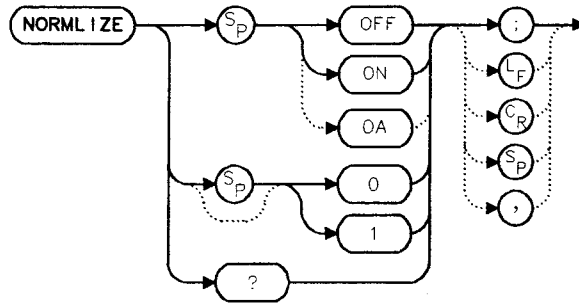

Description

The `NORMLIZE` command activates or deactivates the normalization routine for stimulus-response measurements. This function subtracts trace B from trace A, offsets the result by the value of the normalized reference position (NRL), and displays the result in trace A. `NORMLIZE` is intended for use with the `STOREOPEN` and `STORESHORT` or `STORETHRU` commands. These functions are used to store a reference trace into trace B. Refer to the respective command descriptions for more information.

Accurate normalization occurs only if the reference trace and the measured trace are on-screen. If any of these traces are off-screen, an error message will be displayed. If the error message `ERR 903 A > DLMT` is displayed, the range level (RL) can be adjusted to move the measured response within the displayed measurement range of the analyzer. If `ERR 904 B > DLMT` is displayed, the calibration is invalid and a thru or open/short calibration must be performed.

If active (ON), the `NORMLIZE` command is automatically turned off with an instrument preset (IP) or at power on.

Preset State

Off

Query Response

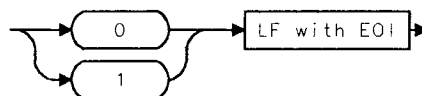

Example

The following example is for use with an HP 8560A Option 002 only.

```
10  OUTPUT 718;"IP;SNGLS;"
20  OUTPUT 718;"FA 300KHZ;FB 1GHZ;"
30  OUTPUT 718;"SRCPWR ON;"
40  OUTPUT 718;"SWPCPL SR;"
50  OUTPUT 718;"RB 100KHZ;"
60  OUTPUT 718;"SRCTKPK;DONE?;"
70  ENTER 718;Done
80  PRINT "CONNECT THRU. PRESS CONTINUE WHEN READY TO STORE."
90  PAUSE
100 OUTPUT 718;"TS;DONE?;"
110 ENTER 718;Done
120 OUTPUT 718;"STORETHRU;"
130 OUTPUT 718;"TS;DONE?;"
140 ENTER 718;Done
150 OUTPUT 718;"NORMLIZE ON;"
160 OUTPUT 718;"TS;DONE?;"
170 ENTER 718;Done
180 LOCAL 718
190 END
```

NRL

Normalized Reference Level

Syntax

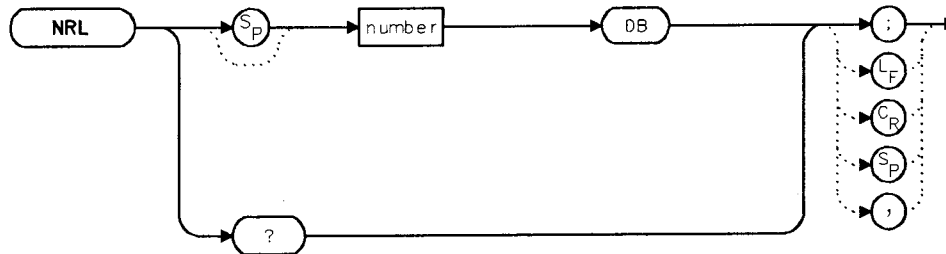

Description

The NRL command sets the normalized reference level. It is intended to be used with the NORMLIZE command. When using NRL, the input attenuator and IF step gains are not affected. This function is a trace-offset function enabling the user to offset the displayed trace without introducing hardware-switching errors into the stimulus-response measurement. The unit of measure for NRL is dB.

In absolute power mode (dBm), reference level (RL) affects the gain and RF attenuation settings of the instrument, which affects the measurement or dynamic range. In normalized mode (relative power or dB-measurement mode), NRL offsets the trace data on-screen and does not affect the instrument gain or attenuation settings. This allows the displayed normalized trace to be moved without decreasing the measurement accuracy due to changes in gain or RF attenuation. If the measurement range must be changed to bring trace data on-screen, then the *range level* (see RL) should be adjusted. Adjusting the range-level in normalized mode has the same effect on the instrument settings as does reference level in absolute power mode (normalize off).

Parameters

number real from -100 to +100.

Preset State

0 dB

Query Response

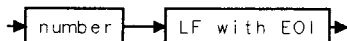

Example

The following example is for use with an HP 8560A Option 002.

```

10  OUTPUT 718;"IP;SNGLS;"
20  OUTPUT 718;"FA 300KHZ;FB 1GHZ;"
30  OUTPUT 718;"SRCPWR ON;"
40  OUTPUT 718;"SWPCPL SR;"
50  OUTPUT 718;"SRCTKPK;DONE?;"
60  ENTER 718;Done
70  PRINT "CONNECT THRU.  PRESS CONTINUE WHEN READY TO STORE."
80  PAUSE
90  OUTPUT 718;"TS;DONE?;"
100 ENTER 718;Done
110 OUTPUT 718;"STORETHRU;"
120 OUTPUT 718;"TS;DONE?;"
130 ENTER 718;Done
140 OUTPUT 718;"NORMLIZE ON;"
150 OUTPUT 718;"TS;DONE?;"
160 ENTER 718;Done
170 OUTPUT 718;"NRPOS 5;TS;"
180 PRINT "RECONNECT DUT.  PRESS CONTINUE WHEN READY."
190 PAUSE
200 OUTPUT 718;"NRL -10DB;"
210 OUTPUT 718;"TS;DONE?;"
220 ENTER 718;Done
230 LOCAL 718
240 END

```

NRPOS

Normalized Reference Position

Syntax

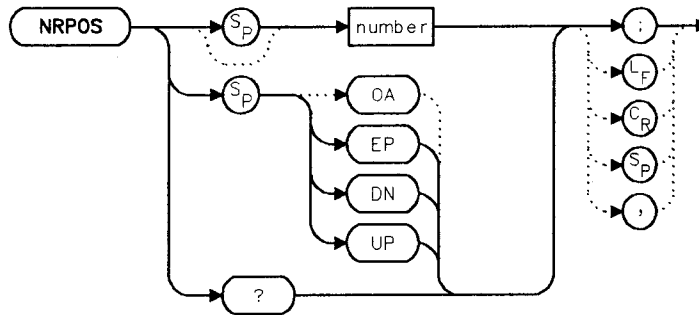

Description

The NRPOS command adjusts the normalized reference-position that corresponds to the position on the graticule where the difference between the measured and calibrated traces resides. The dB value of the normalized reference-position is equal to the normalized reference level. The normalized reference-position may be adjusted between 0.0 and 10.0, corresponding to the bottom and top graticule lines, respectively.

Parameters

number real from 0.0 to 10.0.
 UP/DN increments by 1.0.

Preset State

10.0 (top graticule line)

Query Response



Example

The following example is for use with an HP 8560A Option 002 only.

```
10  OUTPUT 718;"IP;SNGLS;"
20  OUTPUT 718;"FA 300KHZ;FB 1GHZ;"
30  OUTPUT 718;"SRCPWR ON;"
40  OUTPUT 718;"SWPCPL SR;"
50  OUTPUT 718;"SRCTKPK;DONE?;"
60  ENTER 718;Done
70  PRINT "CONNECT THRU.  PRESS CONTINUE WHEN READY TO STORE."
80  PAUSE
90  OUTPUT 718;"TS;DONE?;"
100 ENTER 718;Done
110 OUTPUT 718;"STORETHRU;"
120 OUTPUT 718;"TS;DONE?;"
130 ENTER 718;Done
140 OUTPUT 718;"NORMLIZE ON;"
150 OUTPUT 718;"TS;DONE?;"
160 ENTER 718;Done
170 OUTPUT 718;"NRPOS 5;TS;"
180 PRINT "RECONNECT DUT.  PRESS CONTINUE WHEN READY."
190 PAUSE
200 OUTPUT 718;"NRL -10DB;"
210 OUTPUT 718;"TS;DONE?;"
220 ENTER 718;Done
230 LOCAL 718
240 END
```

OP

Output Display Parameters

Syntax

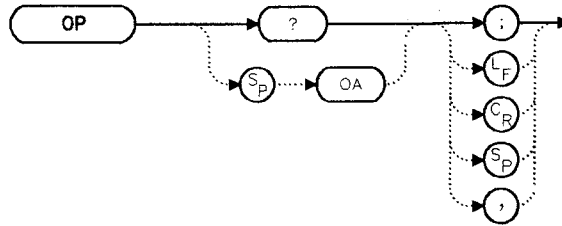

Description

The OP command requests the location of the lower left (P1) and upper right (P2) vertices of the display window.

Query Response

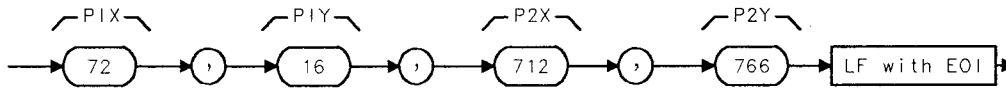

Example

```
10  OUTPUT 718;"OP?;"  
20  ENTER 718;X$  
30  PRINT X$  
40  END
```

PLOT Plot Display

Syntax

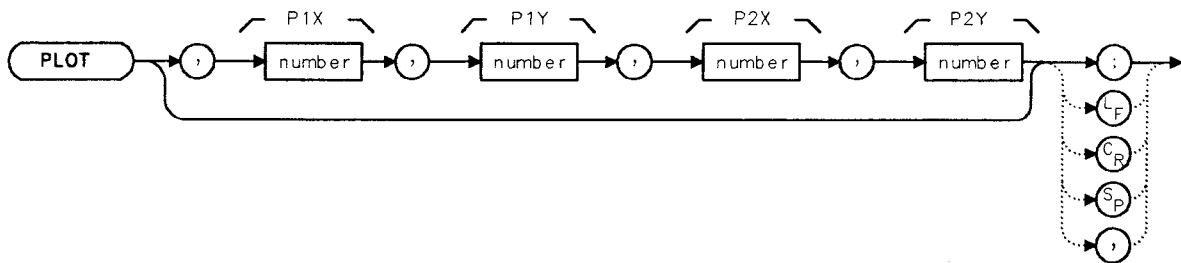

Description

The PLOT command copies the specified display contents onto any HP-GL plotter. Set the plotter address to 5, select the P1 and P2 positions, and then execute the plot command. P1 and P2 correspond to the lower-left and upper-right plotter positions, respectively. If P1 and P2 are not specified, default values (either preloaded from power-up or sent in via a previous plot command) are used. Once PLOT is executed, no subsequent commands are executed until PLOT is done. For more information, refer to Chapter 4.

Parameters

P1X, P1Y plotter-dependent values that specify the lower-left plotter position.
P2X, P2Y plotter-dependent values that specify the upper-right plotter position.

Example

```

10  OUTPUT 705;"0P;"
20  ENTER 705;P1x,P1y,P2x,P2y
30  ON INTR 7 GOTO Done
40  ENABLE INTR 7;2
50  OUTPUT 718;"PLOT ";P1x;",";P1y;",";P2x;",";P2y;";"
60  OUTPUT 718;"RQS 16;"
70  SEND 7;UNL LISTEN 5 TALK 18 DATA
80  Idle:  GOTO Idle
90  Done:  S_poll=SPOLL(718)
100         OUTPUT 718;"RQS 0;"
110         PRINT "COMMAND IS COMPLETE"
120  END

```

PLOTORG

Display Origins

Syntax

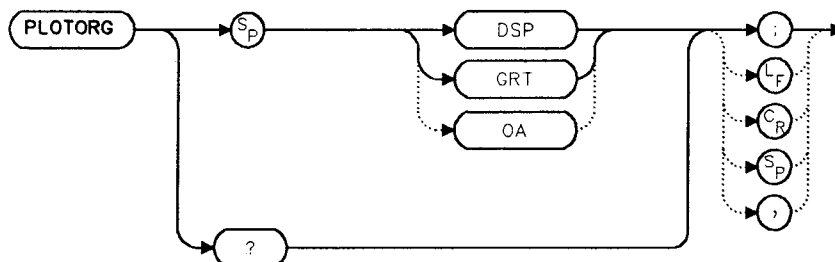

Description

The PLOTORG command specifies whether the P1 and P2 plotter settings are the origin for the display graticule or for the entire display. GRT allows you to position the output plot, such as trace A, on a preprinted graticule (obtained from the PLTSRC command) and to save plotting time. For more information on P1 and P2 settings, see the PLOT command, or refer to Chapter 4.

Parameters

DSP references P1 and P2 to the corners of the entire display.
GRT references P2 and P2 to the corners of the graticule.

Query Response

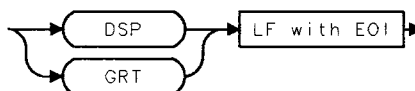

Example

```
10 OUTPUT 705;"OP;"
20 ENTER 705;P1x,P1y,P2x,P2y
30 OUTPUT 718;"PLOTORG GRT;"
40 OUTPUT 718;"PLOT ";P1x,"";P1y,"";P2x,"";P2y;"
50 SEND 7;UNL LISTEN 5 TALK 18 DATA
60 END
```

PLOTSRC Plot Source

Syntax

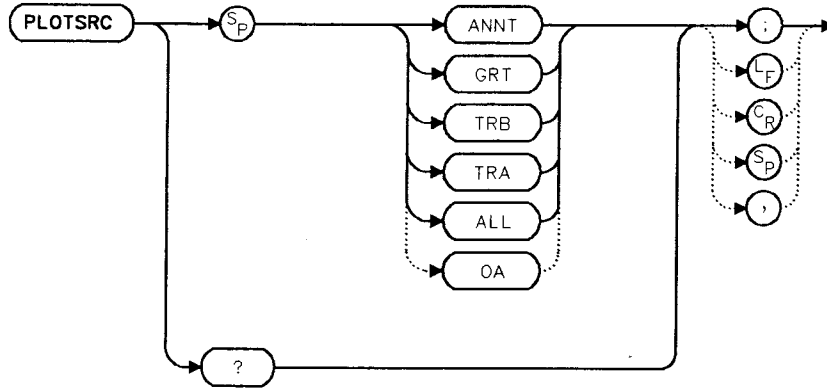

Description

The PLOTSRC command specifies the source for the PLOT command.

Parameters

- ALL plots the entire display.
- TRA plots only trace A.
- TRB plots only trace B.
- GRT plots only the graticule.
- ANNT plots only the annotation.

Preset State

All

Query Response

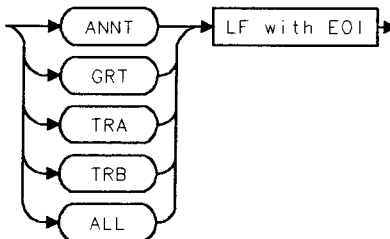

PLOTSRC Plot Source

Example

```
10  OUTPUT 705;"OP;"
20  ENTER 705;P1x,P1y,P2x,P2y
30  OUTPUT 718;"PLOTSRC TRA;RQS 16;PLOT
";P1x;"";P1y;"";P2x;"";P2y;"RQS 0;"
40  Done=0
50  IF Done=0 THEN GOSUB Wait_plot
60  Done=0
70  OUTPUT 718;"PLOTSRC ANNT;RQS 16;PLOT
";P1x;"";P1y;"";P2x;"";P2y;"RQS 0;"
80  IF Done=0 THEN GOSUB Wait_plot
90  PRINT "COMMAND IS COMPLETE"
100 STOP
110 Wait_plot: Done=1
120         ON INTR 7 GOTO Go_back
130         ENABLE INTR 7;2
140         SEND 7;UNL LISTEN 5 TALK 18 DATA
150 Idle:   GOTO Idle
160 Go_back: S_poll=SPOLL(718)
170         RETURN
180 END
```

PP Preselector Peak

Syntax

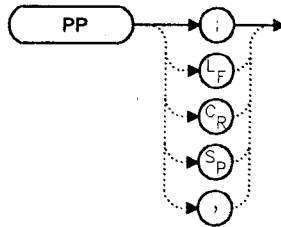

Description

The PP command peaks the preselector in the HP 8561B and HP 8563A Spectrum Analyzers. Make sure the entire frequency span is in high band, set the desired trace to clear-write mode, place a marker on a desired signal, then execute PP. The peaking routine zooms to zero span, peaks the preselector tracking, then returns to the original position. To read the new preselector peaking number, use the PSDAC command. Commands following PP are not executed until after the analyzer has finished peaking the preselector.

Note

The PP command is not available remotely on an HP 8560A with preselected external mixers.



Example

```
10  OUTPUT 718;"CF 3GHZ;SP 500KHZ;"
20  OUTPUT 718;"TS;MKPK HI;MKCF;TS;PP;"
30  END
```

PRINT

Print

Syntax

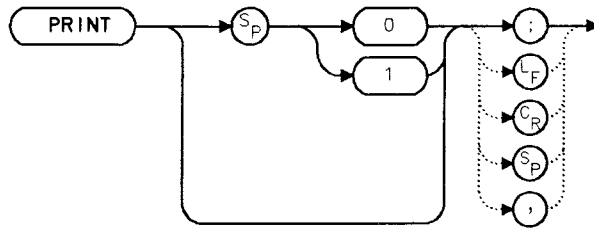

Description

The PRINT command initiates an output of the screen data to the remote interface. With appropriate HP-IB commands, the HP-IB can be configured to route the data to an external printer. The data is output in HP raster graphics format. PRINT or PRINT 0 produces a monochrome printout. PRINT 1 produces a “color format” output, if an HP PaintJet printer is used.

The PRINT command must be followed by the program line listed below with the correct values added in place of the variables:

```
SEND Sel_code; UNT UNL LISTEN Prt_addr TALK Sa_addr DATA
```

where:	Sel_code is the interface select code
	Prt_addr is the printer's address on that select code
	Sa_addr is the analyzer's address on that select code

Parameters

- 0: monochrome output
- 1: color format output

Example

```
10  OUTPUT 718;"IP;"
20  OUTPUT 718;"CF 300MHZ;SP 1MHZ;TS;DONE?;"
30  ENTER 718;Done
40  ON INTR 7 GOTO Finish
50  ENABLE INTR 7;2
60  OUTPUT 718;"PRINT 0;RQS 16;"
70  SEND 7;UNT UNL LISTEN 1 TALK 18 DATA
80  Idle:  GOTO Idle
90  Finish: S_poll=SPOLL(718)
100         OUTPUT 718;"RQS 0;"
110 PRINT "PRINT IS COMPLETE"
120 END
```

PSDAC

Preselector DAC Number

Syntax

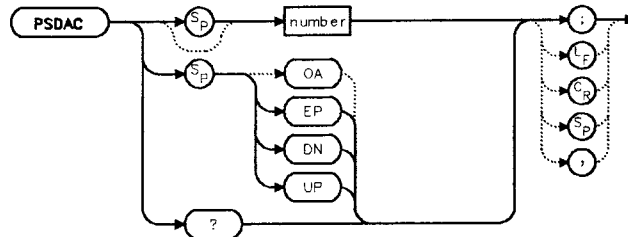

Description

The PSDAC command adjusts or returns the preselector peak DAC number. For use with HP 8561B and HP 8563A Spectrum Analyzers.

When setting PSDAC to a given value, the hardware is not set until the end of the sweep. Therefore, trace data does not reflect the current instrument hardware settings until another TS command is done.

Note

The PSDAC command is not available remotely on an HP 8560A with preselected external mixers.



Parameters

number integer from 0 to 255.
UP/DN increments of 1.

Query Response



Example

```
10  OUTPUT 718;"CF 3GHZ;SP 500KHZ;"
20  OUTPUT 718;"TS;MKPK HI;MKCF;TS;PP;"
30  OUTPUT 718;"PSDAC?;"
40  ENTER 718;Dac_number
50  PRINT "PRESELECTOR DAC NUMBER IS",Dac_number
60  END
```

PSTATE Protect State

Syntax

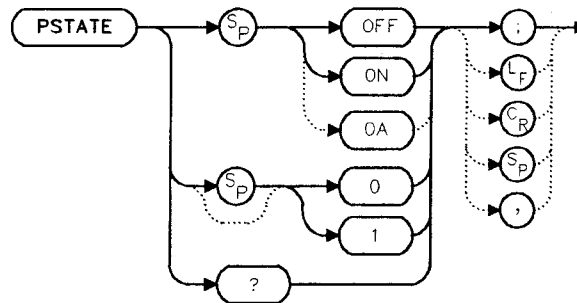

Description

The PSTATE command prevents storing any new data in the state or trace registers. When PSTATE is on, the registers are “locked”; the data in them cannot be erased or overwritten, although the data can be recalled. To “unlock” the registers, and store new data, set PSTATE to off by selecting 0 or OFF as the parameter.

Preset State

Off

Query Response

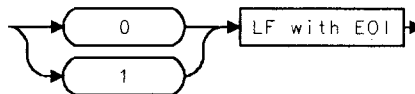

Example

```

10  OUTPUT 718;"PSTATE ON;"
20  OUTPUT 718;"PSTATE?;"
30  ENTER 718;State
40  PRINT State
50  OUTPUT 718;"PSTATE OFF;"
60  END
  
```

PWRBW

Trace Power Bandwidth

Syntax

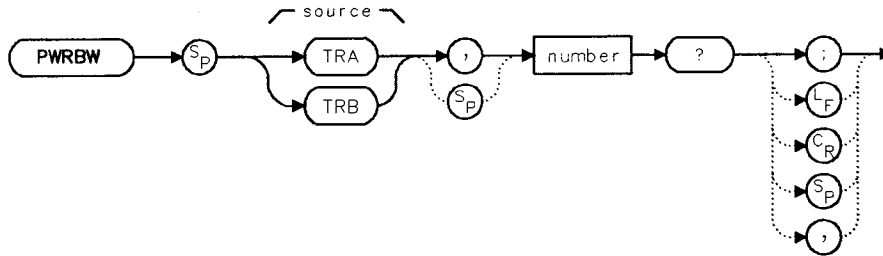

Description

The PWRBW command first computes the combined power of all signal responses contained in a trace array. The command then computes the bandwidth equal to a percentage of the total power.

For example, if 100% is specified, the power bandwidth equals the current frequency span. If 50% is specified, trace elements are eliminated from either end of the array, until the combined power of the remaining trace elements equals half of the total power computed. The frequency span of these remaining trace elements is the power bandwidth output to the controller.

Parameter

number real from 1 to 100.

Query Response



Example

```

10  DISP "CONNECT CAL OUT TO INPUT"
20  OUTPUT 718;"IP;"
30  OUTPUT 718;"SNGLS;"
40  OUTPUT 718;"CF 300MHZ;SP 1MHZ;RB 300KHZ;"
50  OUTPUT 718;"MXMH TRA;TS;TS;TS;TS;"
60  OUTPUT 718;"PWRBW TRA, 99.0?;"
70  ENTER 718;P
80  DISP "THE POWER BANDWIDTH AT 99 PERCENT IS";P/1.0E+3;"kHz"
90  END

```

RB Resolution Bandwidth

Syntax

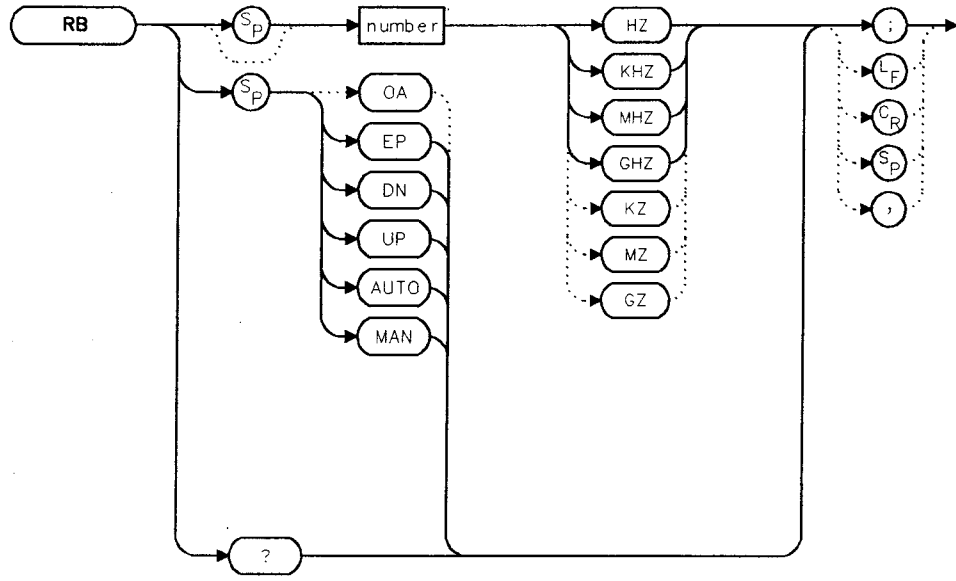

Description

The RB command sets the resolution bandwidth. This is normally a coupled function that is selected by the span setting according to the ratio selected by the RBR command. If no ratio is selected, a default ratio (0.011) is used. The bandwidth, which ranges from 10 Hz to 2 MHz, may also be selected manually.

Parameters

- number integer from 10 to 2E+6. Numbers are rounded to the nearest bandwidth.
- UP/DN increments in a 1, 3, 10 sequence.

Preset State

Coupled mode, 1 MHz

Query Response



RB Resolution Bandwidth

Example

```
10  OUTPUT 718;"IP;"
20  OUTPUT 718;"CF 1.2GHZ;SP 2GHZ;"
30  INPUT "SELECT THE RESOLUTION BANDWIDTH, IN KHZ",B_width
40  OUTPUT 718;"RB ";B_width;"KHZ;"
50  OUTPUT 718;"RB?;"
60  ENTER 718;B_width
70  PRINT "SELECTED BANDWIDTH IS ",B_width,"KHZ"
80  END
```

RBR Resolution Bandwidth to Span Ratio

Syntax

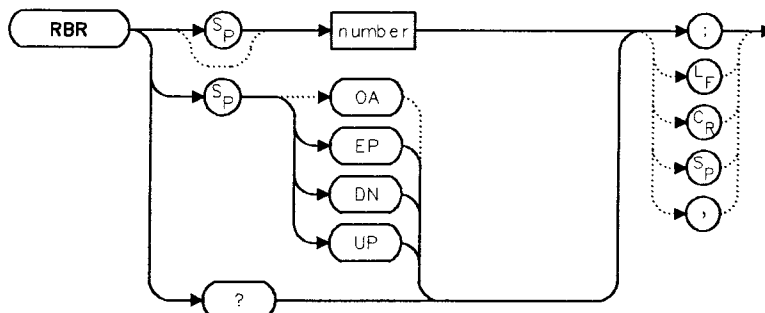

Description

The RBR command specifies the coupling ratio between the resolution bandwidth and the frequency span. When the frequency span is changed, the resolution bandwidth is changed to satisfy the selected ratio.

Parameters

number real from 0.002 to 0.10.
UP/DN increments in a 1, 2, 5 sequence.

Preset State

0.011

Query Response



Example

```

10  OUTPUT 718;"IP;"
20  OUTPUT 718;"CF 1.2GHZ;SP 200MHZ;"
30  INPUT "SELECT THE RESOLUTION BANDWIDTH TO SPAN RATIO",B_ratio
40  OUTPUT 718;"RBR ";B_ratio;";"
50  OUTPUT 718;"RB?;"
60  ENTER 718;B_width
70  PRINT "SELECTED BANDWIDTH IS ",B_width,"KHZ"
80  END
  
```

RCLOSCAL

Recall Open/Short Average

Syntax

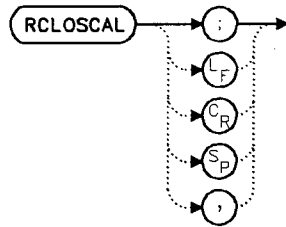

Description

The RCLOSCAL command recalls the internally stored open/short average reference trace into trace B. The instrument state is also set to the stored open/short reference state.

Example

The following example applies only to an HP 8560A Option 002. However, the RCLOSCAL command may be used on the HP 8560A, HP 8561B, or HP 8563A with an HP 85640A Tracking Generator.

```
10  OUTPUT 718;"IP;SNGLS;"
20  OUTPUT 718;"FA 300 KHZ;FB 1GHZ;"
30  OUTPUT 718;"SRCPWR ON;"
40  OUTPUT 718;"SWPCPL SR;"
50  OUTPUT 718;"SRCTKPK;DONE?;"
60  ENTER 718;Done
70  PRINT "CONNECT OPEN.  PRESS CONTINUE WHEN READY TO STORE."
80  PAUSE
90  OUTPUT 718;"TS;DONE?;"
100 ENTER 718;Done
110 OUTPUT 718;"STOREOPEN;TS;DONE?;"
120 ENTER 718;Done
130 PRINT "CONNECT SHORT.  PRESS CONTINUE WHEN READY
      TO STORE AND AVERAGE."
140 PAUSE
150 OUTPUT 718;"STORESHORT;TS;DONE?;"
160 ENTER 718;Done
170 PRINT "RECONNECT DUT.  PRESS CONTINUE WHEN READY."
180 PAUSE
190 OUTPUT 718;"NORMLIZE ON;"
200 OUTPUT 718;"TS;DONE?;"
210 ENTER 718;Done
220 OUTPUT 718;"NRPOS 8;TS;"
230 !demonstrate recall of open/short average trace
240 OUTPUT 718;"IP;"
```

RCLOSCAL Recall Open/Short Average

```
250 OUTPUT 718;"RCLOSCAL;TS;DONE?;"
260 ENTER 718;Done
270 !instrument state is returned to calibrated state
280 OUTPUT 718;"NORMLIZE ON;"
290 OUTPUT 718;"TS;DONE?;"
300 ENTER 718;Done
310 OUTPUT 718;"NRPOS 8;"
320 OUTPUT 718;"TS;DONE?;"
330 !end recall
340 LOCAL 718
350 END
```

RCLS

Recall State

Syntax

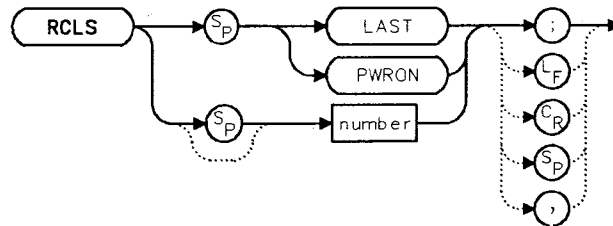

Description

The RCLS command recalls to the display a previously saved instrument state. See SAVES.

Parameters

- number integer from 0 to 9. Numbers less than zero default to zero; numbers greater than nine default to nine.
- LAST recalls the instrument state that existed previous to executing the IP command or switching **LINE** off.
- PWR ON sets the instrument state to the same state that occurred when **LINE** was switched on. This state was originally saved using the SAVES command.

Example

```
10 OUTPUT 718;"SAVES 7;"
20 OUTPUT 718;"IP;"
30 OUTPUT 718;"RCLS 7;"
40 END
```

RCLT Recall Trace

Syntax

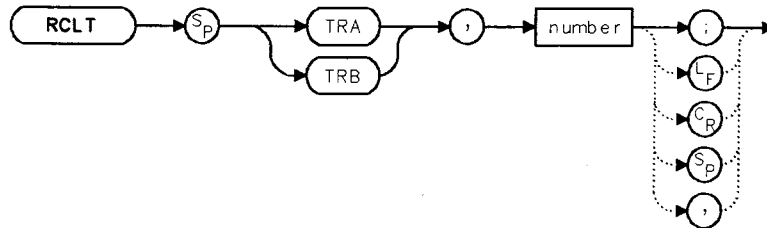

Description

The RCLT command recalls previously saved trace data to the display. See SAVET.

Parameters

TRA recalls the trace data to trace A.
 TRB recalls the trace data to trace B.
 number integer from 0 to 7. Numbers less than zero default to zero; numbers greater than seven default to seven.

Example

```

10  OUTPUT 718;"IP;CF 300MHZ;SP 20MHZ;"
20  OUTPUT 718;"SAVET TRA,7;"
30  OUTPUT 718;"IP;"
40  OUTPUT 718;"RCLT TRB,7;"
50  END

```

RCLTHRU

Recall Thru

Syntax

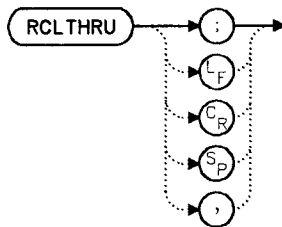

Description

The RCLTHRU command recalls the internally stored thru-reference trace into trace B. The instrument state is also set to the stored thru-reference state.

Example

The following example applies only to an HP 8560A Option 002. However, the RCLOSCAL command may be used on the HP 8560A, HP 8561B, or HP 8563A with an HP 85640A Tracking Generator.

```
10  OUTPUT 718;"IP;SNGLS;"
20  OUTPUT 718;"FA 300 KHZ;FB 1GHZ;"
30  OUTPUT 718;"SRCPWR ON;"
40  OUTPUT 718;"SWPCPL SR;"
50  OUTPUT 718;"SRCTKPK;DONE?;"
60  OUTPUT 718;"ENTER 718;Done
70  PRINT "CONNECT THRU.  PRESS CONTINUE WHEN READY TO STORE."
80  PAUSE
90  OUTPUT 718;"TS;DONE?;"
100 ENTER 718;Done
110 OUTPUT 718;"STORETHRU;TS;DONE?;"
120 ENTER 718;Done
130 PRINT "RECONNECT DUT.  PRESS CONTINUE WHEN READY."
140 PAUSE
150 OUTPUT 718;"NORMLIZE ON;"
160 OUTPUT 718;"TS;DONE?;"
170 ENTER 718;Done
180 OUTPUT 718;"NRPOS 8;TS;"
190 PAUSE
200 !demonstrate recall of thru trace
210 OUTPUT 718;"IP;"
220  OUTPUT 718;"RCLTHRU;TS;DONE?;"
230  ENTER 718;Done
240  !instrument state is returned to calibrated state
250  OUTPUT 718;"NORMLIZE ON;"
```

RCLTHRU Recall Thru

```
260 OUTPUT 718;"TS;DONE?;"
270 ENTER 718;Done
280 OUTPUT 718;"NRPOS 8;"
290 OUTPUT 718;"TS;DONE?;"
300 ENTER 718;Done
310 !end recall
320 LOCAL 718
330 END
```

REV

Revision Number

Syntax

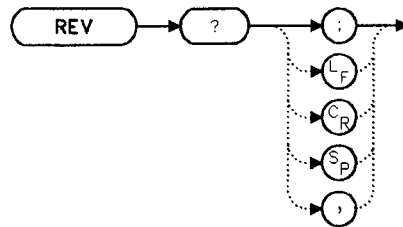

Description

The REV command sends to the computer the revision date code of the spectrum analyzer firmware.

Query Response

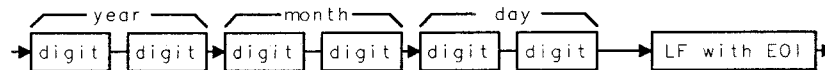

Example

```
10 DIM A$[6]
20 OUTPUT 718;"REV?;"
30 ENTER 718;A$
40 PRINT A$
50 END
```

RL Reference/Range Level

Syntax

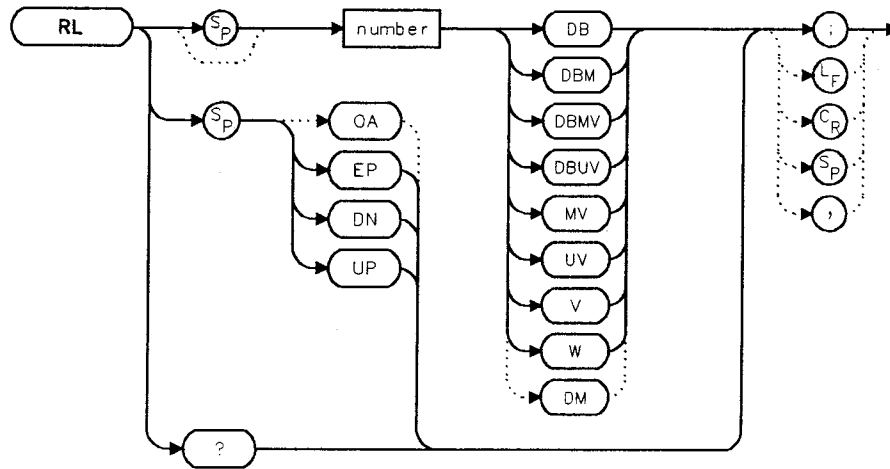

Description

The RL command sets the reference level, or range level when in normalized mode. (Range level functions the same as reference level.) The reference level is the top horizontal line on the graticule. For best measurement accuracy, place the peak of a signal of interest on the reference-level line. The spectrum analyzer input attenuator is coupled to the reference level and automatically adjusts to avoid compression of the input signal. Table 5-6 shows the minimum reference level for each band and amplitude scale. Refer also to AUNITS.

RL Reference/Range Level

Table 5-6.
Frequency Ranges and Minimum Reference Level (0 dB Input Attenuation)

Band	Minimum Reference Level	
	Log Scale	Linear Scale
HP 8560A: 50 Hz to 2.9 GHz	-120.0 dBm	2.2 μ V
HP 8561B: 50 Hz to 2.9 GHz	-120.0 dBm	2.2 μ V
2.75 GHz to 6.5 GHz	-120.0 dBm	2.2 μ V
HP 8563A: 50 Hz to 2.9 GHz	-120.0 dBm	2.2 μ V
2.75 GHz to 6.46 GHz	-120.0 dBm	2.2 μ V
5.86 GHz to 13.0 GHz	-115.0 dBm	4.0 μ V
12.4 GHz to 19.7 GHz	-105.0 dBm	12.6 μ V
19.7 GHz to 22.0 GHz	-100.0 dBm	22 μ V

Parameters

number dependent on the chosen amplitude units.
UP/DN increments by one vertical division in log mode, and in a 1, 2, 5, 10 sequence in linear mode.

Query Response

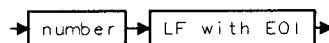

Preset State

0 dBm

Example

```
10 OUTPUT 718;"IP;SNGLS;CF 300MHZ;SP 20MHZ;"
20 OUTPUT 718;"TS;MKPK HI;MKRL;TS;"
30 OUTPUT 718;"RL?;"
40 ENTER 718;Ref_level
50 PRINT "REFERENCE LEVEL IS",Ref_level,"DB"
60 END
```

RLCAL Reference Level Calibration

Syntax

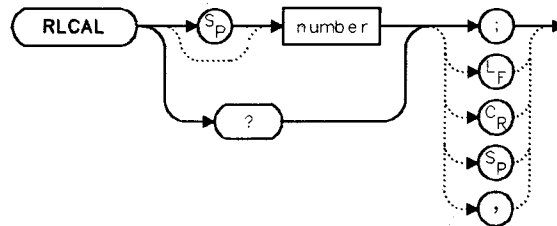

Description

The RLCAL command allows you to calibrate the reference level remotely or check the current calibration. To calibrate the reference level, connect the 300 MHz calibration signal to the RF input. Set the center frequency to 300 MHz, the frequency span to 20 MHz, and the reference level to -10 dBm. Use the RLCAL command to move the input signal to the reference level. When the signal peak falls directly on the reference-level line, the reference level is calibrated. Storing this value in the analyzer in EEROM can be done only from the front panel. The RLCAL command, when queried, returns the current value.

Parameter

number integer from -33 to 33 .

Example

```

10  INTEGER Rlcal
20  INPUT "CONNECT CAL SIGNAL TO RF INPUT AND PRESS CONTINUE",A$
30  OUTPUT 718;"IP;TS;CF 300MHZ;SP 100KHZ;RL ODBM;TS;"
40  OUTPUT 718;"MKPK HI;MKA?;"
50  ENTER 718;Mkamptd
60  OUTPUT 718;"RLCAL?;"
70  ENTER 718;Rlcal
80  Rlcal=Rlcal-INT((Mkamptd+10)/.17)
90  OUTPUT 718;"RLCAL ";Rlcal;";"
100 END

```

ROFFSET

Amplitude Reference Offset

Syntax

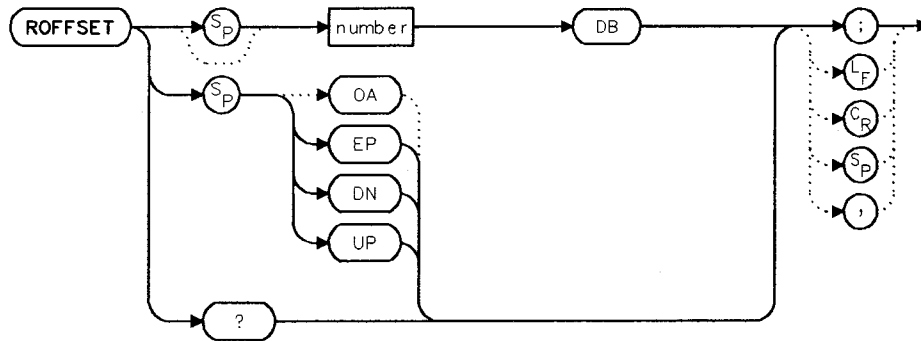

Description

The ROFFSET command introduces an offset to all amplitude readouts (for example, the reference level and marker amplitude). The offset is in dB, regardless of the selected scale and units. The offset can be useful to account for gains or losses in accessories connected to the input of the analyzer. When this function is active, an R appears on the left edge of the display.

Parameters

number real from -100 to 100.
 UP/DN increments of one vertical division.

Preset State

0

Query Response



Example

```

10  INPUT "ENTER REFERENCE LEVEL OFFSET",Roffset
20  OUTPUT 718;"ROFFSET ";Roffset;"DB;"
30  OUTPUT 718;"ROFFSET?;"
40  ENTER 718;Roffset
50  PRINT "AMPLITUDE OFFSET IS ",Roffset
60  END

```

RQS Request Service Conditions

Syntax

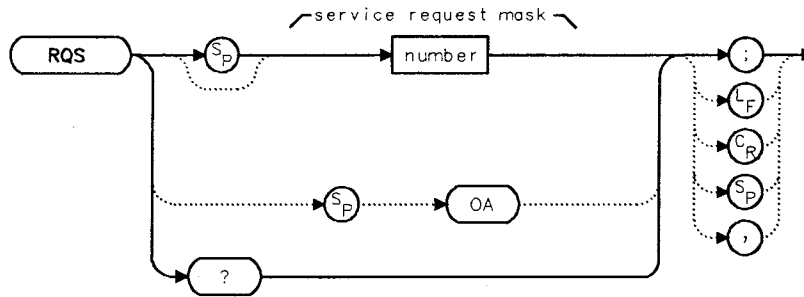

Description

The RQS command sets a bit mask that specifies which service requests can interrupt a program sequence. Each service request has a corresponding bit number and decimal equivalent of that bit number, as shown in Table 5-7. Use the decimal equivalents to set the bit mask. For example, to set a mask for bits 4 and 5, add the decimal equivalents ($16 + 32 = 48$), then send the command RQS 48. For more service request information, refer to Chapter 4.

Table 5-7. Status Register

BIT NUMBER	DECIMAL EQUIVALENT	ANALYZER STATE	DESCRIPTION
7	128		Not used
6	64	RQS	Request service
5	32	ERROR PRESENT	Set when error present
4	16	COMMAND COMPLETE	Any command is completed
3	8		Not used
2	4	END OF SWEEP	Set when any sweep is completed
1	2	MESSAGE	Set when display message appears
0	1	TRIGGER	Trigger is activated

RQS Request Service Conditions

Query Response



Example

```
10  OUTPUT 718;"IP;SNGLS;CF 300MHZ;SP 20MHZ;TS;"
20  OUTPUT 718;"RQS 16;"
30  ON INTR 7 GOTO Srq
40  ENABLE INTR 7;2
50  OUTPUT 718;"SRQ 16;"
60  Idle:  GOTO Idle
70  Srq:   Sbyte=SPOLL(718)
80  PRINT Sbyte
90  PRINT "INTERRUPT GENERATED"
100 OUTPUT 718;"RQS 0;"
110 LOCAL 718
120 END
```

SAVES Save State

Syntax

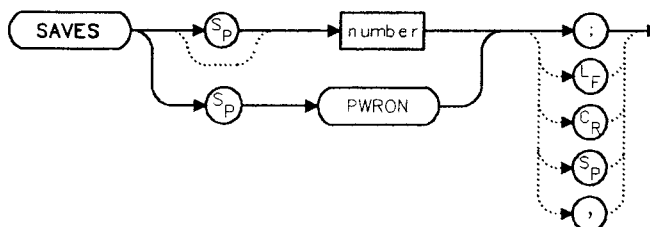

Description

The SAVES command saves the currently displayed instrument state in the specified state register.

Parameters

- number integer from 0 to 9. Numbers less than zero default to zero; numbers greater than nine default to nine.
- PWRON sets the spectrum analyzer to the current state when **LINE** is switched on.

Example

```

10     OUTPUT 718;"IP;CF 300MHZ;SP 20MHZ;"
20     OUTPUT 718;"SAVES PWRON;"
30     END

```

SAVET

Save Trace

Syntax

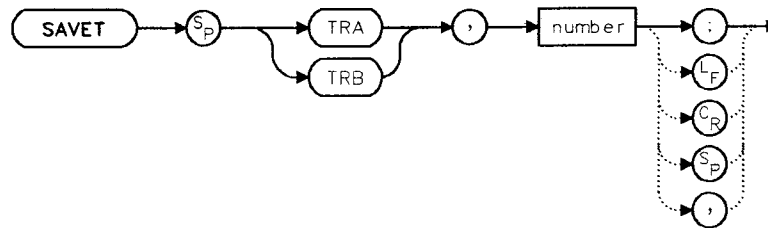

Description

The SAVET command saves the selected trace in the specified trace register. There is only a total of eight save-trace registers in which to store trace data from traces A and B. Be careful not to overwrite previously saved trace data.

Parameters

- TRA stores the contents of trace A.
TRB stores the contents of trace B.
number integer from 0 to 7. Numbers less than zero default to zero; numbers greater than seven default to 7.

Example

```
10 INPUT "SELECT THE TRACE YOU WISH TO SAVE (TRA OR
TRB)",Save_trace$
20 INPUT "SELECT THE REGISTER NUMBER",Reg_number
30 OUTPUT 718;"SAVET ";Save_trace$;" ";Reg_number;"
40 END
```

SER Serial Number

Syntax

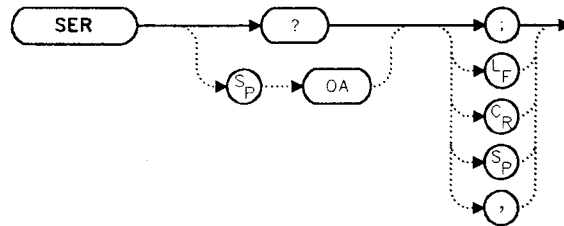

Description

The SER command returns the spectrum analyzer serial number to the computer.

Query Response

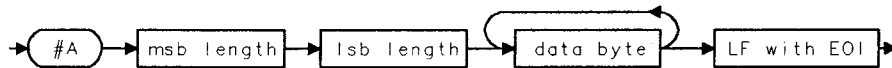

Parameter

msb/lsb represents length of serial # to be returned.

Example

```

10   DIM Ser$[10]
20   OUTUT 718;"SER?;"
30   ENTER 718;Ser$
40   PRINT Ser$
50   END

```

SIGID

Signal Identification

Syntax

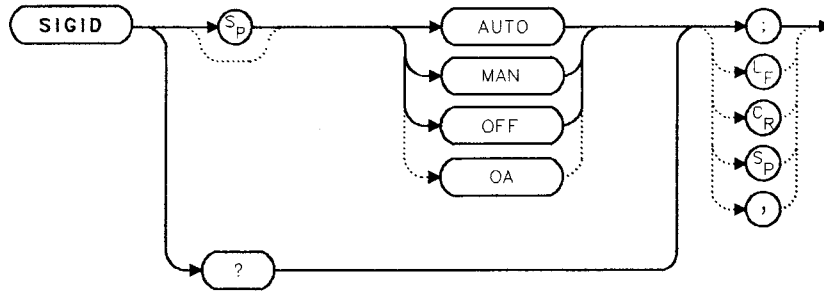

Description

The SIGID command identifies signals for the external mixing frequency bands.

Two signal identification methods are available. AUTO employs the image response method for locating correct mixer responses. Place a marker on the desired signal, then activate SIGID AUTO. The frequency of a correct response appears in the active function block. Use this mode before executing the IDCF command.

The second method of signal identification, MAN, shifts responses both horizontally and vertically. A correct response is shifted horizontally by less than 80 kHz.

To ensure accuracy in MAN mode, limit the frequency span to less than 20 MHz. This command is not available with an HP 8560A Option 002.

Query Response

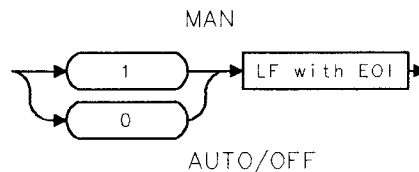

where 1 = manual mode is active and 0 = auto mode is active or SIGID is off.

Example

```

10  OUTPUT 718;"SIGID AUTO;"
20  OUTPUT 718;"IDCF;"
30  OUTPUT 718;"CF?;"
40  ENTER 718;Cf
50  PRINT Cf
60  END
  
```

SNGLS Single Sweep

Syntax

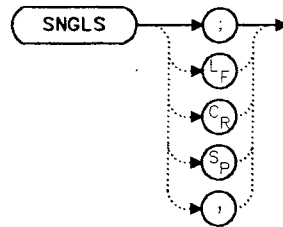

Description

The SNGLS command selects the single-sweep mode. This mode allows only one sweep when trigger conditions are met. When this function is active, an S appears on the left edge of the display.

Example

```
10  OUTPUT 718;"IP;SNGLS;"
20  END
```

SP Frequency Span

Syntax

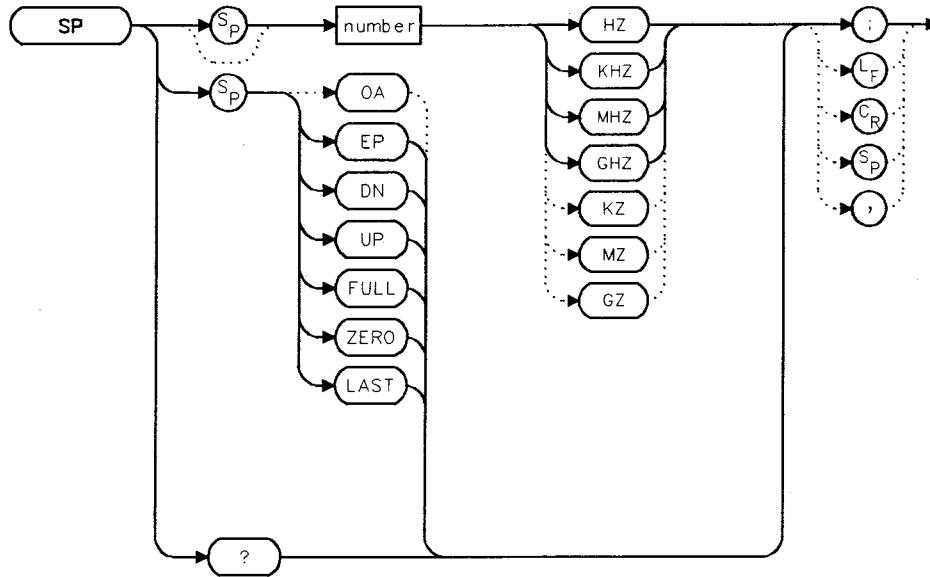

Description

The SP command sets the frequency span. The center frequency does not change with changes in the frequency span; start and stop frequencies do change. Setting the frequency span to 0 Hz effectively allows an amplitude-versus-time mode in which to view signals. This is especially useful for viewing modulation. Querying SP will leave the analyzer in center frequency/span mode.

Parameters

- number real from 0 to 2.9E+9 (HP 8560A);
 0 to 2.9E+9 in low band, 2.75E+9 to 6.5E+9 in high band (HP 8561B);
 0 to 19.25E+9 (HP 8563A);
 0 to 23.75E+9 (HP 8563A Option 026);
 0 to 307E+9 in external mixer mode.
- UP/DN increments in a 1, 2, 5 sequence.

Preset State

- Full span, 2.9 GHz (HP 8560A)
- Full span, 6.5 GHz (HP 8561B)
- Full span, 19.25 GHz (HP 8563A)
- Full span, 23.75 GHz (HP 8563A Option 026)

Query Response



Example

```
10  OUTPUT 718;"IP;CF 300MHZ;SP 20MHZ;"
20  OUTPUT 718;"SP UP;SP?;"
30  ENTER 718;Span
40  PRINT Span
50  END
```

SQUELCH

Squelch

Syntax

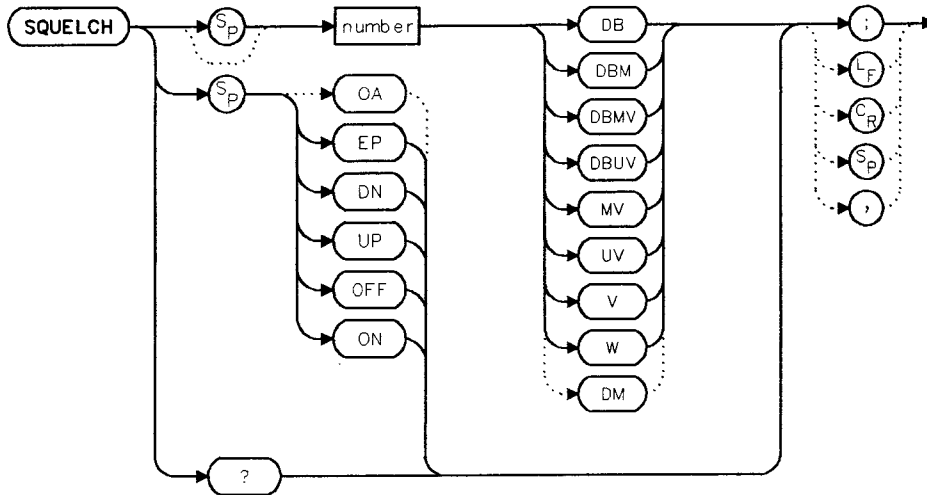

Description

The SQUELCH command adjusts the squelch level for demodulation. When this function is on, a dashed line indicating the squelch level appears on the display. A marker must be active and above the squelch line for demodulation to occur. Refer to the DEMOD command. The default value is -120 dBm.

Parameters

number real from -220 to 30 .
 UP/DN increments by 1 vertical division.

Preset State

Off

Query Response



Example

```
10  OUTPUT 718;"IP;"
20  OUTPUT 718;"FA 88MHZ;FB 108MHZ;"
30  OUTPUT 718;"MKN EP;"
40  PRINT "MOVE MARKER TO SIGNAL TO BE DEMODULATED"
50  PRINT "PRESS HOLD; THEN PRESS CONTINUE"
60  PAUSE
70  INPUT "ENTER DEMODULATION TIME (.1 SEC - 60 SEC)",Dtime
80  OUTPUT 718;"DEMOTD ";Dtime;"SEC;"
90  OUTPUT 718;"SQUELCH EP;"
100 INPUT "ADJUST SQUELCH AS NECESSARY; PRESS HOLD, THEN
ENTER",A$
110 OUTPUT 718;"DEMOT FM;"
120 LOCAL 718
130 END
```

SRCALC

Source Leveling Control

Syntax

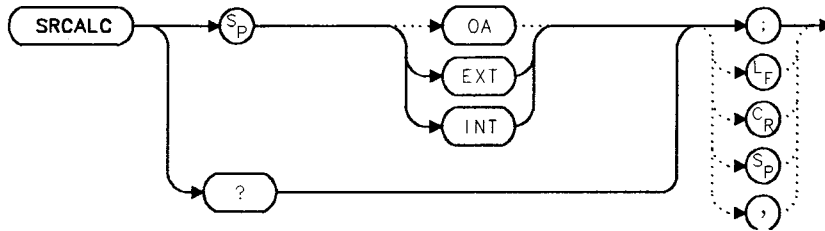

Description

The SRCALC command selects internal (INT) or external (EXT) leveling for use with the built-in tracking generator. This function is only available with an HP 8560A Option 002.

Query Response

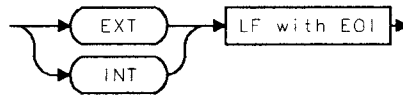

Example

```
10  OUTPUT 718;"IP;SNGLS;TS;CF 300 MHZ;SP 1MHZ;"
20  OUTPUT 718;"SRCPWR ON;SRCPWR -5DBM;TS;"
30  PRINT "CONNECT EXTERNAL LEVELING LOOP.
      PRESS CONTINUE WHEN READY."
40  PAUSE
50  OUTPUT 718;"SRCALC EXT;TS;"
60  WAIT 1
70  OUTPUT 718;"ERR?;"
80  ENTER 718;Err
90  IF Err=900 THEN
100 PRINT "UNLEVELED CONDITION.  CHECK LEVELING LOOP."
110 END IF
120 LOCAL 718
130 END
```

SRCCRSTK Coarse Tracking Adjust

Syntax

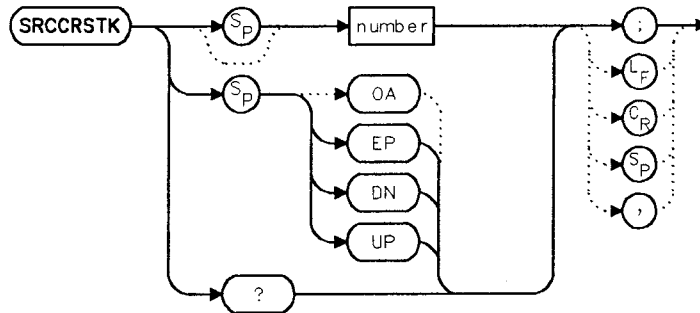

Description

The SRCCRSTK command controls the coarse adjustment to the frequency of the built-in tracking-generator oscillator. Once enabled, this adjustment is made in digital-to-analog-converter (DAC) values from 0 to 255. For fine adjustment, refer to the SRCFINTK command description.

SRCCRSTK is only available with an HP 8560A Option 002.

Parameters

number integer from 0 to 255.
UP/DN increments by 1.

Preset State

32

Query Response



SRCCRSTK Coarse Tracking Adjust

Example

```
10  OUTPUT 718;"IP;"
20  OUTPUT 718;"FA 300KHZ;FB 1GHZ;"
30  OUTPUT 718;"SRCPWR ON;"
40  OUTPUT 718;"SWPCPL SR;RB 10KHZ;"
50  OUTPUT 718;"TS;DONE?;"
60  ENTER 718;Done
70  OUTPUT 718;"SRCCRSTK EP;"
80  PRINT "ADJUST TRACKING (coarse adjust) USING KNOB ON
ANALYZER."
90  PRINT "PRESS [HOLD], THEN CONTINUE WHEN READY."
100 PAUSE
110 OUTPUT 718;"TS;DONE?;"
120 ENTER 718;Done
130 OUTPUT 718;"SRCFINTK EP;"
140 PRINT "ADJUST TRACKING (fine adjust) USING KNOB ON
ANALYZER."
150 PRINT "PRESS [HOLD], THEN CONTINUE WHEN READY."
160 PAUSE
170 OUTPUT 718;"TS;DONE?;"
180 ENTER 718;Done
190 PRINT "CONNECT THRU.  PRESS CONTINUE WHEN READ TO STORE."
200 PAUSE
210 OUTPUT 718;"STORETHRU;"
220 OUTPUT 718;"TS;DONE?;"
230 ENTER 718;Done
240 OUTPUT 718;"NORMLIZE ON;"
250 OUTPUT 718;"TS;DONE?;"
260 ENTER 718;Done
270 OUTPUT 718;"NRPOS 8;TS;"
280 PRINT "RECONNECT DUT.  PRESS CONTINUE WHEN READY."
290 PAUSE
300 LOCAL 718
310 END
```

SRCFINTK Fine Tracking Adjust

Syntax

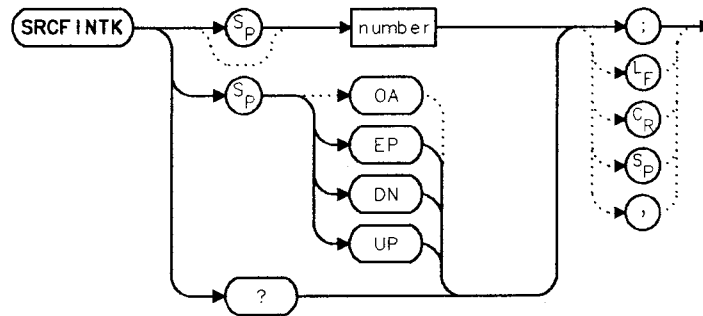

Description

The SRCFINTK command controls the fine adjustment of the frequency of the built-in tracking-generator oscillator. Once enabled, this adjustment is made in digital-to-analog-converter (DAC) values from 0 to 255. For coarse adjustment, refer to the SRCCRSTK command description.

SRCFINTK is only available with an HP 8560A Option 002.

Parameters

number integer from 0 to 255.
UP/DN increments by 1.

Preset State

128

Query Response



SRCFINTK Fine Tracking Adjust

Example

```
10     OUTPUT 718;"IP;"
20     OUTPUT 718;"FA 300KHZ;FB 1GHZ;"
30     OUTPUT 718;"SRCPWR ON;"
40     OUTPUT 718;"SWPCPL SR;RB 10KHZ;"
50     OUTPUT 718;"TS;DONE?;"
60     ENTER 718;Done
70     OUTPUT 718;"SRCCRSTK EP;"
80     PRINT "ADJUST TRACKING (coarse adjust) USING KNOB ON
ANALYZER."
90     PRINT "PRESS [HOLD], THEN CONTINUE WHEN READY."
100    PAUSE
110    OUTPUT 718;"TS;DONE?;"
120    ENTER 718;Done
130    OUTPUT 718;"SRCFINTK EP;"
140    PRINT "ADJUST TRACKING (fine adjust) USING KNOB ON
ANALYZER."
150    PRINT "PRESS [HOLD], THEN CONTINUE WHEN READY."
160    PAUSE
170    OUTPUT 718;"TS;DONE?;"
180    ENTER 718;Done
190    PRINT "CONNECT THRU.  PRESS CONTINUE WHEN READ TO STORE."
200    PAUSE
210    OUTPUT 718;"STORETHRU;"
220    OUTPUT 718;"TS;DONE?;"
230    ENTER 718;Done
240    OUTPUT 718;"NORMLIZE ON;"
250    OUTPUT 718;"TS;DONE?;"
260    ENTER 718;Done
270    OUTPUT 718;"NRPOS 8;TS;"
280    PRINT "RECONNECT DUT.  PRESS CONTINUE WHEN READY."
290    PAUSE
300    LOCAL 718
310    END
```

SRCPOFS

Source Power Offset

Syntax

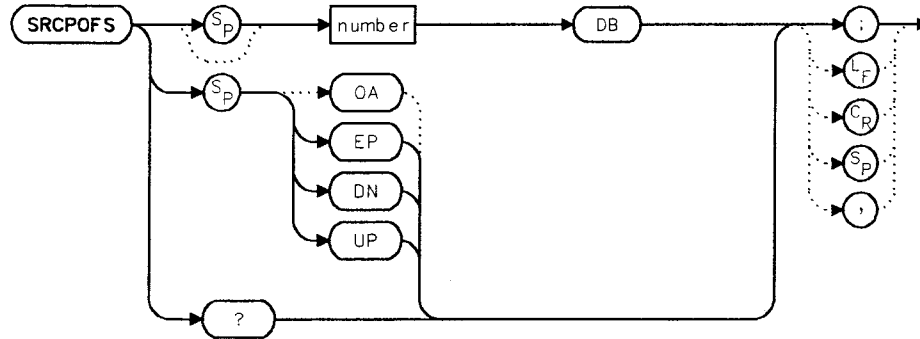

Description

The SRCPOFS command offsets the displayed power of the built-in tracking generator. This function may be used to take into account system losses (for example, cable loss) or gains (for example, preamplifier gain) reflecting the actual power delivered to the device under test.

SRCPOFS is only available with an HP 8560A Option 002.

Parameters

- number real from -100 dB to +100 dB.
- UP/DN increments in steps equal to the value set by SRCPSTP.

Preset State

0.0 dB

Query Response



Example

```

10  OUTPUT 718;"IP;SNGLS;"
20  OUTPUT 718;"CF 300MHZ;SP OHZ;TS;"
30  OUTPUT 718;"SRCPWR ON;SRCPWR -10DBM;"
40  OUTPUT 718;"SRCPSWP ON;SRCPSWP 10DB;TS;"
50  INPUT "ENTER GAIN OF PREAMPLIFIER UNDER TEST",Gain
60  OUTPUT 718;"SRCPOFS ";Gain;"DB;"
70  OUTPUT 718;"TS;MKPK HI;MKD;MKMIN;"
80  END

```

SRCPSTP

Source Power Step

Syntax

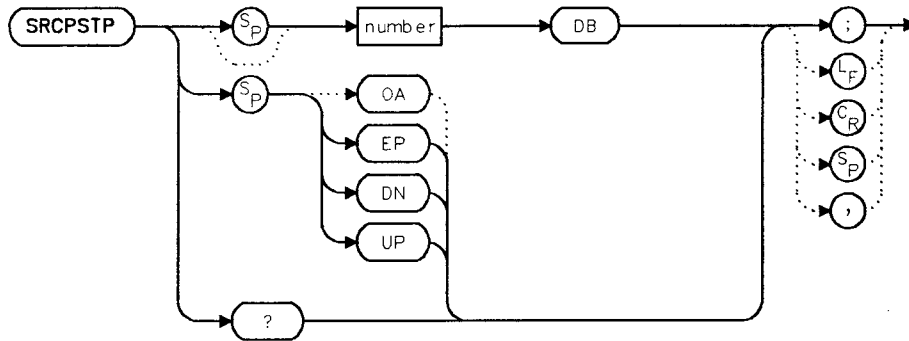

Description

The SRCPSTP command sets the step size of the source power level, source power offset, and power-sweep range functions. This function is only available with an HP 8560A Option 002.

Parameters

number real from 0.1 dB to 12.75 dB; 0.05 dB resolution via HP-IB.
 UP/DN 0.1 dB steps.

Preset State

1.0 dB

Query Response



Example

```

10  OUTPUT 718;"IP;SNGLS;"
20  OUTPUT 718;"CF 300MHZ;SP OHZ;TS;"
30  OUTPUT 718;"SRCPWR ON;SRCPWR -10DBM;"
40  OUTPUT 718;"SRCPSTP 1.0DB;"
50  OUTPUT 718;"SRCPWR UP;"
60  OUTPUT 718;"SRCPWR?;"
70  ENTER 718;Pwr
80  END

```

SRCPSWP Source Power Sweep

Syntax

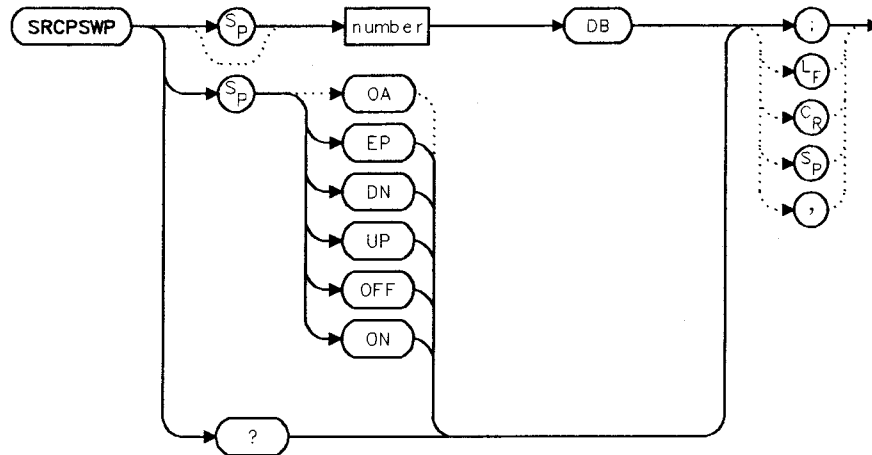

Description

The SRCPSWP command activates and deactivates the power-sweep function, where the output power of the tracking generator is swept over the power-sweep range chosen. The starting source power level is set using the SRCPWR command. The output power of the tracking generator is swept according to the sweep rate of the spectrum analyzer.

SRCPSWP is only available with an HP 8560A Option 002.

Parameters

- number real from 0 dB to 12.75 dB; 0.05 dB resolution via HP-IB.
- UP/DN increments in steps equal to the value set by SRCPSTP.

Preset State

10 dB

Query Response



SRCPSWP Source Power Sweep

Example

```
10    OUTPUT 718;"IP;SNGLS;"
20    OUTPUT 718;"CF 300MHZ;SP OHZ;TS;"
30    OUTPUT 718;"SRCPWR ON;SRCPWR -10DBM;"
40    OUTPUT 718;"SRCPSWP ON;SRCPSWP 10DB;TS;"
50    OUTPUT 718;"MKPK HI;MKD;MKMIN;TS;"
60    END
```

SRCPWR Source Power

Syntax

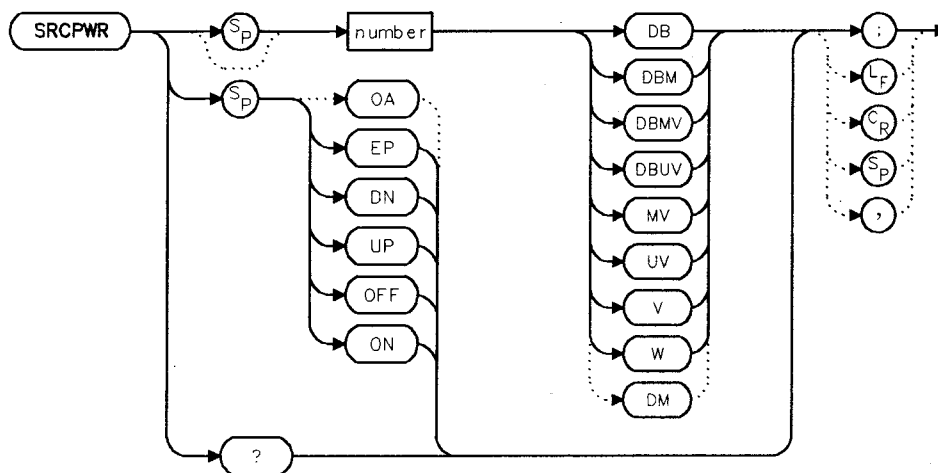

Description

The SRCPWR command turns the built-in tracking generator on and off and adjusts the output power. This function is only available with an HP 8560A Option 002.

Parameters

number real from -10 dBm to $+2.8$ dBm; 0.05 dB resolution via HP-IB.
 UP/DN increments in steps equal to the value set by SRCPSTP.

Preset State

-10 dBm

Query Response



SRCPWR Source Power

Example

```
10  OUTPUT 718;"IP;SNGLS;"
20  OUTPUT 718;"FA 300KHZ;FB 1GHZ;"
30  OUTPUT 718;"SRCPWR ON;"
40  OUTPUT 718;"SWPCPL SR;"
50  PRINT "CONNECT THRU.  PRESS CONTINUE WHEN READY TO STORE."
60  PAUSE
70  OUTPUT 718;"SRCTKPK;DONE?;"
80  ENTER 718;Done
90  OUTPUT 718;"TS;DONE?;"
100 ENTER 718;Done
110 OUTPUT 718;"STORETHRU;"
120 OUTPUT 718;"TS;DONE?;"
130 ENTER 718;Done
140 OUTPUT 718;"NORMLIZE ON;"
150 OUTPUT 718;"TS;DONE?;"
160 ENTER 718;Done
170 OUTPUT 718;"NRPOS 5;TS;"
180 PRINT "RECONNECT DUT.  PRESS CONTINUE WHEN READY."
190 PAUSE
200 OUTPUT 718;"NRL -10DB;"
210 OUTPUT 718;"TS;DONE?;"
220 ENTER 718;Done
230 LOCAL 718
240 END
```

SRCTKPK Source Tracking Peak

Syntax

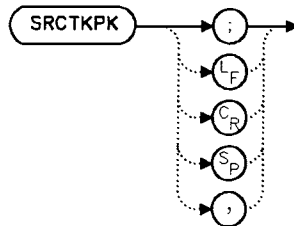

Description

The SRCTKPK command activates a routine which automatically adjusts both the coarse- and fine-tracking adjustments to obtain the peak response of the tracking generator on the spectrum-analyzer display. Tracking peak is not necessary for resolution bandwidths greater than or equal to 300 kHz. A thru connection should be made prior to peaking in order to ensure accuracy.

SRCTKPK is only available with an HP 8560A Option 002.

Example

```

10  OUTPUT 718;"IP;SNGLS;"
20  OUTPUT 718;"FA 300KHZ;FB 1GHZ;"
30  OUTPUT 718;"SRCPWR ON;"
40  OUTPUT 718;"SWPCPL SR;"
50  OUTPUT 718;"RB 100KHZ;"
50  OUTPUT 718;"SRCTKPK;DONE?;"
60  ENTER 718;Done
70  LOCAL 718
80  END

```

SRQ

Service Request

Syntax

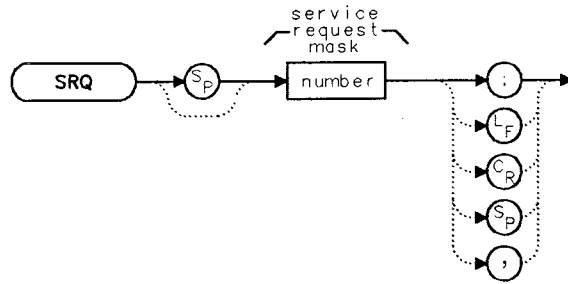

Description

The SRQ command triggers a service request. This command allows you to force a service request and test a program designed to handle service requests. However, the service request can be triggered only if it is first masked using the RQS command. For more service request information, refer to Chapter 4.

Example

```
10  OUTPUT 718;"IP;SNGLS;CF 300MHZ;TS;"
20  OUTPUT 718;"RQS 16;"
30  ON INTR 7 GOTO Srq
40  ENABLE INTR 7;2
50  OUTPUT 718;"SRQ 16;"
60  Idle:  GOTO Idle
70  Srq:   Sbyte=SPOLL(718)
80         PRINT Sbyte
90         PRINT "INTERRUPT GENERATED"
100 OUTPUT 718;"RQS 0;"
110 LOCAL 718
120 END
```

SS Center Frequency Step-Size

Syntax

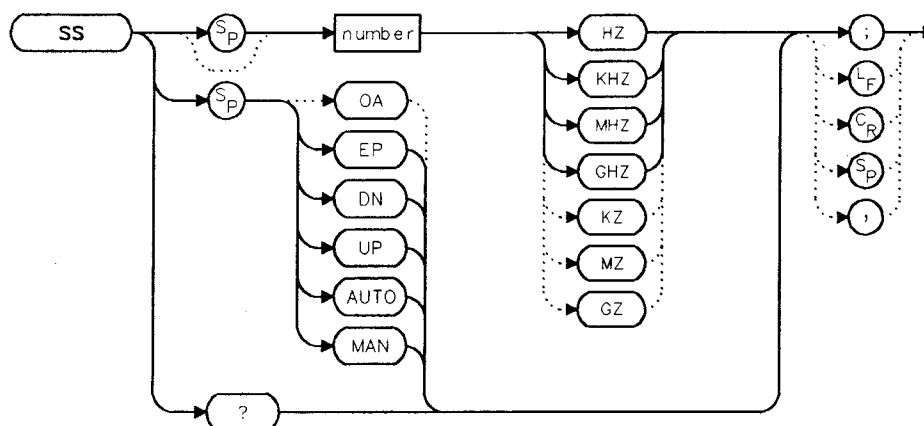

Description

The SS command sets the center frequency step-size. This is normally a coupled function. After entering a step size, execute the CF command using the UP or DN parameter. The center frequency is adjusted by the selected step size. This function is useful for quickly tuning to the harmonics of an input signal. The default value is 10% of span. When the span is 0 Hz, the default value is one-fourth of the resolution bandwidth.

Parameters

number real from 25 to 26.93E+9 (hardware dependent).
UP/DN increments in a 1, 2, 5, 10 sequence.

Preset State

290 MHz, AUTO (HP 8560A)
650 MHz, AUTO (HP 8561B)
1.925 GHz, AUTO (HP 8563A)
2.375 GHz, AUTO (HP 8563A Option 026)

SS Center Frequency Step-Size

Query Response



Example

```
10 CLEAR 718
20 OUTPUT 718;"IP;SNGLS;CF300MHZ;SP 20MZ;TS;"
30 OUTPUT 718;"MKPK HI;MKRL;TS;MKF?;MKA?;"
40 ENTER 718 USING "K";Mk_freq,Mk_amp
50 OUTPUT 718;"SS ";Mk_freq;"HZ"
60 OUTPUT 718;"CF UP;TS;MKPK HI;MKA?;"
70 ENTER 718;Mk_ampl
80 PRINT "The fundamental is ";Mk_amp-MK_ampl;" db above the
first harmonic."
90 END
```

ST Sweep Time

Syntax

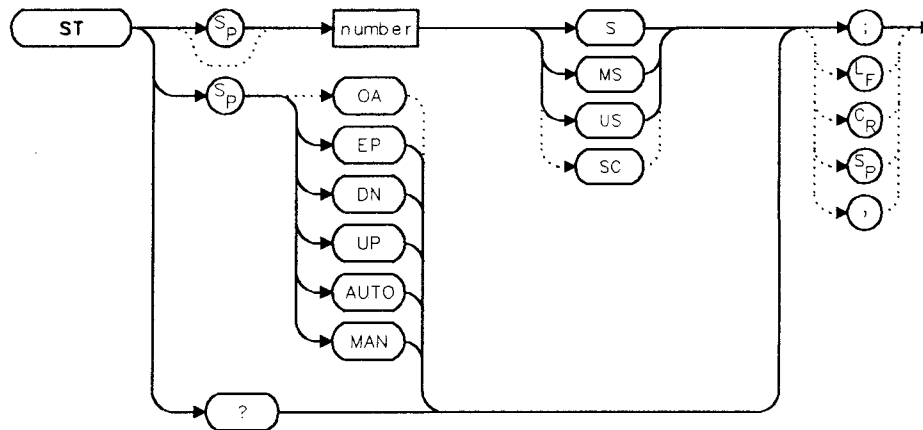

Description

The ST command sets the sweep time. This is normally a coupled function which is automatically set to the optimum value allowed by the current instrument settings. Alternatively, you may specify the sweep time. Note that when the specified sweep time is too fast for the current instrument settings, the instrument is no longer calibrated and the message **MEAS UNCAL** appears on the display. When using an HP 8560A or HP 8561B, the sweep time cannot be adjusted when the resolution bandwidth is set to 10 Hz, 30 Hz, or 100 Hz. However, the sweep time can be adjusted in 10 Hz, 30 Hz, or 100 Hz resolution bandwidths when using an HP 8563A.

Parameters

- number real from 50E-3 to 100 when the span is greater than 0 Hz; 50E-6 to 60 when the span equals 0 Hz. When the resolution bandwidth is ≤ 100 Hz, the sweep time cannot be adjusted.
- UP/DN increments in a 1, 2, 5, 10 sequence.

Preset State

- 60 ms, AUTO (HP 8560A)
- 200 ms, AUTO (HP 8561B)
- 400 ms, AUTO (HP 8563A)
- 500 ms, AUTO (HP 8563A Option 026)

ST Sweep Time

Query Response



Example

```
10  OUTPUT 718;"ST 500MS;"
20  OUTPUT 718;"ST DN;"
30  OUTPUT 718;"ST?;"
40  ENTER 718;St
50  PRINT St
60  END
```

STB Status Byte Query

Syntax

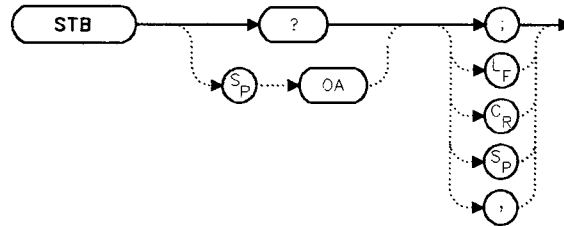

Description

The STB command returns to the controller the decimal equivalent of the bits set in the status byte (see the RQS and SRQ commands). STB is equivalent to a serial poll command. The RQS and associated bits are cleared in the same way that a serial poll command would clear them. For more information, refer to Chapter 4.

Query Response



Example

```

10  OUTPUT 718;"IP;SNGLS;CF 300MHZ;SP 20MHZ;TS;"
20  OUTPUT 718;"VAVG 10;RQS 16;"
30  ON INTR 7 GOTO Srq
40  ENABLE INTR 7;2
50  OUTPUT 718;"TS;"
60  Idle:  GOTO Idle
70  Srq:   OUTPUT 718;"STB?;"
80         ENTER 718;Sbyte
90         PRINT Sbyte
100  PRINT "VIDEO AVERAGING IS COMPLETE"
110  OUTPUT 718;"RQS 0;"
120  LOCAL 718
130  END

```

STOREOPEN

Store Open

Syntax

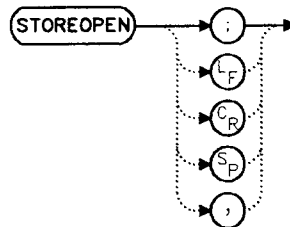

Description

The STOREOPEN command saves the current instrument state and trace A into nonvolatile memory. This command must be used in conjunction with the STORESHORT command and must precede the STORESHORT command. The data obtained during the STOREOPEN procedure is averaged with the data obtained during the STORESHORT procedure to provide an open/short calibration. The instrument state (that is, instrument settings) must *not* change between the STOREOPEN and STORESHORT operations in order for the open/short calibration to be valid. Refer to the STORESHORT command description for more information.

Note

The STOREOPEN command is primarily intended for use with a tracking generator.



Example

```
10  OUTPUT 718;"IP;SNGLS;"
20  OUTPUT 718;"FA 300KHZ;FB 1GHZ;"
30  OUTPUT 718;"SRCPWR ON;"           !HP 8560A Option
002 only.
40  OUTPUT 718;"SWPCPL SR;"
50  PRINT "CONNECT OPEN.  PRESS CONTINUE WHEN READY TO STORE."
60  PAUSE
70  OUTPUT 718;"TS;DONE?;"
80  ENTER 718;Done
90  OUTPUT 718;"STOREOPEN;"
100 PRINT "CONNECT SHORT.  PRESS CONTINUE WHEN READY
      TO STORE AND AVERAGE."
110 PAUSE
120 OUTPUT 718;"TS;DONE?;"
130 ENTER 718;Done
140 OUTPUT 718;"STORESHORT;"
150 OUTPUT 718;"TS;DONE?;"
160 ENTER 718;Done
170 OUTPUT 718;"NORMLIZE ON;"
180 OUTPUT 718;"TS;DONE?;"
190 ENTER 718;Done
200 LOCAL 718
210 END
```

STORESHORT

Store Short

Syntax

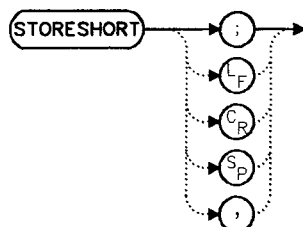

Description

The STORESHORT command takes currently displayed trace A data and averages this data with previously stored open data, and stores it in trace B. This command is used in conjunction with the STOREOPEN command and must be preceded by it for proper operation. Refer to the STOREOPEN command description for more information.

The state of the open/short average trace is stored in state register #8.

Note



The STORESHORT command is primarily intended for use with a tracking generator.

Example

```
10  OUTPUT 718;"IP;SNGLS;"
20  OUTPUT 718;"FA 300KHZ;FB 1GHZ;"
30  OUTPUT 718;"SRCPWR ON;"           !HP 8560A Option
002 only.
40  OUTPUT 718;"SWPCPL SR;"
50  PRINT "CONNECT OPEN.  PRESS CONTINUE WHEN READY TO STORE."
60  PAUSE
70  OUTPUT 718;"TS;DONE?;"
80  ENTER 718;Done
90  OUTPUT 718;"STOREOPEN;"
100 PRINT "CONNECT SHORT.  PRESS CONTINUE WHEN READY
      TO STORE AND AVERAGE."
110 PAUSE
120 OUTPUT 718;"TS;DONE?;"
130 ENTER 718;Done
140 OUTPUT 718;"STORESHORT;"
150 OUTPUT 718;"TS;DONE?;"
160 ENTER 718;Done
170 OUTPUT 718;"NORMLIZE ON;"
180 OUTPUT 718;"TS;DONE?;"
190 ENTER 718;Done
200 LOCAL 718
210 END
```

STORETHRU

Store Thru

Syntax

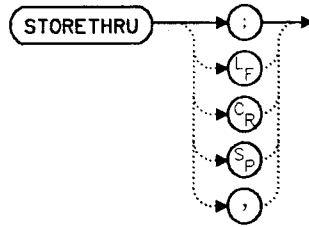

Description

The STORETHRU command stores a thru-calibration trace into trace B and into the nonvolatile memory of the spectrum analyzer.

The state of the thru information is stored in state register #9.

Note

The STORETHRU command is primarily intended for use with a tracking generator.



Example

```
10  OUTPUT 718;"IP;SNGLS;"
20  OUTPUT 718;"FA 300KHZ;FB 1GHZ;"
30  OUTPUT 718;"SRCPWR ON;"                !HP 8560A Option
002 only.
40  OUTPUT 718;"SWPCPL SR;"
50  OUTPUT 718;"RB 300KHZ;TS;"
60  PRINT "CONNECT THRU. PRESS CONTINUE WHEN READY TO STORE."
70  PAUSE
80  OUTPUT 718;"SRCTKPK;DONE?;"
90  ENTER 718;Done
100 OUTPUT 718;"TS;DONE?;"
110 ENTER 718;Done
120 OUTPUT 718;"STORETHRU;"
130 OUTPUT 718;"TS;DONE?;"
140 ENTER 718;Done
150 OUTPUT 718;"NORMLIZE ON;"
160 OUTPUT 718;"TS;DONE?;"
170 ENTER 718;Done
180 LOCAL 718
190 END
```

SWPCPL Sweep Couple

Syntax

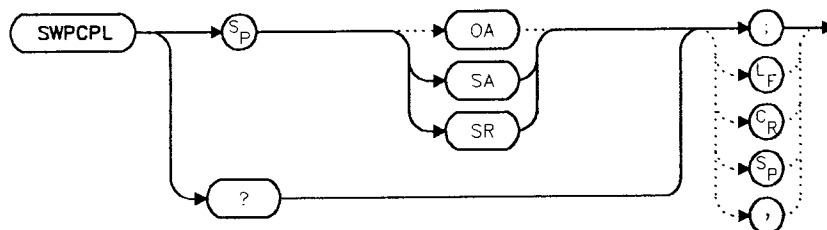

Description

The SWPCPL command selects either a stimulus-response (SR) or spectrum-analyzer (SA) auto-coupled sweep time. In stimulus-response mode, auto-coupled sweep times are usually much faster for swept-response measurements. Stimulus-response auto-coupled sweep times are typically valid in stimulus-response measurements when the system's frequency span is less than 20 times the bandwidth of the device under test.

Preset State

SA (spectrum analyzer mode)

Query Response

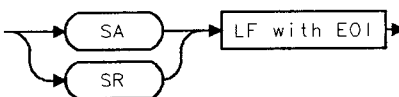

Example

```

10  OUTPUT 718;"IP;SNGLS;"
20  OUTPUT 718;"FA 300KHZ;FB 1GHZ;"
30  OUTPUT 718;"SRCPWR ON;"           !HP 8560A Option 002
only.
40  OUTPUT 718;"SWPCPL SR;"
50  OUTPUT 718;"SRCTKPK;DONE?;"     !HP 8560A Option 002
only.
60  ENTER 718;Done
70  LOCAL 718
80  END

```

SWPOUT Sweep Output

Syntax

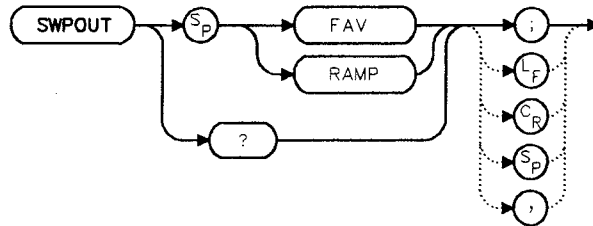

Description

The SWPOUT command selects the sweep-related signal that is available from J8 LO SWP0.5V/GHz| OUTPUT on the rear panel. FAV provides a voltage nominally equal to 0.5V/GHz of the tuned frequency when in internal mixing. RAMP provides a 0—10 V ramp corresponding to the sweep ramp that tunes the first local oscillator (LO). For the HP 8561B and HP 8563A, in multiband sweeps, one sweep ramp is provided for each frequency band.

When configured to use preselected external mixers, the external mixer preselector DAC is summed into the 0.5 V/GHz ramp.

Query Response

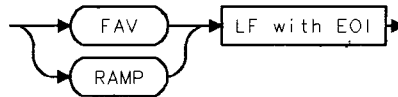

Example

```

10 INPUT "SELECT THE SIGNAL OUTPUT OF J8 (RAMP OR FAV)",Sig_out$
20 OUTPUT 718;"SWPOUT ";Sig_out$;"
30 OUTPUT 718;"SWPOUT?;"
40 ENTER 718;Sig_out$
50 PRINT "SELECTED SIGNAL OUTPUT IS ",Sig_out$
60 END

```

TDF

Trace Data Format

Syntax

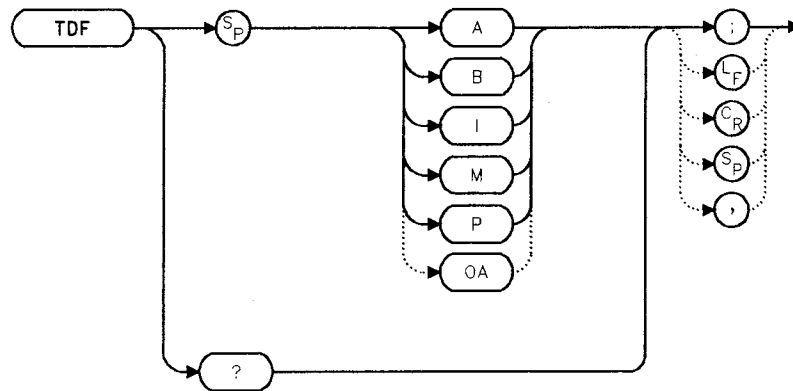

Description

The TDF command selects the format used to input and output trace data (see the TRA/TRB command or refer to Chapter 4). You must specify the desired format when transferring data from the spectrum analyzer to a computer; this is optional when transferring data to the analyzer.

Parameters

- A specifies A-block data format.
- B specifies binary data format.
- I specifies I-block data format.
- M specifies ASCII data format.
- P specifies real number output format. Numbers are in Hz, volts, watts, dBm, dBmV, dB μ V, dBV, or seconds.

Query Response

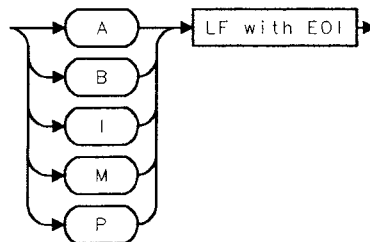

Example

```

10  REAL A(1:601)
20  OUTPUT 718;"IP;CF 300MHZ;SP 20MHZ;SNGLS;TS;"
30  CALL Get_data(Fa,Fb,Rl,Rb,Vb,St,Lg,Aunits$)
40  OUTPUT 718;"TDF P;TRA?;"
50  ENTER 718;A(*)
60  PRINT "PRESS CONTINUE TO RETURN DATA TO THE ANALYZER."
70  PAUSE
80  OUTPUT 718;"IP;TDF P;TS;VIEW TRA;"
90  CALL Enter_data(Fa,Fb,Rl,Rb,Vb,St,Lg,Aunits$)
100 OUTPUT 718;"TRA ";
110   FOR I=1 TO 600
120     OUTPUT 718;A(I);"DBM,"
130   NEXT I
140 OUTPUT 718;A(601);"DBM;"
150 END
160 SUB Enter_data(Fa,Fb,Rl,Rb,Vb,St,Lg,Aunits$)
170 OUTPUT 718;"FA ";Fa;"HZ;"
180 OUTPUT 718;"FB ";Fb;"HZ;"
190 OUTPUT 718;"AUNITS ";Aunits$;";"
200 OUTPUT 718;"RB ";Rb;"HZ;"
210 OUTPUT 718;"VB ";Vb;"HZ;"
220 OUTPUT 718;"ST ";St;"SEC;"
230 IF Lg=0 THEN
240   OUTPUT 718;"LN;"
250 ELSE
260   OUTPUT 718;"LG ";Lg;"DB;"
270 END IF
280 SUBEND
290 SUB Get_data(Fa,Fb,Rl,Rb,Vb,St,Lg,Aunits$)
300 OUTPUT 718;"FA?;FB?;RL?;RB?;VB?;ST?;LG?;AUNITS?;"
310 ENTER 718 USING "K";Fa,Fb,Rl,Rb,Vb,St,Lg,Aunits$
320 PRINT Fa,Fb,Rl,Rb,Vb,St,Lg,Aunits$
330 SUBEND

```

TH Threshold

Syntax

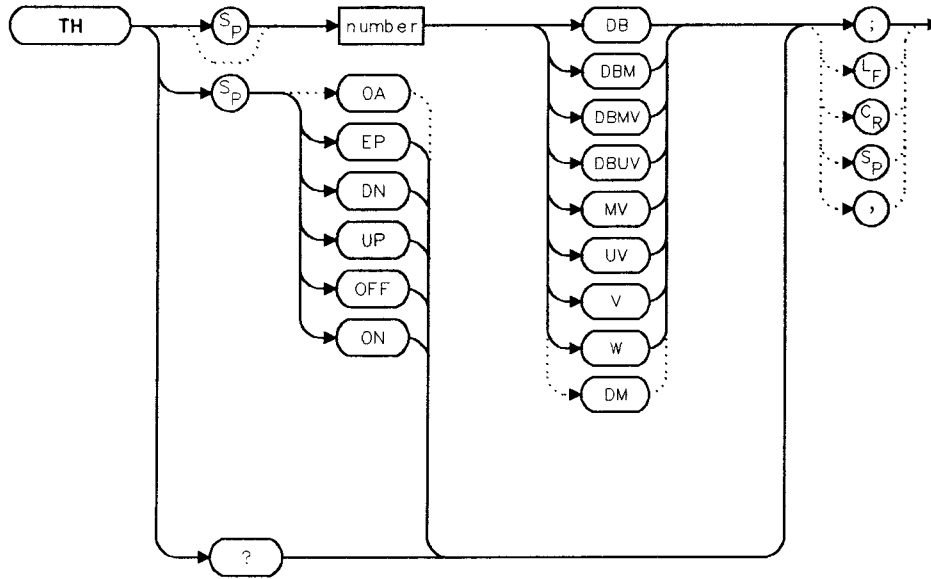

Description

The TH command sets the minimum amplitude level and clips data at this value. Default value is -90 dBm. See also MKPT. MKPT does not clip data below its threshold.

Note

When a trace is in max-hold mode, if the threshold is raised above any of the trace data, the data below the threshold will be permanently lost.



Parameters

number dependent upon the chosen amplitude units.
UP/DN increments by one vertical division.

Preset State

Off

Query Response**Example**

```
10  OUTPUT 718;"TH EP;"  
20  PRINT "SELECT THE THRESHOLD ON THE ANALYZER"  
30  PRINT "PRESS HOLD THEN PRESS CONTINUE"  
40  PAUSE  
50  END
```

TITLE

Title Entry

Syntax

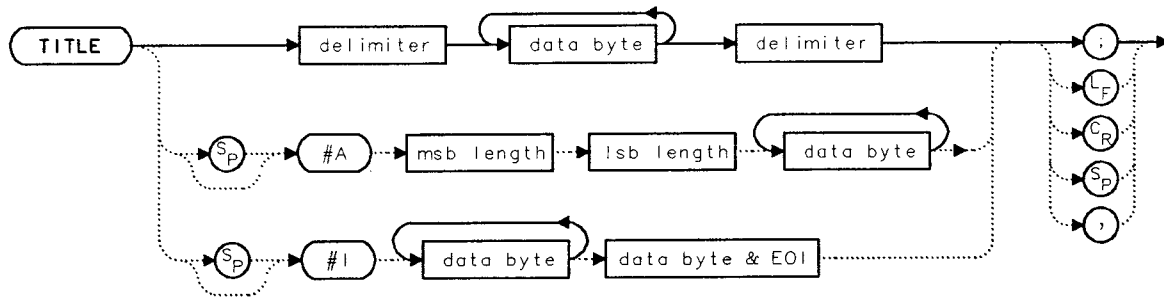

Description

The TITLE command places character data in the title area of the display, which is in the upper-right corner. A title can be up to two rows of sixteen characters each and can include the special characters shown in Table 5-8. Carriage return and line feed characters are not recommended. For more information on creating titles, refer to Chapter 4 of this manual.

Table 5-8. Special Printing Characters

Code	Character
60	<
62	>
168	←
169	→
225	α
226	β
237	μ
240	π
241	θ
242	ρ
243	σ
244	τ
247	ω
249	Δ

Parameter

msb/l**s**b represents the length of the title as two 8-bit bytes.

Example

```
10  OUTPUT 718;"TITLE@This is a title@"  
20  END
```

TM

Trigger Mode

Syntax

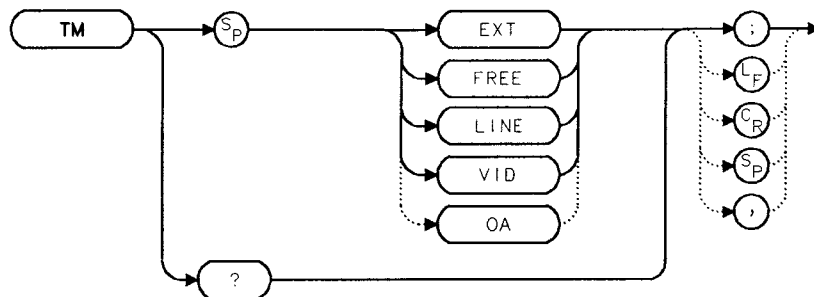

Description

The TM command selects a trigger mode. Selected trigger conditions must be met in order for a sweep to occur. The available trigger modes are listed below. When any trigger mode other than free run is selected, a T appears on the left edge of the display.

Parameters

- EXT selects the external mode. Connect an external trigger source to J5 EXT TRIG INPUT on the rear panel of the spectrum analyzer. The source must range from 0 to 5 V (TTL). The trigger occurs on the rising, positive edge of the signal (about 1.5 V).
- FREE selects the free-run mode. Sweep triggers occur as fast as the spectrum analyzer will allow.
- LINE selects the line mode. Sweep triggers occur at intervals synchronized to the line frequency.
- VID selects the video mode. Sweep triggers occur whenever the positively-sloped part of the input signal passes through the video trigger level. This trigger level can be changed (refer to the VTL command), and a dashed line appears on the screen to denote (approximately) the selected level.

Preset State

Free-run mode

Query Response

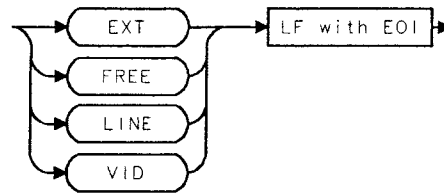

Example

```
10  OUTPUT 718;"TM VID;"  
20  OUTPUT 718;"VTL -20DBM;"  
30  END
```

TRA/TRB

Trace Data Input/Output

Syntax

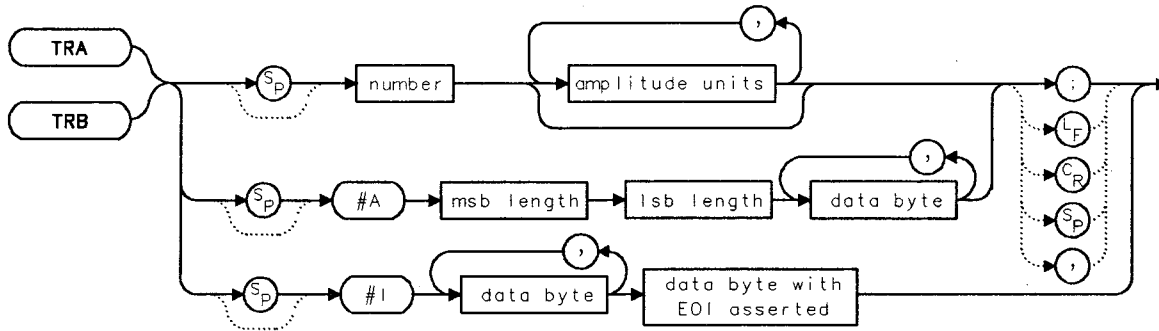

Description

The TRA and TRB commands provide a method for transferring trace data to or from a computer. The available data formats are real number (P) format, binary (B) format, A-block format, I-block format, or measurement units (M) format. Transfers to the computer must be completed within 30 seconds or the transfer will be aborted. For instructions on transferring data and more examples, refer to Chapter 4.

Parameter

msb/lsb represents the length of the trace as two 8-bit bytes.

Query Response

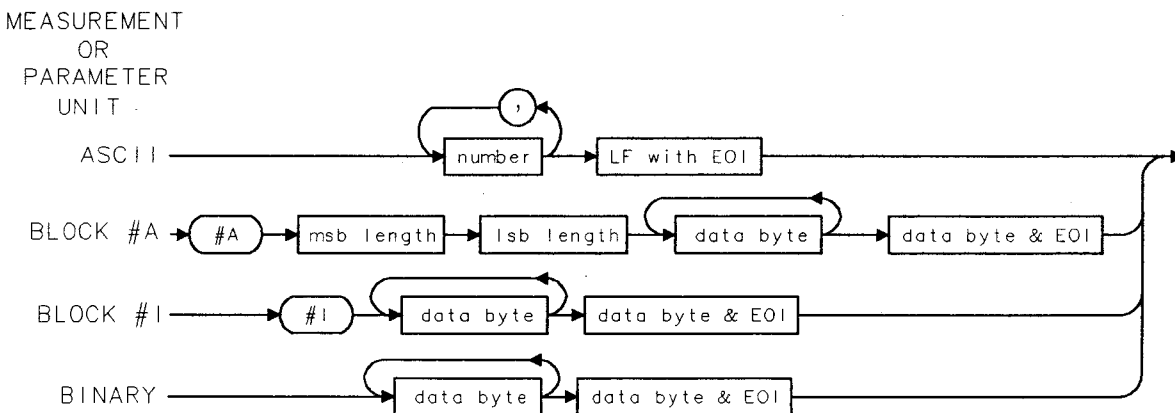

Example

```

10 REAL A(1:601)
20 OUTPUT 718;"IP;CF 300MHZ;SP 20MHZ;SNGLS;TS;"
30 CALL Get_data(Fa,Fb,Rl,Rb,Vb,St,Lg,Aunits$)
40 OUTPUT 718;"TDF P;TRA?;"
50 ENTER 718;A(*)
60 PRINT "PRESS CONTINUE TO RETURN DATA TO THE ANALYZER."
70 PAUSE
80 OUTPUT 718;"IP;TDF P;TS;VIEW TRA;"
90 CALL Enter_data(Fa,Fb,Rl,Rb,Vb,St,Lg,Aunits$)
100 OUTPUT 718;"TRA ";
110   FOR I=1 TO 600
120     OUTPUT 718;A(I);"DBM,"
130   NEXT I
140 OUTPUT 718;A(601);"DBM;"
150 END
160 SUB Enter_data(Fa,Fb,Rl,Rb,Vb,St,Lg,Aunits$)
170 OUTPUT 718;"FA ";Fa;"HZ;"
180 OUTPUT 718;"FB ";Fb;"HZ;"
190 OUTPUT 718;"AUNITS ";Aunits$;";"
200 OUTPUT 718;"RB ";Rb;"HZ;"
210 OUTPUT 718;"VB ";Vb;"HZ;"
220 OUTPUT 718;"ST ";St;"SEC;"
230 IF Lg=0 THEN
240   OUTPUT 718;"LN;"
250 ELSE
260   OUTPUT 718;"LG ";Lg;"DB;"
270 END IF
280 SUBEND
290 SUB Get_data(Fa,Fb,Rl,Rb,Vb,St,Lg,Aunits$)
300 OUTPUT 718;"FA?;FB?;RL?;RB?;VB?;ST?;LG?;AUNITS?;"
310 ENTER 718 USING "K";Fa,Fb,Rl,Rb,Vb,St,Lg,Aunits$
320 PRINT Fa,Fb,Rl,Rb,Vb,St,Lg,Aunits$
330 SUBEND

```

TS

Take Sweep

Syntax

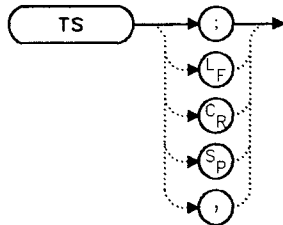

Description

TS commands the spectrum analyzer to take one full sweep across the trace display. Commands following TS are not executed until after the analyzer has finished the trace sweep. This ensures that the instrument is set to a known condition before subsequent commands are executed. For information on how to synchronize a program using TS and the DONE command, refer to Chapter 4.

Example

```
10 OUTPUT 718;"IP;SNGLS;"
20 OUTPUT 718;"TS;DONE?;"
30 ENTER 718;Done
40 PRINT Done
50 END
```

TWNDOW Trace Window

Syntax

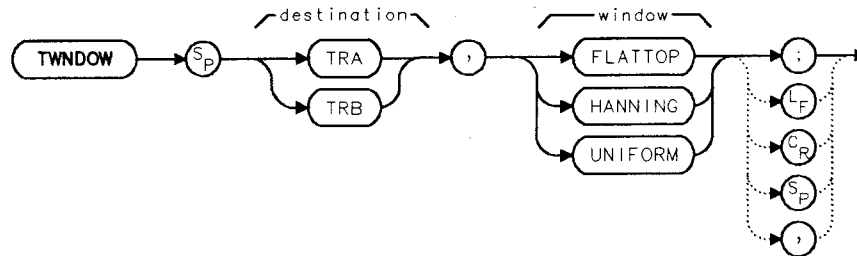

Note



The destination trace is not currently used, but it must be supplied for future compatibility.

Description

The TWNDOW command creates a window trace array for the fast Fourier transform (FFT) function. The trace-window function creates a trace array according to three built-in algorithms: UNIFORM, HANNING, and FLATTOP. When used with the FFT command, the three algorithms give resultant passband shapes that represent a compromise among amplitude uncertainty, sensitivity, and frequency resolution. Refer to the FFT command description for more information.

The three types of windows which are available when using the TWNDOW command are:

- FLATTOP provides optimum amplitude accuracy.
- HANNING provides an amplitude accuracy/frequency resolution compromise, which is useful for general purpose measurements, as well as noise measurements.
- UNIFORM provides equal weighting of the time record for measuring transients.

Preset State

HANNING

TWNDOW Trace Window

Example

```
10  OUTPUT 718;"IP;"
20  OUTPUT 718;"CF 300 MHZ;"
30  OUTPUT 718;"SP OHZ;ST 50MS;"
40  OUTPUT 718;"TWNDOW TRA, UNIFORM;"
50  OUTPUT 718;"CLRW TRB;"
60  OUTPUT 718;"SNGLS;TS;TS;"
70  OUTPUT 718;"FFT TRA,TRB,TRA;"
80  OUTPUT 718;"BLANK TRB;"
90  OUTPUT 718;"VIEW TRA;"
100 END
```

VAVG Video Average

Syntax

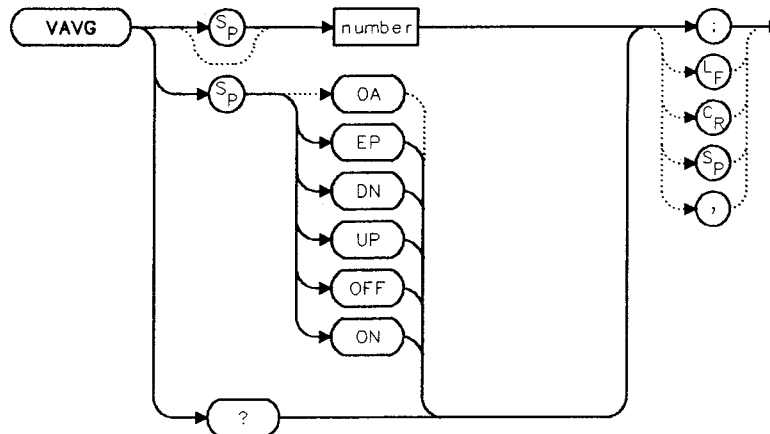

Description

The VAVG command activates the video averaging function. Video averaging smooths the displayed trace without using a narrow bandwidth. VAVG sets the IF detector to sample mode (see the DET command) and smooths the trace by averaging successive traces with each other. If desired, you can change the detector mode during video averaging.

Video averaging is available only for trace A, and trace A must be in clear-write mode for VAVG to operate. After VAVG is executed, the number of sweeps that have been averaged appears at the top of the analyzer screen.

Using video averaging allows you to view changes to the entire trace much faster than using narrow video filters. Narrow video filters require long sweep times, which may not be desired. Video averaging, though requiring more sweeps, uses faster sweep times; in some cases, it can produce a smooth trace as fast as a video filter.

Parameters

number integer from 1 to 999.
UP/DN increments by 1.

VAVG Video Average

Preset State

100, off

Query Response

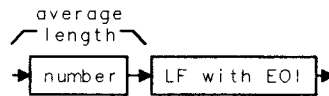

Example

```
10 OUTPUT 718;"SNGLS;VAVG 20;TS;"  
20 END
```

VB Video Bandwidth

Syntax

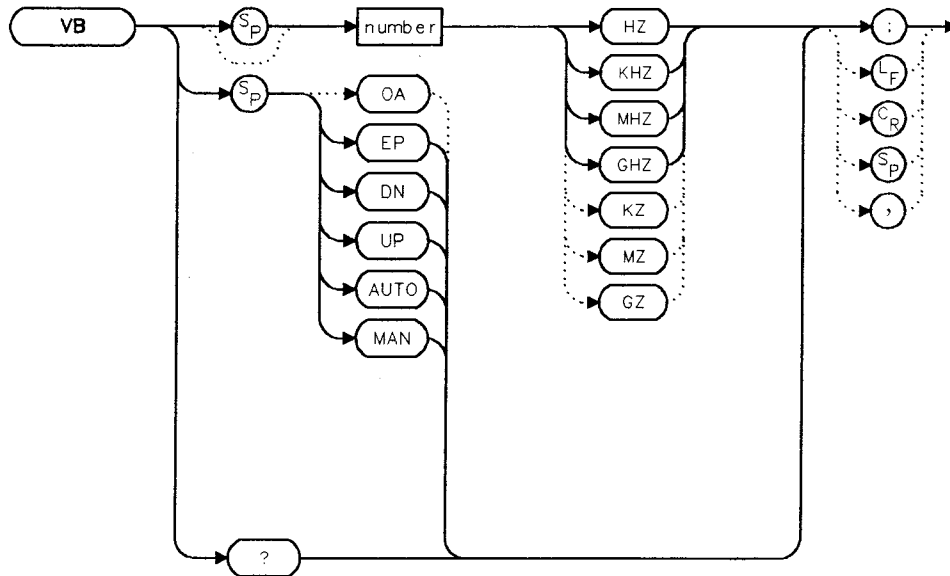

Description

The VB command specifies the video bandwidth. This is normally a coupled function that is selected according to the ratio selected by the VBR command. (If no ratio is selected, a default ratio, 1.0, is used instead.) Video bandwidths filter (or smooth) post-detected video information. The bandwidths, which range from 1 Hz to 3 MHz, may also be selected manually. If the specified video bandwidth is less than 300 Hz and the resolution bandwidth is greater than or equal to 300 Hz, the IF detector is set to sample mode.

Reducing the video bandwidth or increasing the number of video averages will usually smooth the trace by about as much for the same total measurement time. Reducing the video bandwidth to one-third or less of the resolution bandwidth is desirable when the number of video averages is above 25. For the case where the number of video averages is very large, and the video bandwidth is equal to the resolution bandwidth, internal mathematical limitations allow about 0.4 dB overresponse to noise on the logarithmic scale. The overresponse is negligible (less than 0.1 dB) for narrower video bandwidths.

VB Video Bandwidth

Parameters

number integer from 1 to 3E+6.
UP/DN increments in a 1, 3, 10 sequence.

Preset State

Coupled mode, 1 MHz

Query Response



Example

```
10 OUTPUT 718;"IP;"
20 OUTPUT 718;"CF 1.2GHZ;SP 2GHZ;"
30 INPUT "SELECT THE VIDEO BANDWIDTH, IN KHZ",B_width
40 OUTPUT 718;"VB ";B_width;"KHZ;"
50 OUTPUT 718;"VB?;"
60 ENTER 718;B_width
70 PRINT "SELECTED BANDWIDTH IS ",B_width,"HZ"
80 END
```

VBR Video Bandwidth to Resolution Bandwidth Ratio

Syntax

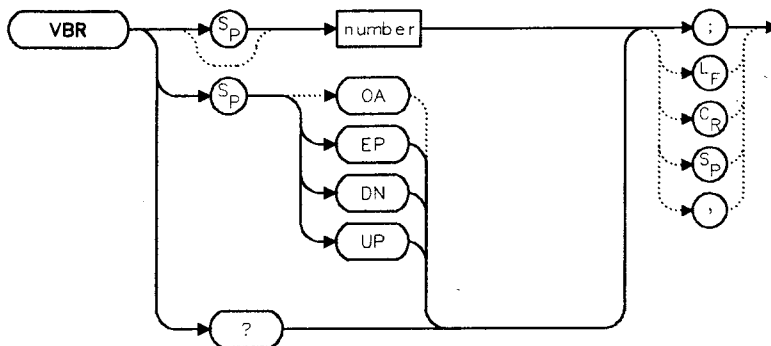

Description

The VBR command specifies the coupling ratio between the video bandwidth and the resolution bandwidth. Thus, when the resolution bandwidth is changed, the video bandwidth changes to satisfy the ratio. When a new ratio is selected, the video bandwidth changes to satisfy the new ratio—the resolution bandwidth does not change value.

Parameters

number real from 0.003 to 3.
 UP/DN increments in a 1, 3, 10 sequence.

Preset State

1

Query Response



VBR Video Bandwidth to Resolution Bandwidth Ratio

Example

```
10  OUTPUT 718;"IP;"
20  OUTPUT 718;"CF 1.2GHZ;SP 200MHZ;"
30  INPUT "SELECT THE VIDEO BANDWIDTH TO RESOLUTION
        BANDWIDTH RATIO",B_ratio
40  OUTPUT 718;"VBR ";B_ratio;";"
50  INPUT "SELECT THE RESOLUTION BANDWIDTH, IN KHZ",B_width
60  OUTPUT 718;"RB ";B_width;"KHZ;"
70  OUTPUT 718;"VB?;"
80  ENTER 718;B_width
90  PRINT "THE VIDEO BANDWIDTH IS ",B_width,"HZ"
100 END
```

VIEW

View Trace

Syntax

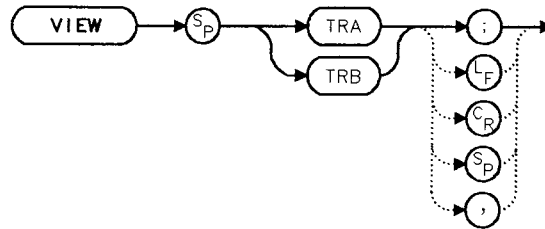

Description

The VIEW command displays the current contents of the selected trace, but does not update the contents. View mode may be executed before a sweep is complete when SNGLS and TS are not used. For more information on using SNGLS and TS, refer to Chapter 4.

Example

```
10 OUTPUT 718;"CLRW TRA;TS;VIEW TRA;"
20 END
```

VTL

Video Trigger Level

Syntax

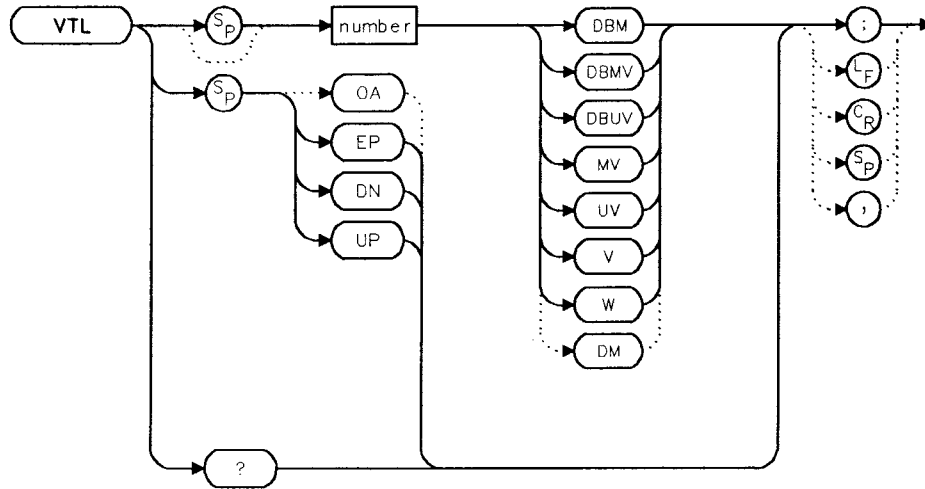

Description

The VTL commands sets the video trigger level when the trigger mode is set to VIDEO (refer to the TM command). A dashed line appears on the display to indicate the level. The default value is 0 dBm.

Parameters

number real from -220 to 30.
UP/DN increments by 1 vertical division.

Preset State

0 dBm

Query Response



Example

```
10  OUTPUT 718;"TM VID;"
20  OUTPUT 718;"VTL -20DBM;"
30  END
```

Instrument Preset State

The following table describes the factory-defined state that is stored in the memory of an HP 8560A, HP 8561B, and HP 8563A which cannot be changed.

Table A-5. Instrument State after **PRESET** Is Executed

Function	State
10 MHz REF	INTERNAL
A-B->A	OFF
A-B+DISPLAY LINE->A	OFF
AGC	OFF
ANNOTATION	ON
AUTO IF ADJUST	ON
BAND LOCK	OFF
CENTER FREQUENCY	1.45 GHz (HP 8560A); 3.25 GHz (HP 8561B); 12.38 GHz (HP 8563A)
CF STEP	290 MHz (HP 8560A); 650 MHz (HP 8561B); 1.925 GHz (HP 8563A); 2.375 GHz (HP 8563A Option 026)
DEMODULATION	FM OFF; AM OFF
DEMODULATION TIME	1 second
DETECTOR	NORMAL
DISPLAY LINE	0 dBm, OFF
EXT MIXER BIAS	0 mA
EXT MIXER LO HARMONIC	6
FREQUENCY COUNTER	OFF
FREQUENCY COUNTER RESOLUTION	10 kHz
FREQUENCY DISPLAY	ON
FREQUENCY MODE	CENTER-SPAN
FREQUENCY OFFSET	0 Hz

Table A-5. Instrument State after PRESET Is Executed (continued)

Function	State
GRATICULE	ON
INPUT ATTENUATION	10 dB, AUTO
MARKER MODE	OFF
MAX MIXER LEVEL	-10 dBm
MIXER	INT
MIXER CONV LOSS	30.0 dBm
NOISE MARKER	OFF
PEAK EXCURSION	6 dB
PEAK THRESHOLD	-130 dBm
PRESELECTOR PEAK TABLE	FACTORY DATA (HP 8561B, HP 8563A)
RBW/SPAN RATIO	0.011
REFERENCE LEVEL	0 dBm
REFERENCE LEVEL OFFSET	0 dB, OFF
RESOLUTION BW	1 MHz, AUTO
SIGNAL IDENTIFICATION	OFF
SIGNAL TRACK	OFF
SPAN	2.9 GHz (HP 8560A); 6.5 GHz (HP 8561B); 19.25 GHz (HP 8563A); 23.75 GHz (HP 8563A Option 026)
SQUELCH	OFF
SQUELCH LEVEL	-120 dBm
SWEEP TIME	60 ms, AUTO (HP 8560A); 200 ms, AUTO (HP 8561B); 400 ms, AUTO (HP 8563A); 500 ms, AUTO (HP 8563A Option 026)
THRESHOLD	-90 dBm, OFF
TRACE A	CLEAR-WRITE
TRACE B	BLANK
TRACE-DATA	FORMAT P
TRIGGER MODE	CONTINUOUS
TRIGGER SOURCE	FREE-RUN

Table A-5. Instrument State after (PRESET) Is Executed (continued)

Function	State
UNITS	dBm, AUTO
VERTICAL SCALE	10 dB/DIV
VBW/RBW RATIO	1
VIDEO BW	1 MHz, AUTO
VIDEO AVERAGE	100, OFF
VIDEO TRIG LEVEL	0 dBm

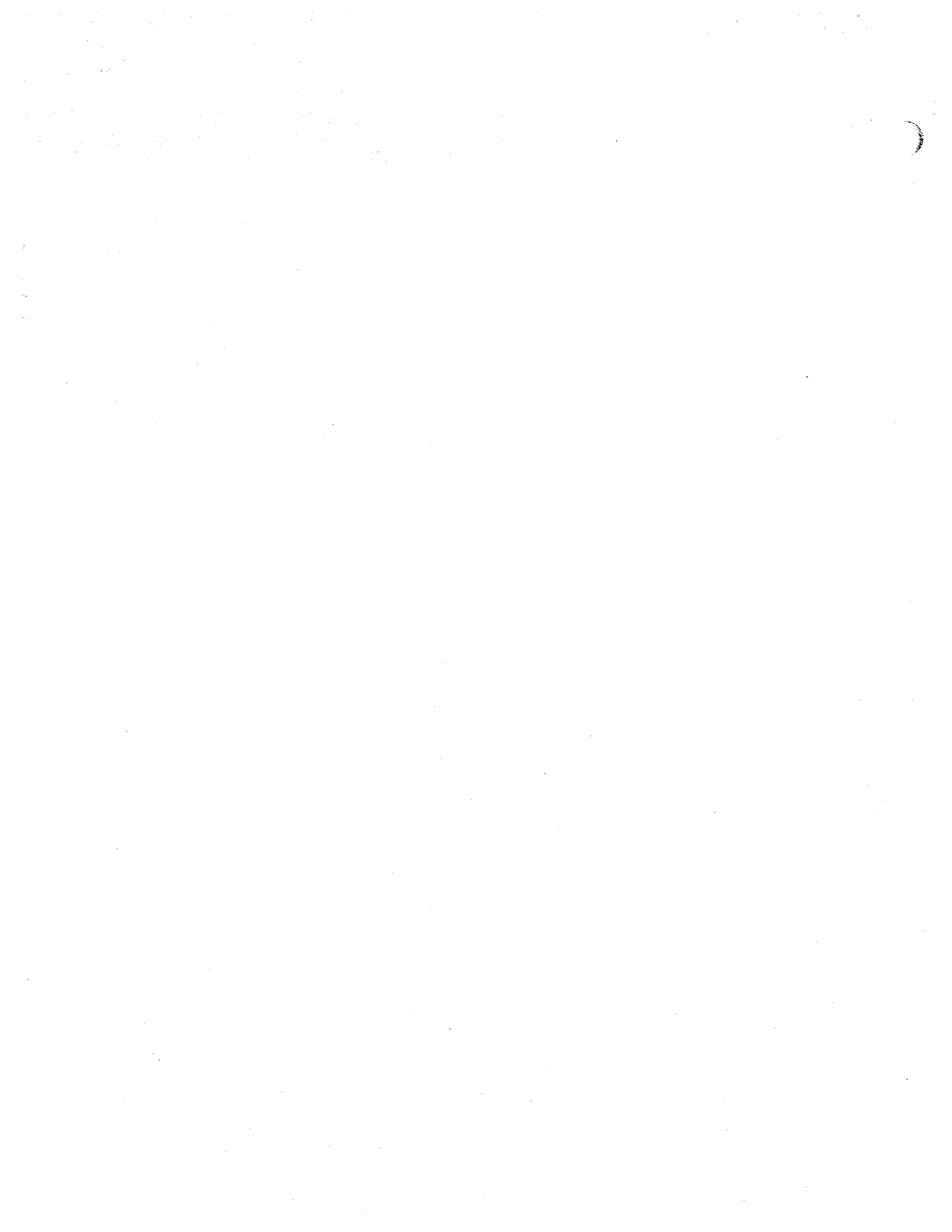

Softkey Cross Reference

This appendix lists the HP 8560A, HP 8561B, and HP 8563A softkeys in alphabetical order. Next to each softkey is the front-panel key under whose menu the softkey is found. Some softkeys are available on certain models only. Access to some marker softkeys may depend on the number of markers in use and the selected frequency span.

Table B-1. Softkey Cross Reference

Softkey	Front-Panel Key
0→10V LO SWP	AUX CTRL
0.5 V/GHz (FAV)	AUX CTRL
10 MHz EXT INT	AUX CTRL
12.5kHz/8.5kHz	MEAS/USER
20.0kHz/14.0kHz	MEAS/USER
25.0kHz/16.0kHz	MEAS/USER
3dB POINTS	MEAS/USER
6dB POINTS	MEAS/USER
A	
A+B→A	TRACE
A-B→A ON OFF	TRACE
A-B+DL→A ON OFF	TRACE
ACP COMPUTE	MEAS/USER
ACPGRAPH ON OFF	MEAS/USER
ACP MENU	MEAS/USER
ADJ CURR IF STATE	CAL
A EXCH B	TRACE
AGC ON OFF	AUX CTRL
ALC INT EXT*	AUX CTRL
ALL	AUTO COUPLE
AN DEMOD ON OFF	AUX CTRL
AN/FM DEMOD	AUX CTRL
AMPTD CORRECT †	AUX CTRL
AMPTD UNITS	AMPLITUDE
ANALYZER ADDRESS	CONFIG
<p>*Available only with an HP 8560A Option 002. †Not available with an HP 8560A Option 002.</p>	

Table B-1. Softkey Cross Reference (continued)

Softkey	Front-Panel Key
A (continued)	
ANNOT HELP	DISPLAY
ANNOT ON OFF	DISPLAY
ATTEN AUTO MAN †	AMPLITUDE, AUTO COUPLE
AUTO ACP MEASURE	MEAS/USER
AVERAGE CNV LOSS *	AUX CTRL
B	
B ← DL → B	TRACE
B & W	CONFIG
BACK SPACE	DISPLAY
BIAS *	AUX CTRL
BIAS OFF *	AUX CTRL
BLANK A	TRACE
BLANK B	TRACE
C	
CAL OPN/SHRT	AUX CTRL
CAL THRU	AUX CTRL
CENTER FREQ	FREQUENCY
CF STEP AUTO MAN	FREQUENCY, AUTO COUPLE
CHANNEL BANDWIDTH	MEAS/USER
CHANNEL SPACING	MEAS/USER
CHAR SFT 1 2	DISPLAY
CLEAR WRITE A	TRACE
CLEAR WRITE B	TRACE
CNV LOSS VS FREQ *	AUX CTRL
COLOR	CONFIG
CONT	SWEEP, TRIG
COPY DEV PRNT PLT	CONFIG
*Not available with an HP 8560A Option 002. †Available only with internal mixing.	

Table B-1. Softkey Cross Reference (continued)

Softkey	Front-Panel Key
C (continued)	
COUNTER ON OFF	FREQ COUNT
COUNTER RES	FREQ COUNT
COUPLING AC DC	AMPLITUDE
CRT ADJ PATTERN	CAL
D	
DATECODE & OPTIONS	CONFIG
dB μ V	AMPLITUDE
dBm	AMPLITUDE
dBmV	AMPLITUDE
DEMOD TIME	AUX CTRL
DETECTOR MODES	TRACE
DETECTOR NEG PEAK	TRACE
DETECTOR NORMAL	TRACE
DETECTOR POS PEAK	TRACE
DETECTOR SAMPLE	TRACE
DSPL LIN ON OFF	DISPLAY
E	
ELAPSED TIME	RECALL
ERASE TITLE	DISPLAY
EXIT ACP	MEAS/USER
EXTERNAL	TRIG
EXTERNAL MIXER*	AUX CTRL
EXT MIX PRE UNPR.*	CONFIG
F	
FACTORY PRSEL PK †	RECALL
FFT MEAS	MEAS/USER
*Not available with an HP 8560A Option 002. †Available only with internal mixing.	

Table B-1. Softkey Cross Reference (continued)

Softkey	Front-Panel Key
F (continued) FM DEMOD ON OFF FOCUS FREE RUN FREQ DIAGNOSE FREQ DSP OFF FREQ OFFSET FULL BAND* FULL IF ADJ FULL SPAN	AUX CTRL DISPLAY TRIG CAL DISPLAY FREQUENCY AUX CTRL CAL SPAN
G GRAT ON OFF	DISPLAY
I IF ADJ ON OFF INTENSTY INTERNAL MIXER*	CAL DISPLAY AUX CTRL
L LAST SPAN LAST STATE LINE LINEAR LOCK HARMONIC* LOCK ON OFF* LO FREQ LOG dB/DIV	SPAN PRESET, RECALL TRIG AMPLITUDE AUX CTRL AUX CTRL CAL AMPLITUDE
*Not available with an HP 8560A Option 002.	

Table B-1. Softkey Cross Reference (continued)

Softkey	Front-Panel Key
M	
MAIN ROLLER	CAL
MAN TRK ADJ *	AUX CTRL
MARKER → CF	MKR →, PEAK SEARCH
MARKER → CF STEP	MKR →
MARKER → REF LVL	MKR →
MARKER DELTA	AUX CTRL †, FREQ COUNT, MKR, PEAK SEARCH
MARKER 1/DELTA	MKR
MARKER NORMAL	AUX CTRL, FREQ COUNT, MKR, PEAK SEARCH †
MARKERS OFF	MKR
MAX HOLD A	TRACE
MAX HOLD B	TRACE
MAX MXR LEVEL ‡	AMPLITUDE
MKR Δ → CF §	MKR →
MKR Δ → CF STEP §	MKR →
MKR Δ → SPAN §	MKR →
MKR 1/Δ → CF †	MKR →
MKR 1/Δ → CF STEP †	MKR →
MRRNOISE ON OFF	MKR

*Available only with an HP 8560A Option 002.
 †Available when delta marker mode and zero span are in use.
 ‡Available only with internal mixing.
 §Available when delta marker mode is active.

Table B-1. Softkey Cross Reference (continued)

Softkey	Front-Panel Key
<p>N</p> <p>NEGATIVE BIAS*</p> <p>NEXT PEAK</p> <p>NEXT PK LEFT</p> <p>NEXT PK RIGHT</p> <p>NORMLIZE ON OFF</p> <p>NORM REF LVL †</p> <p>NORM REF POSN</p>	<p>AUX CTRL</p> <p>AUX CTRL, FREQ COUNT, PEAK SEARCH</p> <p>PEAK SEARCH</p> <p>PEAK SEARCH</p> <p>AUX CTRL, TRACE</p> <p>AMPLITUDE</p> <p>AMPLITUDE, AUX CTRL, TRACE</p>
<p>O</p> <p>OCCUPIED POWER BW</p> <p>OFFSET ROLLER</p>	<p>MEAS/USER</p> <p>CAL</p>
<p>P</p> <p>PEAK EXCURSN</p> <p>PEAK SEARCH</p> <p>PEAK THRESHLD</p> <p>PLOT ANNOT</p> <p>PLOT GRATICUL</p> <p>PLOT ORG DSP GRAT</p> <p>PLOTTER ADDRESS</p> <p>PLOTTER CONFIG</p> <p>PLOT TRACE A</p> <p>PLOT TRACE B</p> <p>POSITIVE BIAS*</p> <p>POWER ON</p>	<p>PEAK SEARCH</p> <p>AUX CTRL, FREQ COUNT</p> <p>PEAK SEARCH</p> <p>CONFIG</p> <p>CONFIG</p> <p>CONFIG</p> <p>CONFIG</p> <p>CONFIG</p> <p>CONFIG</p> <p>CONFIG</p> <p>CONFIG</p> <p>AUX CTRL</p> <p>RECALL</p>
<p>*Not available with an HP 8560A Option 002. †Softkey appears only when NORMLIZE ON OFF is set to ON.</p>	

Table B-1. Softkey Cross Reference (continued)

Softkey	Front-Panel Key
P (continued)	
PRESEL AUTO PK	AMPLITUDE, AUX CTRL
PRESEL MAN ADJ	AMPLITUDE, AUX CTRL
PRESEL PEAK †	AUX CTRL
PRINTER ADDRESS	CONFIG
PRINTER CONFIG	CONFIG
PWR ON STATE	SAVE
PWR SWP ON OFF †	AUX CTRL
R	
RANGE LVL	AMPLITUDE ‡, AUX CTRL
RBW/SPAN RATIO	BW
REALIGN LO & IF	CAL
RECALL ERRORS	RECALL
RECALL OPN/SHRT	AUX CTRL
RECALL PRESEL PR §	RECALL
RECALL STATE	RECALL
RECALL THRU	AUX CTRL
RECALL TO TR A	RECALL
RECALL TO TR B	RECALL
REAR PANEL	AUX CTRL
REF LVL	AMPLITUDE
REF LVL ADJ	CAL
REF LVL OFFSET	AMPLITUDE
RES BW AUTO MAN	AUTO COUPLE, BW
<p>*Available only with <i>preselected</i> external mixing. †Available only with an HP 8560A Option 002. ‡Softkey appears when NORMALIZE ON OFF is set to ON. §Available only with <i>preselected</i> external mixing and HP 8561B and HP 8563A internal mixing.</p>	

Table B-1. Softkey Cross Reference (continued)

Softkey	Front-Panel Key
S	
SAMPLER FREQ	CAL
SAMPLER HARMONIC	CAL
SAVELOCK ON OFF	SAVE
SAVE PRSEL PK*	SAVE
SAVE STATE	SAVE
SAVE TRACE A	SAVE
SAVE TRACE B	SAVE
SCREEN TITLE	DISPLAY
SELECT CHAR	DISPLAY
SIG ID AT MKR ††	AUX CTRL
SIG ID—CF ††	AUX CTRL
SID ID ON OFF ††	AUX CTRL
SIGNAL IDENT ††	AUX CTRL
SIG TRK ON OFF	MKR
SINGLE	SWEEP, TRIG
SOURCE CAL MENU	AUX CTRL
SPACE	DISPLAY
SPACING/BANDWIDTH	MEAS/USER
SPAN	SPAN
SPAN ZOOM	SPAN
SQUELCH ON OFF	AUX CTRL
SRC PWR OFFSET §	AUX CTRL
SRC PWR ON OFF §	AUX CTRL
SRC PWR STP SIZE §	AUX CTRL
<p>*Available only with preselected external mixing and HP 8561B and HP 8563A internal mixing. †Not available with an HP 8560A Option 002. ‡Available only with <i>unpreselected</i> external mixing. §Available only with an HP 8560A Option 002.</p>	

Table B-1. Softkey Cross Reference (continued)

Softkey	Front-Panel Key
S (continued) START FREQ STOP FREQ SWP CPL SR SA SWP TIME AUTO MAN	FREQUENCY FREQUENCY AUX CTRL AUTO COUPLE, SWEEP
T THRESHLD ON OFF TITLE DONE TRACE A B TRACKING GENRATOR TRACKING PEAK* TRANSFER ROLLER	DISPLAY DISPLAY TRACE AUX CTRL AUX CTRL CAL
U UNITS AUTO MAN	AMPLITUDE, AUTO COUPLE
V VBW/RBW RATIO VID AVG ON OFF VIDEO VIDEO BW AUTO MAN VIEW A VIEW B VOLTS	BW BW, TRACE TRIG AUTO COUPLE, BW TRACE TRACE AMPLITUDE
W WATTS	AMPLITUDE
Z ZERO SPAN	SPAN

*Available only with an HP 8560A Option 002.

Key versus Programming Command Cross Reference

This appendix lists the HP 8560A, HP 8561B, and HP 8563A keys in alphabetical order. Next to a key is the related programming command. In some cases, a key has no corresponding programming command.

Table C-1. Softkey Cross Reference

Key	Programming Command
0 → 10V LO SWP	SWPOUT
0.5 V/GHz (FAV)	SWPOUT
3dB POINTS	—
6dB POINTS	—
10 MHz EXT INT	FREF
12.5kHz/8.5kHz	—
20.0kHz/14.0kHz	—
25.0kHz/16.0kHz	—
A	
A+B → A	APB
A-B → A ON OFF	AMB
A-B+DL → A ON OFF	AMBPL
ACP COMPUTE	ACPCOMPUTE
ACPGRAPH ON OFF	ACPGRAPH
ACP MENU	—
A EXCH B	AXB
ADJ CURR IF STATE	ADJIF
AGC ON OFF	DEMODAGC
ALC INT EXT	SRCALC
ALL	AUTOCPPL
AM DEMOD ON OFF	DEMOD
AM/FM DEMOD	—
AMPLITUDE	RL
AMPTD CORRECT	—
AMPTD UNITS	AUNITS
ANALYZER ADDRESS	—
ANNOT HELP	—
ANNOT ON OFF	ANNOT

Table C-1. Softkey Cross Reference (continued)

Key	Programming Command
A (continued) ATTEM AUTO MAN AVERAGE CHV LOSS AUTO ACP MEASURE AUTO COUPLE AUX CTRL	AT CNVLOSS ACPMEAS — —
B B-DEL-B B & V BACK SPACE BIAS BIAS OFF BLANK A BLANK B BW	BML PRINT — MBIAS MBIAS BLANK BLANK RB
C CAL CAL OPN/SHRT CAL THRU CENTER FREQ CF STEP AUTO MAN CHANNEL BANDWIDTH CHANNEL SPACING CHAR SET 1 2 CLEAR WRITE A CLEAR WRITE B CHV LOSS VS FREQ COLOR CONFIG	— STOREOPEN, STORESHORT STORETHRU CF SS ACPBW ACPSP — CLRW CLRW — PRINT —

Table C-1. Softkey Cross Reference (continued)

Key	Programming Command
C (continued)	
CONT	CONTS
COPY	PLOT, PRINT
COPY DEV PRNT PLT	—
COUNTER ON OFF	MKFC
COUNTER RES	MKFCR
COUPLING AC DC	COUPLE
CRT ADJ PATTERN	ADJCRT
D	
DATECODE & OPTIONS	ID, REV, SER
dBμV	AUNITS
dBm	AUNITS
dBmV	AUNITS
DEMOD TIME	DEMODT
DETECTOR MODES	—
DETECTOR NEG PEAK	DET
DETECTOR NORMAL	DET
DETECTOR POS PEAK	DET
DETECTOR SAMPLE	DET
DSPL LIN ON OFF	DL
DISPLAY	—
E	
ELAPSED TIME	ET
ERASE TITLE	—
EXIT ACP	—
EXTERNAL	TM
EXTERNAL MIXER	MXRMODE
EXT MXR PRE UNPR	EXTMXR

Table C-1. Softkey Cross Reference (continued)

Key	Programming Command
F	
FACTORY PRSEL PR	—
FFT MEAS	FFT
FM DEMOD ON OFF	DEMOD
FOCUS	—
FREE RUN	TM
FREQ COUNT	MKFC
FREQ DIAGNOSE	FDIAG
FREQ DSE OFF	FDSP
FREQ OFFSET	FOFFSET
FREQUENCY	CF
FULL BAND	FULBAND
FULL IF ADJ	ADJIF
FULL SPAN	FS
G	
GRAT ON OFF	GRAT
H	
HOLD	HD
I	
IF ADJ ON OFF	ADJIF
INTENSTY	—
INTERNAL MIXER	MXRMODE
L	
LAST SPAN	—
LAST STATE	RCLS
LINE	TM
LINEAR	LN
LOCK HARMONIC	HNLOCK

Table C-1. Softkey Cross Reference (continued)

Key	Programming Command
L (continued)	
LOCK ON OFF	HNLOCK, HNUNLK
LO FREQ	FDIAG
LOG dB/DIV	LG
M	
MAIN ROLLER	FDIAG
MAN TRK ADJ	SRCCRSTK, SRCFINTK
MARKER → CF	MKCF
MARKER → CF STEP	MKSS
MARKER → REF LVL	MKRL
MARKER DELTA	MKD
MARKER 1/DELTA	MKDR
MARKER NORMAL	MKN
MARKERS OFF	MKOFF
MAX HOLD A	MXMH
MAX HOLD B	MXMH
MAX MKR LEVEL	ML
MEAS/USER	—
MKR	MKN
MKR →	MKN
MKR Δ → CF	MKCF
MKR Δ → CF STEP	MKSS
MKR Δ → SPAN	MKSP
MKR 1/Δ → CF	—
MKR 1/Δ → CF STEP	—
MKRNOISE ON OFF	MKNOISE
MODULE	—

Table C-1. Softkey Cross Reference (continued)

Key	Programming Command
<p>N</p> <p>NEGATIVE BIAS</p> <p>NEXT PEAK</p> <p>NEXT PK LEFT</p> <p>NEXT PK RIGHT</p> <p>NORMLIZE ON OFF</p> <p>NORM REF LVL</p> <p>NORM REF POSN</p>	<p>MBIAS</p> <p>MKPK</p> <p>MKPK</p> <p>MKPK</p> <p>MKPK</p> <p>NORMLIZE</p> <p>NRL</p> <p>NRPOS</p>
<p>O</p> <p>OCCUPIED POWER BW</p> <p>OFFSET ROLLER</p>	<p>PWRBW</p> <p>FDIAG</p>
<p>P</p> <p>PEAK EXCURSN</p> <p>PEAK SEARCH</p> <p>PEAK SEARCH</p> <p>PEAK THRSOLD</p> <p>PLOT ANNOT</p> <p>PLOT GRATICUL</p> <p>PLOT ORG DSP GRAT</p> <p>PLOTTER ADDRESS</p> <p>PLOTTER CONFIG</p> <p>PLOT TRACE A</p> <p>PLOT TRACE B</p> <p>POSITIVE BIAS</p> <p>POWER ON</p> <p>PRESEL AUTO PK</p> <p>PRESEL MAN ADJ</p>	<p>MKPX</p> <p>MKPK</p> <p>MKPK</p> <p>MKPT</p> <p>PLOTSRC</p> <p>PLOTSRC</p> <p>PLOTORG</p> <p>—</p> <p>PLOTSRC</p> <p>PLOTSRC</p> <p>PLOTSRC</p> <p>MBIAS</p> <p>RCLS</p> <p>PP</p> <p>PSDAC</p>

Table C-1. Softkey Cross Reference (continued)

Key	Programming Command
P (continued) PRESEL PEAK PRESET PRINTER ADDRESS PRINTER CONFIG PWR ON STATE PWR SWP ON OFF	— IP — — SAVES SRCPSWP
R RANGE LVL RBW/SPAN RATIO REALIGN LO & IF RECALL RECALL ERRORS RECALL OPN/SHRT RECALL PRSEL PK RECALL STATE RECALL THRU RECALL TO TR A RECALL TO TR B REAR PANEL REF LVL REF LVL ADJ REF LVL OFFSET RES BW AUTO MAN	RL RBR ADJALL — ERR RCLOSCAL — RCLS RCLTHRU RCLT RCLT — RL RLCAL ROFFSET RB
S SAMPLER FREQ SAMPLER HARMONIC SAVE	FDIAG FDIAG —

Table C-1. Softkey Cross Reference (continued)

Key	Programming Command
S (continued)	
SAVELOCK ON OFF	PSTATE
SAVE PRSEL PR	—
SAVE STATE	SAVES
SAVE TRACE A	SAVET
SAVE TRACE B	SAVET
SCREEN TITLE	TITLE
SELECT CHAR	—
SGL SWP	SNGLS
SIG ID AT MKR	SIGID
SID ID ON OFF	SIGID
SIG ID—CF	IDCF
SIGNAL IDENT	—
SIG TRK ON OFF	MKTRACK
SINGLE	SNGLS
SOURCE CAL MENU	—
SPACE	—
SPACING/BANDWDTH	—
SPAN	SP
SPAN	SP
SQUELCH ON OFF	SQUELCH
SRC PWR OFFSET	SRCPOFS
SRC PWR ON OFF	SRCPWR
SRC PWR STP SIZE	SRCPSTP
START FREQ	FA
STOP FREQ	FB
SWEEP	ST
SWP CPL SR SA	SWPCPL
SWP TIME AUTO MAN	ST

Table C-1. Softkey Cross Reference (continued)

Key	Programming Command
<p>T</p> <p>THRESHLD ON OFF</p> <p>TITLE DONE</p> <p>TRACE</p> <p>TRACE A B</p> <p>TRACKING GENRATOR</p> <p>TRACKING PEAR</p> <p>TRANSFER ROLLER</p> <p>TRIG</p>	<p>TH</p> <p>TITLE</p> <p>—</p> <p>TRA, TRB</p> <p>—</p> <p>SRCTKPK</p> <p>FDIAG</p> <p>—</p>
<p>U</p> <p>UNITS AUTO MAN</p>	<p>AUNITS</p>
<p>V</p> <p>VBW/RBW RATIO</p> <p>VID AVG ON OFF</p> <p>VIDEO</p> <p>VIDEO BW AUTO MAN</p> <p>VIEW A</p> <p>VIEW B</p> <p>VOLTS</p>	<p>VBR</p> <p>VAVG</p> <p>TM, VTL</p> <p>VB</p> <p>VIEW</p> <p>VIEW</p> <p>AUNITS</p>
<p>W</p> <p>WATTS</p>	<p>AUNITS</p>
<p>Z</p> <p>ZERO SPAN</p>	<p>SP</p>

Programming Command versus Key

This appendix lists HP 8560A, HP 8561B, and HP 8563A programming commands. The programming commands are listed in alphabetical order, followed by a brief command name, and (if applicable) the corresponding key.

Table D-1. Command versus Key

Command	Name	Key
ACPBW	Adjacent Channel Power Bandwidth	CHANNEL BANDWIDTH
ACPCOMPUTE	Compute Adjacent Channel Power	ACP COMPUTE
ACPGRAPH	Adjacent Channel Power Graph	ACPGRAPH ON OFF
ACPLOWER	Lower Adjacent Channel Power	—
ACPMAX	Maximum Adjacent Channel Power	—
ACPMEAS	Measure Adjacent Channel Power	AUTO ACP MEASURE
ACPPWRTX	Total Power Transmitted	—
ACPSP	Adjacent Channel Power Spacing	CHANNEL SPACING
ACPUPPER	Upper Adjacent Channel Power	—
ADJALL	Execute LO and IF Adjustments	REALIGN LO & IF
ADJCRT	Adjust CRT Alignment	CRT ADJ PATTERN
ADJIF	Adjust IF	ADJ CURR IF STATE, FULL IF ADJ, IF ADJ ON OFF
AMB	Trace A Minus Trace B	A-B→A ON OFF
AMBPL	Trace A Minus Trace B Plus Display Line	A-B+DL→A ON OFF
ANNOT	Annotation On/Off	ANNOT ON OFF
APB	Trace A Plus Trace B	A+B→A
AT	Input Attenuation	ATTEN AUTO MAN
AUNITS	Absolute Amplitude Units	UNITS AUTO MAN
AUTOCP	Autocouple All "AUTO" Functions	ALL
AXB	Trace A Exchange Trace B	A EXCH B
BLANK	Blank Trace	BLANK A, BLANK B
BML	Trace B Minus Display Line	B-DL→B
CF	Center Frequency	CENTER FREQ, FREQUENCY
CLRW	Clear/Write Trace	CLEAR WRITE A, CLEAR WRITE B
CNVLOSS	External Mixer Conversion Loss	AVERAGE CNV LOSS
CONTS	Continuous Sweep	CONT
COUPLE	Input Coupling	COUPLING AC DC
DEMODO	Demodulation	AM DEMOD ON OFF, FM DEMOD ON OFF
DEMODAGC	Demodulation Automatic Gain Control	AGC ON OFF

Table D-1. Command versus Key (continued)

Command	Name	Key
DEMODT	Demodulation Time	DEM OD TIME
DET	Detection Mode	DETECTOR MODES
DL	Display Line	DSPL LIN ON OFF
DONE	Done	—
ERR	Error	RECALL ERRORS
ET	Elapsed Time	ELAPSED TIME
EXTMXR	External Mixer Mode	EXT MIX PRK UNPR
FA	Start Frequency	START FREQ
FB	Stop Frequency	STOP FREQ
FDIAG	Frequency Diagnostics	FREQ DIAGNOSE
FDSP	Frequency Display	FREQ DSP OFF
FFT	Fast Fourier Transform	FFT MEAS
FOFFSET	Frequency Offset	FREQ OFFSET
FREF	Frequency Reference	10 MHz INT EXT
FS	Full Span	FULL SPAN
FULBAND	Full Band	FULL BAND
GRAT	Graticule On/Off	GRAT ON OFF
HD	Hold	(HOLD)
HNLOCK	Harmonic Number Lock	LOCK HARMONIC, LOCK ON OFF
HNUNLK	Unlock Harmonic Number	LOCK ON OFF
ID	Output Identification	DATECODE OPTIONS
IDCF	Signal Identification Frequency to Center Frequency	SIG ID—CF
IDFREQ	Signal Identified Frequency	—
IP	Instrument Preset	(PRESET)
LG	Logarithmic Amplitude Scale	LOG dB/DIV
LN	Linear Amplitude Scale	LINEAR
MBIAS	Mixer Bias	BIAS OFF, NEGATIVE BIAS, POSITIVE BIAS

Table D-1. Command versus Key (continued)

Command	Name	Key
MINH	Minimum Trace Hold	—
MKA	Marker Amplitude	—
MKCF	Marker to Center Frequency	MARKER → CF
MKD	Marker Delta	MARKER DELTA
MKDR	Marker Delta Reciprocal	MARKER 1/DELTA
MKF	Marker Frequency	—
MKFC	Frequency Counter	COUNTER ON OFF, (FREQ COUNT)
MKFCR	Frequency Counter Resolution	COUNTER RES
MKMIN	Marker to Minimum	—
MKN	Marker Normal	MARKER NORMAL, (MKR), (MKR→)
MKNOISE	Marker Noise	MKRNOISE ON OFF
MKOFF	Markers Off	MARKERS OFF
MKPK	Marker Peak Search	(PEAK SEARCH), PEAK SEARCH
MKPT	Marker Peak Threshold	PEAK THRESHLD
MKPX	Marker Peak Excursion	PEAK EXCURSN
MKRL	Marker to Reference Level	MARKER → REF LVL
MKSP	Marker Delta to Span	MKR Δ → SPAN
MKSS	Marker to Center Frequency Step-Size	MARKER → CF STEP
MKT	Marker Time	MARKER NORMAL (when span = 0 Hz)
MKTRACK	Signal Track	SIG TRK ON OFF
ML	Mixer Level	MAX MKR LEVEL
MXMH	Maximum Hold	MAX HOLD A, MAX HOLD B
MXRMODE	Mixer Mode	EXTERNAL MIXER, INTERNAL MIXER
NORMLIZE	Normalized Trace Data	NORMLIZE ON OFF
NRL	Normalize Reference Level	NORM REF LVL
NRPOS	Adjust Normalized Reference Level	NORM REF POSN
OP	Output Display Parameters	—

Table D-1. Command versus Key (continued)

Command	Name	Key
PLOT	Plot Display	COPY
PLOTORG	Specify Plot Origins	PLOT ORG DSP GRAT
PLOTSRC	Plot Source	PLOTTER CONFIG
PP	Preselector Peak	PRESEL AUTO PK
PRINT	Print Display	COPY
PSDAC	Preselector DAC Number	PRESEL MAN ADJ
PSTATE	Protect State	SAVELOCK ON OFF
PWRBW	Trace Power Bandwidth	POWER BANDWIDTH
RB	Resolution Bandwidth	BW , RES BW AUTO MAN
RBR	Resolution Bandwidth to Span Ratio	RBW/SPAN RATIO
RCLOSCAL	Recall Open/Short Average	RECALL OPN/SHRT
RCLS	Recall State Register	RECALL STATE
RCLT	Recall Trace Register	RECALL TO TRA , RECALL TO TRB
RCLTHRU	Recall Thru	RECALL THRU
REV	Output Firmware Revision	DATECODE & OPTIONS
RL	Reference/Range Level	AMPLITUDE , RANGE LVL , REF LVL
RLCAL	Reference Level Calibration	REF LVL ADJ
ROFFSET	Reference Amplitude Offset	REF LVL OFFSET
RQS	Request Service Conditions	—
SAVES	Save State	SAVE STATE
SAVET	Save Trace	SAVE TRACE A , SAVE TRACE B
SER	Serial Number	DATECODE & OPTIONS
SIGID	Signal Identify	SIG ID AT MKR , SIG ID ON OFF
SNGLS	Single Sweep	SGL SWP , SINGLE
SP	Frequency Span	SPAN , SPAN
SQUELCH	Squelch for Demodulation	SQUELCH ON OFF
SRCALC	Source Leveling Control	ALC INT EXT
SRCCRSTK	Coarse Tracking Adjust	MAN TRK ADJ

Table D-1. Command versus Key (continued)

Command	Name	Key
SRCFINTK	Fine Tracking Adjust	MAN TRK ADJ
SRCPOFS	Source Power Offset	SRC PWR OFFSET
SRCPSTP	Source Power Step-Size	SRC PWR STP SIZE
SRCPSWP	Tracking Generator Power Sweep	PWR SWP ON OFF
SRCPWR	Tracking Generator Output Power	SRC PWR ON OFF
SRCTKPK	Peak Tracking Generator Response	TRACKING PEAK
SRQ	Service Request	—
SS	Center Frequency Step-Size	CF STEP AUTO MAN
ST	Sweep Time	SWP TIME AUTO MAN
STB	Status Byte Query	—
STOREOPEN	Store Open	CAL OPN/SHRT
STORESHORT	Store Short	CAL OPN/SHRT
STORETHRU	Store Thru	CAL THRU
SWPCPL	Stimulus-Response Sweep Couple	SWP CPL SR SA
SWPOUT	Sweep Output	0.5 V/GHz (FAV)
TDF	Trace Data Format	—
TH	Threshold	THRESHLD ON OFF
TITLE	Title Entry	SCREEN TITLE
TM	Trigger Mode	TRIG
TRA	Trace A Data Input/Output	—
TRB	Trace B Data Input/Output	—
TS	Take Sweep	—
TWINDOW	Trace window	—
VAVG	Video Average	VID AVG ON OFF
VB	Video Bandwidth	VIDEO BW AUTO MAN
VBR	Video Bandwidth to Resolution Bandwidth Ratio	VBW/RBW RATIO
VIEW	View Trace	VIEW A, VIEW B
VTL	Video Trigger Level	VIDEO

Error Messages

Error messages are displayed in the lower right-hand corner of the analyzer's display. A number, or error code, is associated with each error message. Several error codes can correspond to the same error message. These codes are basically provided for service personnel who troubleshoot the spectrum analyzer, however, they also alert the user to errors in spectrum analyzer function or use. Error codes are set up in the following categories:

100 to 199	Programming errors
200 to 299	ADC failures
300 to 399	LO or RF failures
400 to 599	IF failures
600 to 699	Display failures
700 to 799	Digital failures
800 to 899	Option module failures
900 to 999	User generated errors

Eliminating Error Messages

It might be possible to eliminate some error messages by performing a **REALIGN LO & IF** sequence. Follow this procedure:

1. Press **(SAVE)**, then **SAVE STATE**.
2. Store the current state in a convenient STATE register.
3. Press **(PRESET)**, **(CAL)**, then **REALIGN LO & IF**. Wait for the sequence to finish.
4. Press **(RECALL)**, then **RECALL STATE**.
5. Recall the previously stored STATE.

If any error message remains displayed the following actions are suggested:

Error	Action
100 to 199	Programming error detected, refer to the <i>HP 8560A/8561B/8563A Spectrum Analyzer Operating Manual</i> for information on programming the spectrum analyzer.
200 to 799	The instrument is in need of service. Refer to Chapter 2 "Preparation" for information about calling Hewlett Packard.

- | | |
|------------|--|
| 800 to 899 | Option module failures detected. Refer to the appropriate option-module for an explanation of these errors. |
| 900 to 999 | User generated errors. Information entered incorrectly or an attempt to use the spectrum analyzer inappropriately. |

Recording Error Messages

If returning the analyzer for repair is necessary, include a list of any error codes and messages that appeared when the trouble began. These codes and messages provide troubleshooting information for the service person working on the analyzer.

Viewing Multiple Messages

The spectrum analyzer displays only one error message at a time. More error messages may exist. To check for more error messages, proceed as follows:

1. Press **RECALL**, then **MORE 1 OF 2**.
2. Press **RECALL ERRORS**. An error message is displayed in the active function block on the analyzer display.
3. Use the **▲** and **▼** keys to scroll through any other error messages which might exist, making note of each error code.

Error Code Listing

Error codes and their associated messages are listed in numeric order below.

Error codes 100 to 199 relate to incorrect spectrum analyzer programming

ERR 100 NO PWRON	Power-on state is invalid; default state is loaded.
ERR 101 NO STATE	State to be RECALLED not valid or not SAVED.
ERR 106 ABORTED!	Current operation is aborted; HP-IB parser reset.
ERR 107 HELLO ??	No HP-IB listener is present.
ERR 108 TIME OUT	Analyzer timed out when acting as controller.
ERR 109 CtrlFail	Analyzer unable to take control of the bus.
ERR 110 NOT CTRL	Analyzer is not system controller.
ERR 111 # ARGMTS	Command does not have enough arguments.
ERR 112 ??CMD??	Unrecognized command.
ERR 113 FREQ NO!	Command cannot have frequency units.
ERR 114 TIME NO!	Command cannot have time units.
ERR 115 AMPL NO!	Command cannot have amplitude units.
ERR 116 ?UNITS??	Unrecognizable units.
ERR 117 NOP NUM	Command cannot have numeric units.
ERR 118 NOP EP	Enable parameter cannot be used.
ERR 119 NOP UPDN	UP/DN are not valid arguments for this command.
ERR 120 NOP ONOF	ON/OFF are not valid arguments for this command.
ERR 121 NOP ARG	AUTO/MAN are not valid arguments for this command.
ERR 122 NOP TRC	Trace registers are not valid for this command.
ERR 123 NOP ABLK	A-block format not valid here.

ERR 124 NOP IBLK	I-block format not valid here.
ERR 125 NOP STRNG	Strings are not valid for this command.
ERR 126 NO ?	This command cannot be queried.
ERR 127 BAD DTMD	Not a valid peak detector mode.
ERR 128 PK WHAT?	Not a valid peak search parameter.
ERR 129 PRE TERM	Premature A-block termination.
ERR 130 BAD TDF	Arguments are only for TDF command.
ERR 131 ?? AM/FM	AM/FM are not valid arguments for this command.
ERR 132 !FAV/RMP	FAV/RAMP are not valid arguments for this command.
ERR 133 !INT/EXT	INT/EXT are not valid arguments for this command.
ERR 134 ??? ZERO	ZERO is not a valid argument for this command.
ERR 135 ??? CURR	CURR is not a valid argument for this command.
ERR 136 ??? FULL	FULL is not a valid argument for this command.
ERR 137 ??? LAST	LAST is not a valid argument for this command.
ERR 138 !GRT/DSP	GRT/DSP are not valid arguments for this command.
ERR 139 PLOTONLY	Argument can only be used with PLOT command.
ERR 140 ?? PWRON	PWRON is not a valid argument for this command.
ERR 141 BAD ARG	Argument can only be used with FDIAG command.
ERR 142 BAD ARG	Query expected for FDIAG command.
ERR 143 NO PRESL	No preselector hardware to use command with.
ERR 144 COUPL??	Invalid COUPLING argument, expected AC or DC.

E-4 Error Messages

Error codes 200 through 299 relate to ADC hardware/firmware failures. Instrument service is required.

ERR 200 ADC Driver/ADC Hardware/firmware interaction; check for other errors.
SYSTEM

ERR 201 ADC Controller/ADC Hardware/firmware interaction; check for other errors.
SYSTEM

ERR 250 ADC input is outside of ADC range.
OUTOF RG

ERR 251 Microprocessor not receiving interrupt from ADC.
NO IRQ

Error codes 300 through 399 relate to LO and RF hardware/firmware failures. Instrument service is required.

ERR 300 YTO (1ST LO) phase-locked loop (PLL) is unlocked.
YTO UNLK

ERR 301 YTO PLL is unlocked.
YTO UNLK

ERR 302 Offset Roller Oscillator PLL is unlocked.
OFF UNLK

ERR 303 Transfer Roller Oscillator PLL is unlocked.
XFR UNLK

ERR 304 Main Roller Oscillator PLL is unlocked.
ROL UNLK

ERR 305 Course Adjust DAC cannot bring MAINSENSE close to zero
FREQ ACC

ERR 306 Fine Adjust DAC cannot bring MAINSENSE close to zero
FREQ ACC

ERR 307 Transfer Oscillator Pretune DAC out of range
FREQ ACC

ERR 308 Offset Oscillator Pretune DAC not within prescribed limits at low frequency
FREQ ACC

ERR 309 Offset Oscillator Pretune DAC not within prescribed limits at high frequency
FREQ ACC

ERR 310 Main Roller Pretune DAC set to 255 before MAINSENSE changes to negative
FREQ ACC polarity

ERR 311 Main Roller Pretune DAC set to 255 before MAINSENSE changes to negative
FREQ ACC polarity

ERR 312 Fine Adjust DAC cannot bring MAINSENSE close to zero.
FREQ ACC

ERR 313 The combination of Sampler Oscillator and Roller Oscillator frequencies do
FREQ ACC not correspond to the required YTO start frequency.

ERR 314 Span calibration problems. An unlocked Main Roller loop or lack of a sweep
FREQ ACC ramp.

ERR 315 Span calibration problems. Roller Span Attenuator DAC is out of range.
FREQ ACC

ERR 316 Sensitivity of the Main Roller DAC is zero.
 FREQ ACC

ERR 317 Main Coil Course DAC at limits.
 FREQ ACC

ERR 318 Main Coil Fine DAC at limits.
 FREQ ACC

ERR 321 Main Roller tuning sensitivity is not greater than zero.
 FREQ ACC

ERR 322 Main Roller Pretune DAC value set greater than 255.
 FREQ ACC

ERR 324 Course Adjust DAC cannot bring MAINSENSE close to zero
 FREQ ACC

ERR 325 Fine Adjust DAC cannot bring MAINSENSE close to zero
 FREQ ACC

ERR 326 Fine Adjust DAC near the end of range.
 FREQ ACC

ERR 327 Offset Roller Oscillator PLL is unlocked.
 OFF UNLK

ERR 328 Roller Fine Adjust DAC sensitivity less than or equal to zero.
 FREQ ACC

ERR 329 Roller Course Adjust DAC sensitivity less than or equal to zero.
 FREQ ACC

ERR 331 Invalid YTO frequency
 FREQ ACC

ERR 333 600 MHz Reference Oscillator PLL is unlocked.
 600 UNLK

ERR 334 1st LO Distribution Amplifier is unlevelled.
 LO AMPL

ERR 335 Sampling Oscillator PLL is unlocked.
 SMP UNLK

ERR 336 Cal Oscillator failed to lock when going to internal 10 MHz reference
 10 MHz Ref

Error codes 400 through 599 relate to IF failures. Instrument service is required

These errors are generated when the automatic IF adjustment routine detects a fault. These errors are designed to assist service personnel in IF problem isolation, however, an instrument will function if the suspect functional parameters are not required. This routine adjusts amplitude parameters first, then resolution bandwidths in this sequence: 300 kHz, 1 MHz, 2 MHz, 100 kHz, 30 kHz, 10 kHz, 3 kHz, 1 kHz, 300 Hz, 100 Hz, 30 Hz, and 10 Hz. The routine restarts from the beginning if a fault is detected.

Resolution bandwidth filters adjusted after the routine begins and before the fault is detected should be acceptable; resolution bandwidth filters adjusted later in the sequence are suspect.

If the fault is detected before the first resolution bandwidth (300 kHz) is adjusted, all IF performance is suspect.

ERR 400 Unable to adjust amplitude of 100 Hz RES BW.
 AMPL 100

E-6 Error Messages

ERR 401 AMPL 300	Unable to adjust amplitude of 300 Hz RES BW.
ERR 402 AMPL 1K	Unable to adjust amplitude of 1 kHz RES BW.
ERR 403 AMPL 3K	Unable to adjust amplitude of 3 kHz RES BW.
ERR 404 AMPL 10K	Unable to adjust amplitude of 10 kHz RES BW.
ERR 405 RBW 10K	Unable to adjust 10 kHz RES BW Pole 1.
ERR 406 RBW 10K	Unable to adjust 10 kHz RES BW Pole 2.
ERR 407 RBW 10K	Unable to adjust 10 kHz RES BW Pole 3.
ERR 408 RBW 10K	Unable to adjust 10 kHz RES BW Pole 4.
ERR 409 RBW 10K	Unable to adjust 10 kHz RES BW Pole 1.
ERR 410 RBW 10K	Unable to adjust 10 kHz RES BW Pole 2.
ERR 411 RBW 10K	Unable to adjust 10 kHz RES BW Pole 3.
ERR 412 RBW 10K	Unable to adjust 10 kHz RES BW Pole 4.
ERR 413 RBW 10K	Unable to adjust 10 kHz RES BW. No cross PT Pole 1.
ERR 414 RBW 10K	Unable to adjust 10 kHz RES BW. No cross PT Pole 2.
ERR 415 RBW 10K	Unable to adjust 10 kHz RES BW. No cross PT Pole 3.
ERR 416 RBW 10K	Unable to adjust 10 kHz RES BW. No cross PT Pole 4.
ERR 417 RBW 3K	Unable to adjust 3 kHz RES BW. No cross PT Pole 1.
ERR 418 RBW 3K	Unable to adjust 3 kHz RES BW. No cross PT Pole 2.
ERR 419 RBW 3K	Unable to adjust 3 kHz RES BW. No cross PT Pole 3.
ERR 420 RBW 3K	Unable to adjust 3 kHz RES BW. No cross PT Pole 4.
ERR 421 RBW 10K	Unable to adjust 10 kHz RES BW. Cross PT RG Pole 1.
ERR 422 RBW 10K	Unable to adjust 10 kHz RES BW. Cross PT RG Pole 2.

ERR 423 RBW 10K	Unable to adjust 10 kHz RES BW. Cross PT RG Pole 3.
ERR 424 RBW 10K	Unable to adjust 10 kHz RES BW. Cross PT RG Pole 4.
ERR 425 RBW 3K	Unable to adjust 3 kHz RES BW. Cross PT RG Pole 1.
ERR 426 RBW 3K	Unable to adjust 3 kHz RES BW. Cross PT RG Pole 2.
ERR 427 RBW 3K	Unable to adjust 3 kHz RES BW. Cross PT RG Pole 3.
ERR 428 RBW 3K	Unable to adjust 3 kHz RES BW. Cross PT RG Pole 4.
ERR 429 RBW 100	Unable to adjust 100 Hz RES BW. ADC Handshake
ERR 430 RBW 300	Unable to adjust 300 Hz RES BW. ADC Handshake
ERR 431 RBW 1K	Unable to adjust 1 kHz RES BW. ADC Handshake
ERR 432 RBW 3K	Unable to adjust 3 kHz RES BW. ADC Handshake
ERR 433 RBW 10K	Unable to adjust 10 kHz RES BW. ADC Handshake
ERR 434 RBW 300	Unable to adjust 300 Hz RES BW. LO Amplitude Pole 1.
ERR 435 RBW 300	Unable to adjust 300 Hz RES BW. LO Amplitude Pole 2.
ERR 436 RBW 300	Unable to adjust 300 Hz RES BW. LO Amplitude Pole 3.
ERR 437 RBW 300	Unable to adjust 300 Hz RES BW. LO Amplitude Pole 4.
ERR 438 RBW 1K	Unable to adjust 1 kHz RES BW. LO Amplitude Pole 1.
ERR 439 RBW 1K	Unable to adjust 1 kHz RES BW. LO Amplitude Pole 2.
ERR 440 RBW 1K	Unable to adjust 1 kHz RES BW. LO Amplitude Pole 3.
ERR 441 RBW 1K	Unable to adjust 1 kHz RES BW. LO Amplitude Pole 4.
ERR 442 RBW 3K	Unable to adjust 3 kHz RES BW. LO Amplitude Pole 1.
ERR 443 RBW 3K	Unable to adjust 3 kHz RES BW. LO Amplitude Pole 2.
ERR 444 RBW 3K	Unable to adjust 3 kHz RES BW. LO Amplitude Pole 3.

E-8 Error Messages

ERR 445 RBW 3K	Unable to adjust 3 kHz RES BW. LO Amplitude Pole 4.
ERR 446 RBW 10K	Unable to adjust 10 kHz RES BW. LO Amplitude Pole 1.
ERR 447 RBW 10K	Unable to adjust 10 kHz RES BW. LO Amplitude Pole 2.
ERR 448 RBW 10K	Unable to adjust 10 kHz RES BW. LO Amplitude Pole 3.
ERR 449 RBW 10K	Unable to adjust 10 kHz RES BW. LO Amplitude Pole 4.
ERR 450 IF SYSTM	IF hardware failure. Check other error messages.
ERR 451 IF SYSTM	IF hardware failure. Check other error messages.
ERR 452 IF SYSTM	IF hardware failure. Check other error messages.
ERR 454 AMPL	Linear to Log utility. Check other errors.
ERR 455 AMPL	Lin to Log conversion, fine gain, AMPL1.
ERR 456 AMPL	Lin to Log conversion, fine gain, AMPL2.
ERR 457 AMPL	Lin to Log conversion, fine gain, AMPL3
ERR 458 AMPL	Lin to Log conversion, step gain 1, AMPL4
ERR 459 AMPL	Lin to Log conversion, step gain 1, AMPL5
ERR 460 AMPL	Lin to Log conversion, step gain 1, AMPL6
ERR 461 AMPL	Lin to Log conversion, step gain 2, AMPL7
ERR 462 AMPL	Lin to Log conversion, step gain 2, AMPL8
ERR 463 AMPL	Lin to Log conversion, course gain, AMPL9
ERR 464 AMPL	Lin to Log conversion, course gain, AMPL10
ERR 465 AMPL	Lin to Log conversion, course gain, AMPL11
ERR 466 LIN AMPL	Unable to adjust linear amplitude scale. AMPL12.
ERR 467 LOG AMPL	Unable to adjust log amplitude scale. AMPL13.

ERR 468	Unable to adjust log amplitude scale. AMPL14.
LOG AMPL	
ERR 469	Unable to adjust log amplitude scale. AMPL15
LOG AMPL	
ERR 470	Unable to adjust log amplitude scale. AMPL16.
LOG AMPL	
ERR 471	Unable to adjust 30 kHz RES BW. Lin to Log LC1
RBW 30K	
ERR 472	Unable to adjust 100 kHz RES BW. Lin to LOG LC1.
RBW 100K	
ERR 473	Unable to adjust 300 kHz RES BW. Lin to Log LC1.
RBW 300K	
ERR 474	Unable to adjust 1 MHz RES BW. Lin to Log LC1.
RBW 1M	
ERR 475	Unable to adjust 30 kHz RES BW. Lin to Log LC2.
RBW 30K	
ERR 476	Unable to adjust 100 kHz RES BW. Lin to Log LC2.
RBW 100K	
ERR 477	Unable to adjust 300 kHz RES BW. Lin to Log LC2.
RBW 300K	
ERR 478	Unable to adjust 1 MHz RES BW. Lin to Log LC2.
RBW 1M	
ERR 483	Unable to adjust 10 kHz RES BW. Lin to Log XTAL1.
RBW 10K	
ERR 484	Unable to adjust 3 kHz RES BW. Lin to Log XTAL2.
RBW 3K	
ERR 485	Unable to adjust 1 kHz RES BW. Lin to Log XTAL3.
RBW 1K	
ERR 486	Unable to adjust 300 Hz RES BW. Lin to Log XTAL4.
RBW 300	
ERR 487	Unable to adjust 100 Hz RES BW. Lin to Log XTAL5.
RBW 100	
ERR 488	Unable to adjust 100 Hz RES BW.
RBW 100	
ERR 489	Unable to adjust 100 Hz RES BW.
RBW 100	
ERR 490	Unable to adjust 100 Hz RES BW.
RBW 100	
ERR 491	Unable to adjust 100 Hz RES BW. XTAL SWP GAIN.
RBW 100	
ERR 492	Unable to adjust 300 Hz RES BW. XTAL SWP GAIN.
RBW 300	
ERR 493	Unable to adjust 1 kHz RES BW. XTAL SWP GAIN.
RBW 1K	

E-10 Error Messages

ERR 494 RBW 3K	Unable to adjust 3 kHz RES BW. XTAL SWP GAIN.
ERR 495 RBW 10K	Unable to adjust 10 kHz RES BW. XTAL SWP GAIN.
ERR 496 RBW 100	Unable to adjust 100 Hz RES BW. Inadequate Q.
ERR 497 RBW 100	Unable to adjust 100 Hz RES BW. Alignment.
ERR 498 RBW 100	Unable to adjust 100 Hz RES BW. Gain.
ERR 499 CAL UNLK	Cal Oscillator is unlocked.
ERR 500 AMPL 30K	Unable to adjust amplitude of 30 kHz RES BW.
ERR 501 AMPL .1M	Unable to adjust amplitude of 100 kHz RES BW.
ERR 502 AMPL .3M	Unable to adjust amplitude of 300 kHz RES BW.
ERR 503 AMPL 1M	Unable to adjust amplitude of 1 MHz RES BW.
ERR 504 AMPL 30K	Unable to adjust amplitude of 30 kHz RES BW. CAL Gain.
ERR 505 AMPL .1M	Unable to adjust amplitude of 100 kHz RES BW. CAL Gain.
ERR 506 AMPL .3M	Unable to adjust amplitude of 300 kHz RES BW. CAL Gain.
ERR 507 AMPL 1M	Unable to adjust amplitude of 1 MHz RES BW. CAL Gain.
ERR 508 AMPL 30K	Insufficient gain during LC BW Cal of 30 kHz RES BW.
ERR 509 AMPL .1M	Insufficient gain during LC BW Cal of 100 kHz RES BW.
ERR 510 AMPL .3M	Insufficient gain during LC BW Cal of 300 kHz RES BW.
ERR 511 AMPL 1M	Insufficient gain during LC BW Cal of 1 MHz RES BW.
ERR 512 RBW 100	Insufficient gain during crystal BW Cal of 100 Hz RES BW.
ERR 513 RBW 300	Insufficient gain during crystal BW Cal of 300 Hz RES BW.
ERR 514 RBW 1K	Insufficient gain during crystal BW Cal of 1 kHz RES BW.
ERR 515 RBW 3K	Insufficient gain during crystal BW Cal of 3 kHz RES BW.

ERR 516 Insufficient gain during crystal BW Cal of 10 kHz RES BW.
RBW 10K

ERR 517 Unable to adjust 100 Hz RES BW. XTAL SWP PROB.
RBW 100

ERR 518 Unable to adjust 300 Hz RES BW. XTAL SWP PROB.
RBW 300

ERR 519 Unable to adjust 1 kHz RES BW. XTAL SWP PROB.
RBW 1K

ERR 520 Unable to adjust 3 kHz RES BW. XTAL SWP PROB.
RBW 3K

ERR 521 Unable to adjust 10 kHz RES BW. XTAL SWP PROB.
RBW 10K

ERR 522 Unable to adjust 10 kHz RES BW. SYM POLE 1.
RBW 10K

ERR 523 Unable to adjust 10 kHz RES BW. SYM POLE 2.
RBW 10K

ERR 524 Unable to adjust 10 kHz RES BW. SYM POLE 3.
RBW 10K

ERR 525 Unable to adjust 10 kHz RES BW. SYM POLE 4.
RBW 10K

ERR 526 Unable to adjust <300 Hz RES BWs. Timeout during data sampling.
RBW <300

ERR 527 Step gain correction failed for <300 Hz RES BW. Narrow BW SGO 9dB attn
RBW <300 failed.

ERR 528 Unable to adjust <300 Hz RES BWs. DC level at ADC cannot be calibrated.
RBW <300

ERR 529 Unable to adjust <300 Hz RES BWs. Demod data for calibration is bad.
RBW <300

ERR 530 Unable to adjust <300 Hz RES BWs. Narrow BW VCXO Calibration failed
RBW <300

ERR 531 Flatness correction data not acceptable for <300 Hz RES BWs.
RBW <300

ERR 532 Absolute gain data for <300 Hz RES BWs not acceptable.
RBW <300

ERR 533 Unable to adjust <300 Hz RES BWs. Timeout during data sampling narrow
RBW <300 BW chunk.

ERR 534 Unable to adjust <300 Hz RES BWs. Frequency count of CAL OSC using IF
RBW <300 downconverter failed.

ERR 535 Unable to adjust <300 Hz RES BWs. Inadequet FM demod range for 500Hz
RBW <300 IF filter measurement.

ERR 536 Unable to adjust <300 Hz RES BWs. Unable to autorange the chirp signal.
RBW <300

ERR 537 Unable to adjust <300 Hz RES BWs. CW CAL OSC not autoranging.
RBW <300

E-12 Error Messages

ERR 538 Unable to adjust <300 Hz RES BWs. Noisy shape of 500 Hz IF filter.
RBW <300

ERR 539 Unable to adjust <300 Hz RES BWs. CW CAL OSC not autoranging.
RBW <300

ERR 540 Unable to adjust <300 Hz RES BWs. No SIGLOCK on CW CAL OSC
RBW <300 during pretune.

ERR 550 CAL Oscillator ID. Indicates incompatible hardware. Cal Osc not expected
IDCALOSC

ERR 551 LOG Board ID. Indicates incompatible hardware. Log board not expected.
ID LOGBD

ERR 553 Unable to adjust amplitude of log scale. Divide by 0_D in CalLogGain.
LOG AMPL

ERR 554 Unable to adjust amplitude of log scale. Divide by 0_M in CalLogGain.
LOG AMPL

ERR 555 Unable to adjust amplitude in log scale. No TOS_G in CalLogGain.
LOG AMPL

ERR 556 Unable to adjust amplitude in log scale. No TOS_O in CalLogGain.
LOG AMPL

ERR 557 Unable to adjust amplitude in log scale. Insufficient IF gain in CalLogGain.
LOG AMPL

ERR 558 Unable to adjust amplitude in log scale. Negative M,0 in CalLogGain.
LOG AMPL

ERR 559 Unable to adjust amplitude in log scale. Low MDAC value.
LOG AMPL

ERR 560 Unable to adjust amplitude in log scale. High MDAC value.
LOG AMPL

ERR 561 Unable to adjust amplitude in log scale. Second Step Gain/P1 offset in
LOG AMPL CalLogGain.

ERR 562 Unable to adjust amplitude in log scale. Second Step Gain/P2 offset in
LOG AMPL CalLogGain.

ERR 563 Unable to adjust amplitude in log scale. Third Step Gain range problem in
LOG AMPL CalLogPower.

ERR 564 Unable to adjust amplitude in log scale. No Compression in CalLogPower
LOG AMPL

ERR 565 Unable to adjust amplitude in log scale. Gain Compression Error in
LOG AMPL CalLogPower.

ERR 566 Unable to adjust amplitude in log scale. Unable to set LOG CAL LVL in
LOG AMPL CalLogPower.

ERR 567 Unable to adjust amplitude in log scale. No TOS LX in CalLogExpand.
LOG AMPL

ERR 568 Unable to adjust amplitude in log scale. No LVL LX in CalLogPower.
LOG AMPL

ERR 569 LOG AMPL	Unable to adjust amplitude in log scale. Low MDACX value in CalLogExpand.
ERR 570 LOG AMPL	Unable to adjust amplitude in log scale. High MDACX value in CalLogExpand.
ERR 571 AMPL	Unable to adjust step gain amplifiers. No TOS_D in CalDetectors.
ERR 572 AMPL 1M	Unable to adjust amplitude of 1 MHz RES BW. No TOS_W in CalWidebandLog.
ERR 573 LOG AMPL	Unable to adjust amplitude in log scale. Video offset error + 0.
ERR 574 LOG AMPL	Unable to adjust amplitude in log scale. Video offset error +1.
ERR 575 LOG AMPL	Unable to adjust amplitude in log scale. Video offset error +2.
ERR 576 LOG AMPL	Unable to adjust amplitude in log scale. Video offset error +3.
ERR 577 LOG AMPL	Unable to adjust amplitude in log scale. Video offset error +4.
ERR 578 LOG AMPL	Lim Calibration error from DC Logger Cal
ERR 579 LOG AMPL	Attenuator CAL level error from DC Logger Cal.
ERR 580 LOG AMPL	FID CAL level error from DC Logger Cal
ERR 581 AMPL	Unable to adjust 100 kHz and ≤ 10 kHz RES BWs. ADC/CALOSC handshake CAL in Sweep Xtal.
ERR 582 AMPL	Unable to adjust 100 kHz and ≤ 10 kHz RES BWs. Bad CALOSC Calibration in Sweep Rate.
ERR 583 RBW 30K	Unable to adjust 30 kHz RES BW. SYSBW and LCBW disagreement in LCCAL.
ERR 584 RBW 100K	Unable to adjust 100 kHz RES BW. SYSBW and LCBW disagreement in LCCAL.
ERR 585 RBW 300K	Unable to adjust 300 kHz RES BW. SYSBW and LCBW disagreement in LCCAL.
ERR 586 RBW 1M	Unable to adjust 1 MHz RES BW. SYSBW and LCBW disagreement in LCCAL.
ERR 587 RBW 30K	Unable to adjust 30 kHz RES BW. SYSBW and LCBW disagreement in LCCAL.
ERR 588 RBW 100K	Unable to adjust 100 kHz RES BW. SYSBW and LCBW disagreement in LCCAL.
ERR 589 RBW 300K	Unable to adjust 300 kHz RES BW. SYSBW and LCBW disagreement in LCCAL.

ERR 590 Unable to adjust 1 MHz RES BW. SYSBW and LCBW disagreement in
RBW 1M LCCAL.

ERR 591 Unable to adjust amplitude in log scale. No power sweep in find compression
LOG AMPL point.

ERR 592 Unable to adjust amplitude in log scale. No compression BOW in find
LOG AMPL compression point.

ERR 593 LIMIT Cal tune error from DC Logger Calibration.
LOG TUNE

ERR 594 Attenuator Calibration Offset error from DC Logger Calibration.
LOG OFST

ERR 595 Attenuator Calibration Absolute error from DC Logger Calibration.
LOG ATTN

ERR 596 Fidelity error from DC Logger Calibration.
LOG FID

ERR 597 Fidelity Offset error from DC Logger Calibration.
LOG OFST

ERR 598 Fidelity Offset unstable from DC Logger calibration.
LOG OFST

ERR 599 Fidelity Gain error from DC Logger calibration.
LOG GAIN

Error codes 600 through 699 relate to system failures. Instrument service is required.

ERR 600 Hardware/firmware interaction; check other errors.
SYSTEM

ERR 601 Hardware/firmware interaction; check other errors.
SYSTEM

ERR 650 ADC input is outside of the ADC range.
OUTOF RG

ERR 651 Microprocessor is not receiving interrupt from ADC.
NO IRQ

Error codes 700 through 799 relate to digital and checksum failures. Instrument service is required.

ERR 700 Checksum error of EEROM A2U501
EEROM

ERR 701 Checksum error of frequency response correction data.
AMPL CAL

ERR 702 Checksum error of elapsed time data.
ELAP TIM

ERR 703 Checksum error of frequency response correction data.
AMPL CAL

ERR 704 Checksum error of customer preselector peak data; external preselector data
PRESELCT recalled in internal mode; or internal preselector data recalled in external
mode.

ERR 705 ROM U306	Checksum error of program ROM A2U306.
ERR 706 ROM U307	Checksum error of program ROM A2U307.
ERR 707 ROM U308	Checksum error of program ROM A2U308.
ERR 708 ROM U309	Checksum error of program ROM A2U309.
ERR 709 ROM U310	Checksum error of program ROM A2U310.
ERR 710 ROM U311	Checksum error of program ROM A2U311.
ERR 711 RAM U303	Checksum error of system RAM A2U303.
ERR 712 RAM U302	Checksum error of system RAM A2U302.
ERR 713 RAM U301	Checksum error of system RAM A2U301.
ERR 714 RAM U300	Checksum error of system RAM A2U300.
ERR 715 RAM U305	Checksum error of system RAM A2U305.
ERR 716 RAM U304	Checksum error of system RAM A2U304.
ERR 717 BAD uP!!	Microprocessor not fully operational.
ERR 718 BATTERY?	Nonvolatile RAM not working; check battery.
ERR 750 SYSTEM	Hardware/firmware interaction, zero divide; check other errors.
ERR 751 SYSTEM	Hardware/firmware interaction, floating overflow; check other errors.
ERR 752 SYSTEM	Hardware/firmware interaction, floating underflow; check other errors.
ERR 753 SYSTEM	Hardware/firmware interaction, LOG error; check other errors.
ERR 754 SYSTEM	Hardware/firmware interaction, Integer overflow; check other errors.
ERR 755 SYSTEM	Hardware/firmware interaction, squareroot error; check other errors.
ERR 756 SYSTEM	Hardware/firmware interaction, Triple underflow; check other errors.
ERR 757 SYSTEM	Hardware/firmware interaction, BCDL overflow; check other errors.

ERR 759 Hardware/firmware interaction, Code invoked for wrong instrument.
SYSTEM

ERR 755 Hardware/firmware interaction, squareroot error; check other errors.
SYSTEM

Note



Error codes 800 through 899, MODULE, are reserved for option modules, such as the HP 85629B Test and Adjustment Module or the HP 85620A Mass Memory Module. Refer to the option module's manual for a list of product-specific error messages.

Error codes 900 to 904, relate to user-generated errors.

These errors occur if the operator has entered information incorrectly, or is attempting to use the analyzer inappropriately.

ERR 900 Tracking generator output is unleveled.
TG UNLVL

ERR 901 Tracking generator output unleveled because START FREQ is set below
TGFrqLmt tracking generator frequency limit (300 kHz).

ERR 902 The state of the stored trace does not match the current state of the analyzer.
BAD NORM

ERR 903 Unnormalized trace A is off screen with trace math or normalization on.
A > DLMT

ERR 904 Calibration trace (trace B) is off screen with trace math or normalization on.
B > DLMT

ERR 905 Unable to lock Cal Oscillator when set to external reference. Check that
EXT REF external reference is within tolerance.

ERR 906 The OCXO oven is cold.
OVENCOLD

ERR 907 Unit is still performing IF calibration or is in need of IF calibration which
DO IF CALS were not done due to an OVENCOLD condition.

ERROR 908 Channel bandwidth is too wide, compared to the channel spacing, for a
BW>>SPCG significant computation.

ERROR 909 The frequency span is too small to obtain a valid measurement.
SPAN<ACP

ERROR 910 The frequency span is too wide, compared to the channel bandwidth, to
SPAN>ACP obtain a valid measurement.



Backward-Compatible Commands

The following list of commands are used by the HP 8566A and HP 8568A spectrum analyzers and are recognized by the HP 8560A, HP 8561B, and HP 8563A. This allows the HP 8560A, HP 8561B, and HP 8563A to use programs written for these Hewlett-Packard spectrum analyzers with only minor modifications. It is recommended that only the HP 8560A, HP 8561B, and HP 8563A commands be used when writing new programs.

Backward-Compatible Commands

Old Command	HP 8560A, HP 8561B, and HP 8563A Command	Description
A1	CLRW TRA	Clear-Write Trace A
A2	MXMH TRA	Maximum Hold Trace A
A3	VIEW TRA	Store-View Trace A
A4	BLANK TRA	Blank Trace A
B1	CLRW TRB	Clear-Write Trace B
B2	MXMH TRB	Maximum Hold Trace B
B3	VIEW TRB	Store-View Trace B
B4	BLANK TRB	Blank Trace B
BL	BML	Trace B minus Display Line
C1	AMB OFF	Trace A minus Trace B off
C2	AMB ON	Trace A minus Trace B on
CA	AT AUTO	Couples the RF attenuator
CR	RB AUTO	Couples the resolution bandwidth
CS	SS AUTO	Couples the center frequency step size
CT	ST AUTO	Couples the sweep time
CV	VB AUTO	Couples the video bandwidth
E1	MKPK HI	Marker to highest peak
E2	MKCF	Marker to Center Frequency
E3	MKSS	Marker Frequency to Center Frequency Step Size
E4	MKRL	Marker to Reference Level

Backward-Compatible Commands (continued)

Old Command	HP 8560A, HP 8561B, and HP 8563A Command	Description
EX	AXB	Exchange Trace A and Trace B
GZ	GHZ	Gigahertz (unit)
KZ	KHZ	Kilohertz (unit)
L0	DL OFF	Display Line off
LB	TEXT	Write text to display
M1	MKOFF	Marker off
M2	MKN	Marker Normal on
M3	MKD	Marker Delta on
MA	MKA?	Query Marker Amplitude
MF	MKF?	Query Marker Frequency
MZ	MHZ	Megahertz (unit)
MT0	MKTRACK OFF	Marker Track off
MT1	MKTRACK ON	Marker Track on
PRSDAC	PSDAC	Query Preselector DAC number
RC	RCLS	Recall Instrument State
S1	CONTS	Continuous Sweep
S2	SNGLS	Single Sweep
SV	SAVES	Save Instrument State
T1	TM	Trigger Mode Free Run
T2	TM LIN	Trigger Mode Line
T3	TM EXT	Trigger Mode External
T4	TM VID	Trigger Mode Video
TA	TRA?	Trace A Data
TB	TRB?	Trace B Data

Backward-Compatible Commands

The following list of commands are used by the HP 8566A and HP 8568A spectrum analyzers and are recognized by the HP 8560A, HP 8561B, and HP 8563A. This allows the HP 8560A, HP 8561B, and HP 8563A to use programs written for these Hewlett-Packard spectrum analyzers with only minor modifications. It is recommended that only the HP 8560A, HP 8561B, and HP 8563A commands be used when writing new programs.

Backward-Compatible Commands

Old Command	HP 8560A, HP 8561B, and HP 8563A Command	Description
A1	CLRW TRA	Clear-Write Trace A
A2	MXMH TRA	Maximum Hold Trace A
A3	VIEW TRA	Store-View Trace A
A4	BLANK TRA	Blank Trace A
B1	CLRW TRB	Clear-Write Trace B
B2	MXMH TRB	Maximum Hold Trace B
B3	VIEW TRB	Store-View Trace B
B4	BLANK TRB	Blank Trace B
BL	BML	Trace B minus Display Line
C1	AMB OFF	Trace A minus Trace B off
C2	AMB ON	Trace A minus Trace B on
CA	AT AUTO	Couples the RF attenuator
CR	RB AUTO	Couples the resolution bandwidth
CS	SS AUTO	Couples the center frequency step size
CT	ST AUTO	Couples the sweep time
CV	VB AUTO	Couples the video bandwidth
E1	MKPK HI	Marker to highest peak
E2	MKCF	Marker to Center Frequency
E3	MKSS	Marker Frequency to Center Frequency Step Size
E4	MKRL	Marker to Reference Level

Backward-Compatible Commands (continued)

Old Command	HP 8560A, HP 8561B, and HP 8563A Command	Description
EX	AXB	Exchange Trace A and Trace B
GZ	GHZ	Gigahertz (unit)
KZ	KHZ	Kilohertz (unit)
L0	DL OFF	Display Line off
LB	TEXT	Write text to display
M1	MKOFF	Marker off
M2	MKN	Marker Normal on
M3	MKD	Marker Delta on
MA	MKA?	Query Marker Amplitude
MF	MKF?	Query Marker Frequency
MZ	MHZ	Megahertz (unit)
MT0	MKTRACK OFF	Marker Track off
MT1	MKTRACK ON	Marker Track on
PRSDAC	PSDAC	Query Preselector DAC number
RC	RCLS	Recall Instrument State
S1	CONTS	Continuous Sweep
S2	SNGLS	Single Sweep
SV	SAVES	Save Instrument State
T1	TM	Trigger Mode Free Run
T2	TM LIN	Trigger Mode Line
T3	TM EXT	Trigger Mode External
T4	TM VID	Trigger Mode Video
TA	TRA?	Trace A Data
TB	TRB?	Trace B Data

Resolution Bandwidth

Signal resolution is determined by the intermediate frequency (IF) filter bandwidth. The spectrum analyzer traces the shape of its IF filter as it tunes past a signal. Thus, if two equal-amplitude signals are close enough in frequency, the filter shapes can fall on top of one another and appear as a single response. If two signals are not equal in amplitude but are still close together, the smaller signal can be hidden under the response of the larger one.

The resolution bandwidth function (RES BW) selects the appropriate IF bandwidth for a measurement. (Hewlett-Packard specifies resolution bandwidth as the 3 dB bandwidth of a filter.) The following guidelines can help you determine the appropriate resolution bandwidth to choose.

Input Signals of Equal Amplitude

Generally, to resolve two signals of equal amplitude, the resolution bandwidth must be less than or equal to the frequency separation of the two signals. For example, to resolve two signals of equal amplitude with a frequency separation of 1 kHz, a resolution bandwidth of 1 kHz or less should be used (see Figure G-1). Further, to resolve two signals with a frequency separation of 2 kHz, a 1 kHz resolution bandwidth again must be used (see Figure G-2). Since the spectrum analyzer uses bandwidths in a 1, 3, 10 sequence, the next larger filter, 3 kHz, would exceed the 2 kHz separation and thus would not resolve the signals.

Keep in mind that phase noise can also affect resolution.

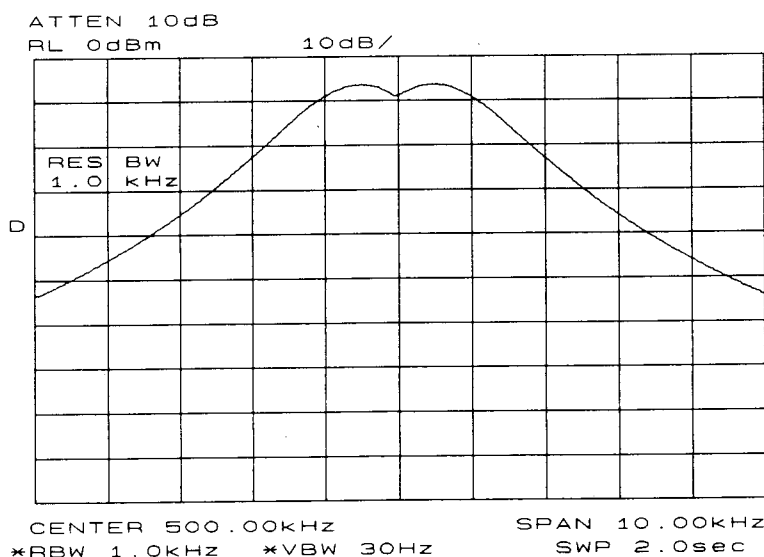

Figure G-1. 1 kHz Signal Separation

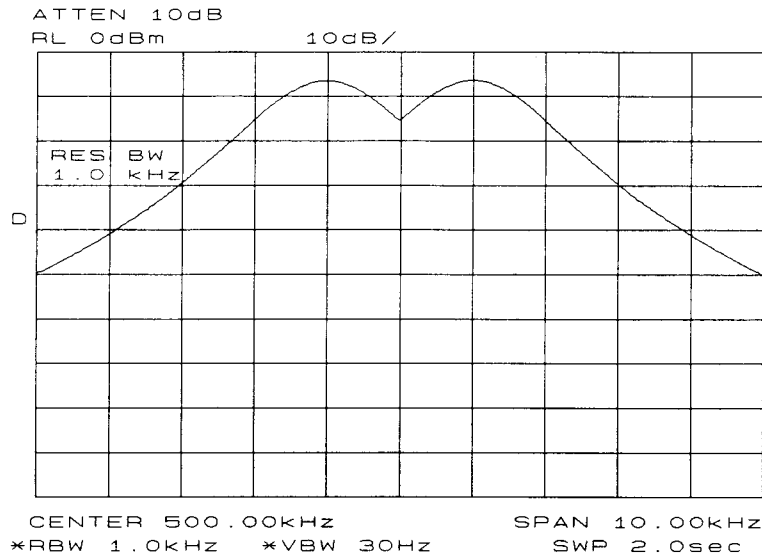

Figure G-2. 2 kHz Signal Separation

Input Signals of Unequal Amplitude

To resolve two signals of unequal amplitude, the resolution bandwidth must also be less than or equal to the frequency separation of the two signals. However, in this case the largest resolution bandwidth that will resolve the two unequal signals is determined primarily by the shape factor of the IF filter, rather than by the 3 dB bandwidth. (Shape factor is defined as the ratio of the 3 dB bandwidth to the 60 dB bandwidth of the IF filter, as in Figure G-3. The IF filters in this spectrum analyzer have shape factors of 15:1 or better.) Therefore, to resolve two signals of unequal amplitude, the half-bandwidth of a filter at the point equal to the amplitude separation of the two signals must be less than the frequency separation of the two signals.

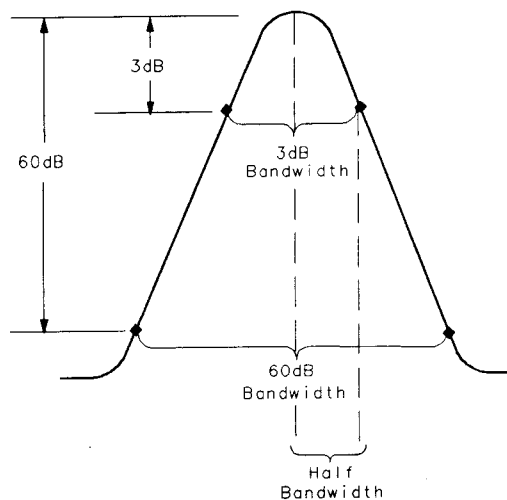

Figure G-3. Bandwidth Shape Factor

For example, consider resolving a third-order intermodulation distortion product with a frequency separation of 700 kHz and an amplitude separation of 60 dB. Using a 100 kHz filter with a typical shape factor of 12:1, the filter will have a 60 dB bandwidth of 1.2 MHz and a half-bandwidth value of 600 kHz. This half-bandwidth is narrower than the frequency separation, so the two input signals will be resolved (see Figure G-4). However, using a 300 kHz filter, the 60 dB bandwidth is 3.6 MHz and the half-bandwidth value is 1.8 MHz. Since this half-bandwidth is wider than the frequency separation, the signals most likely would not be resolved (see Figure G-5).

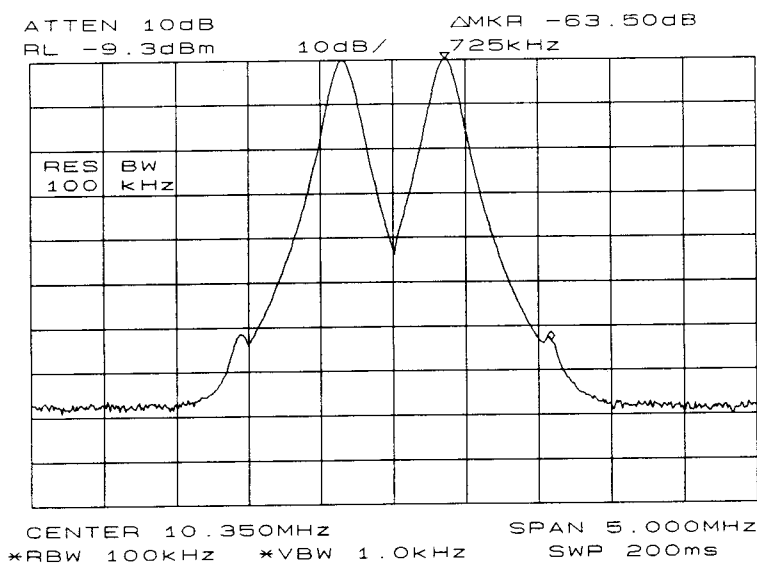

Figure G-4. 100 kHz Bandwidth Resolution

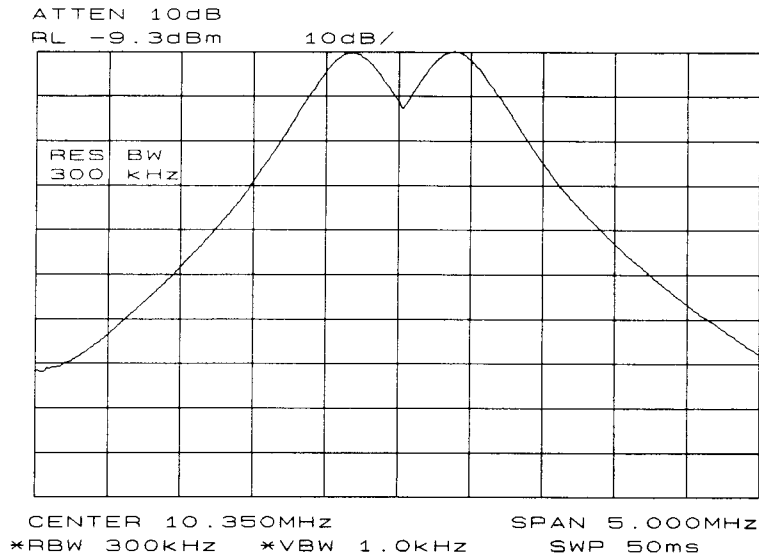

Figure G-5. 300 kHz Bandwidth Resolution

Note



Spectrum analyzer sweep time is inversely proportional to the square of the resolution bandwidth. So, if the resolution bandwidth is reduced by a factor of ten, the sweep time is increased by a factor of 100. For fastest measurement times, use the widest resolution bandwidth that still permits resolution of all desired signals.

Modulation

Amplitude Modulation

Figure H-1 illustrates an amplitude-modulated signal as seen on a spectrum analyzer display. Note the carrier signal. To determine its frequency, simply press **PEAK SEARCH**. Additional modulation information can be easily determined from the carrier signal and a sideband. For example, the difference between the carrier frequency and the sideband frequency can be found by pressing **PEAK SEARCH**, **MARKER DELTA**, and **NEXT PEAK**. The markers read the frequency difference between the two signals, which is equal to the modulating frequency. The marker also reads the difference in amplitude. This difference in amplitude between the two signals can be used to determine percentage of modulation (refer to Figure H-2).

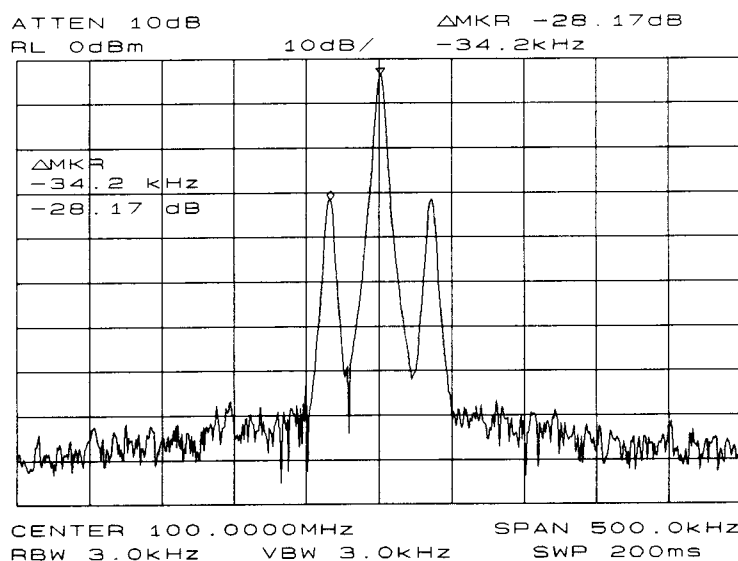

Figure H-1. An Amplitude-Modulated Signal

Note



Unequal amplitudes of the lower and upper sidebands indicate incidental FM on the input signal. Incidental FM can reduce the accuracy of percentage-of-modulation measurements.

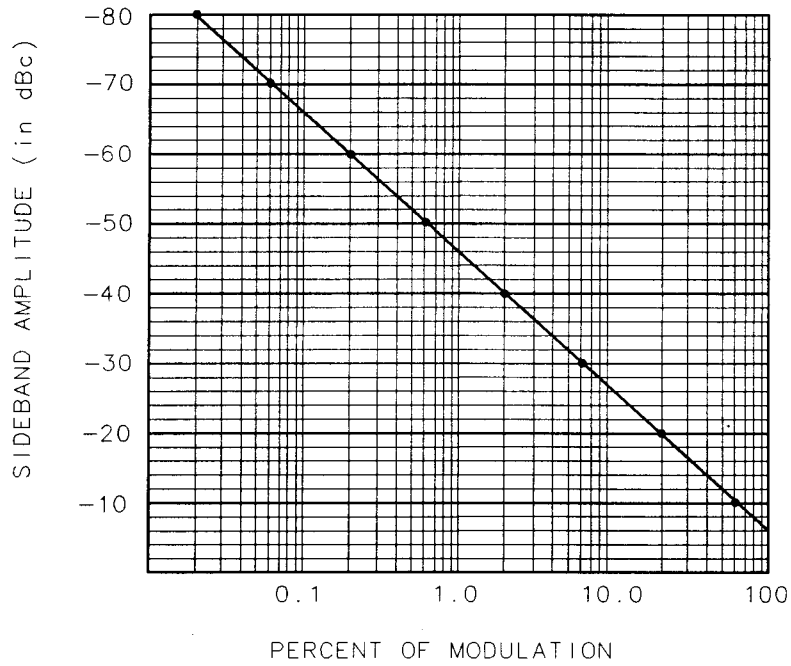

Figure H-2. Percentage of Modulation

The following equation also determines percentage of modulation using amplitude units in volts:

$$M = \frac{2A_s \times 100}{A_c}$$

where A_s = sideband amplitude, in volts

A_c = carrier amplitude, in volts

Frequency Modulation

This section contains general information about frequency modulation, as well as a procedure for calculating FM deviation using a spectrum analyzer.

Figures H-3, H-4, and H-5 illustrate a frequency-modulated signal as it appears on a spectrum analyzer. Figure H-6 contains Bessel functions for determining modulation. (Tables H-1 and H-2 also contain modulation index numbers for carrier nulls and first sideband nulls.)

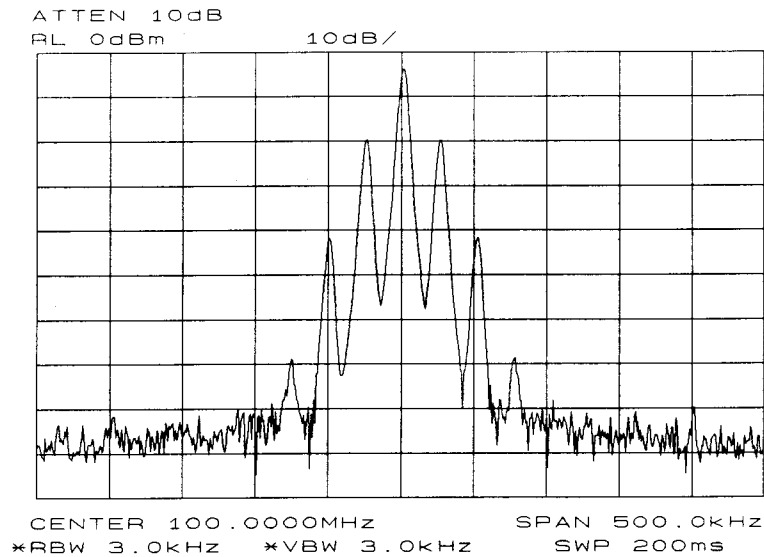

Figure H-3. A Frequency-Modulated Signal

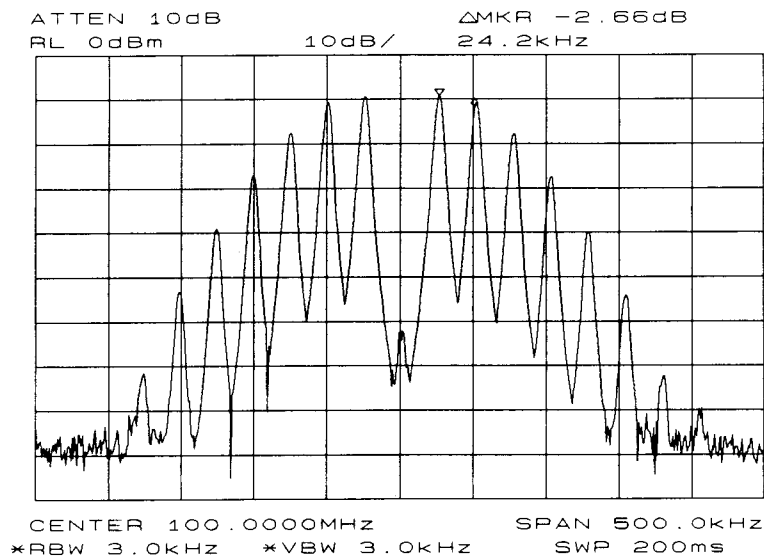

Figure H-4. FM Signal with Carrier at a Null

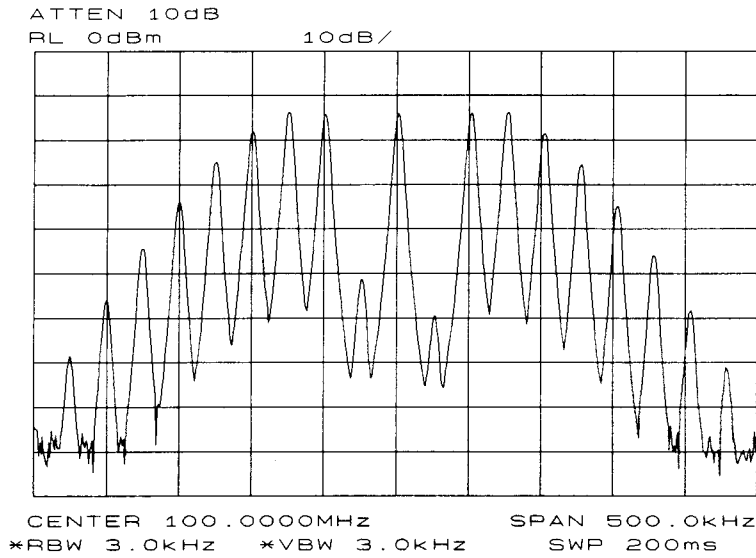

Figure H-5. FM Signal with First Sidebands at a Null

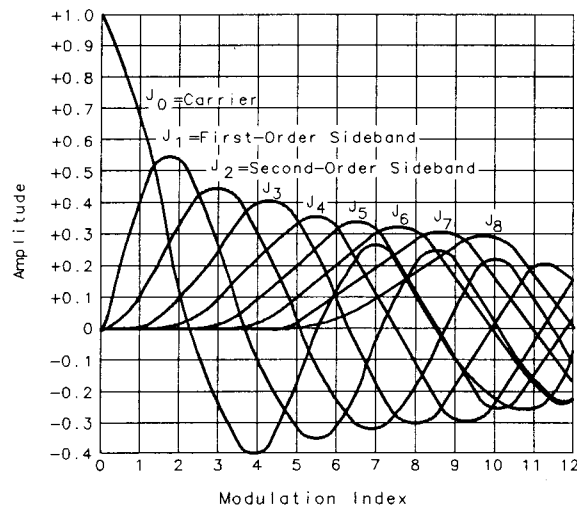

Figure H-6. Bessel Functions for Determining Modulation Index

Table H-1. Carrier Nulls and Modulation Indexes

Order of Carrier Null	Modulation Index
1	2.401
2	5.520
3	8.653
4	11.791
5	14.931
6	18.071
$n (n > 6)$	$18.071 + \pi(n - 6)$

Table H-2. Sideband Nulls and Modulation Indexes

Order of First Sideband Null	Modulation Index
1	3.83
2	7.02
3	10.17
4	13.32
5	16.47
6	19.62

For sinusoidal modulation where either the modulation frequency or the FM deviation can be varied, the spectrum analyzer can be used to accurately set up a modulation index corresponding to a Bessel null. The following example illustrates how to verify the FM deviation accuracy of a signal generator with FM capability. We will use a carrier frequency of 100 MHz and test for FM deviation accuracy at a 25 kHz rate using the modulation index for the first carrier null (2.401). Figure H-7 illustrates how to set up the equipment for this measurement.

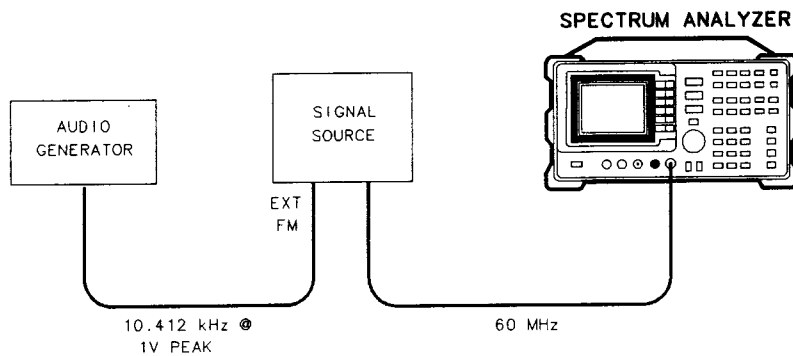

Figure H-7. FM Deviation Test Setup

Beginning with the spectrum analyzer in a preset state, connect the source to the spectrum analyzer input. Set the source to 100 MHz. Set the center frequency of the spectrum analyzer to 100 MHz and the span to 100 kHz. Knowing that the desired deviation is 25 kHz, and choosing the modulation index of the first carrier null, calculate the modulating frequency as follows:

$$\text{Modulating Frequency} = \frac{25 \text{ kHz}}{2.401}$$

$$\text{Modulating Frequency} = 10.412 \text{ kHz}$$

Set the modulation rate on the signal generator to 10.412 kHz. If the signal generator doesn't have an accurate internal audio source, use an external audio source. You can use the delta count mode of the analyzer to accurately set the audio source frequency as follows: press **FREQ COUNT** to activate the counter function, then press **COUNTER RES** and set the counter resolution. Press **COUNTER ON** and use the delta count mode to read the difference between two sideband peaks (see Figure H-8). Now adjust the frequency deviation for a maximum null of the carrier. Calculate the FM deviation by multiplying the modulation index (from Table H-1) by the modulation rate:

Pulsed RF

This section contains information on pulsed RF and illustrates several procedures for measuring characteristics of a pulsed-RF signal. The procedures explain how to measure center frequency, pulse width, and pulse repetition frequency.

Pulse Mode

Pulsed RF measurements are generally made in the “pulse” mode. To set the spectrum analyzer for pulse-mode measurements, begin by setting the video bandwidth to 3 MHz and activate the positive peak detector (press **TRACE**, **MORE**, **DETECTOR MODES**, and **DETECTOR POS PEAK**). Select the center frequency, then adjust the span until the center lobe and at least one pair of side lobes appear on the display (see Figure I-1). Increase the sweep time (that is, the sweep becomes slower) until the display fills in and becomes a solid line (see Figure I-2). If this line does not fill in, the instrument is not in pulse mode, in which case the following procedures for side lobe ratio, pulse width, and peak pulse power do not apply. For further reference, consult Hewlett-Packard Application Note 150-2, entitled “Pulsed RF.”

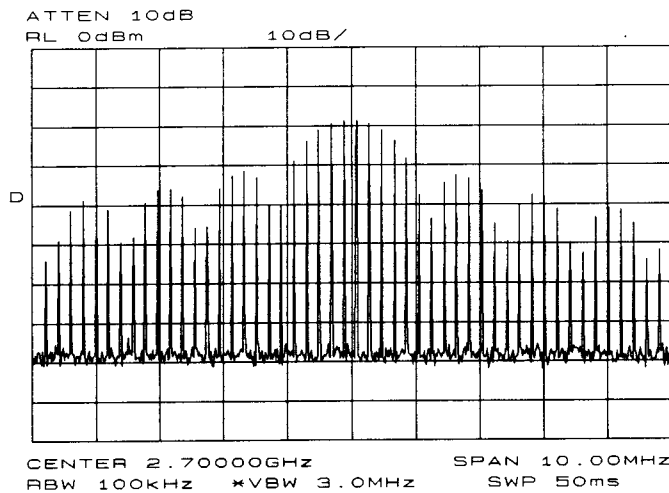

Figure I-1. Main Lobe and Side Lobes

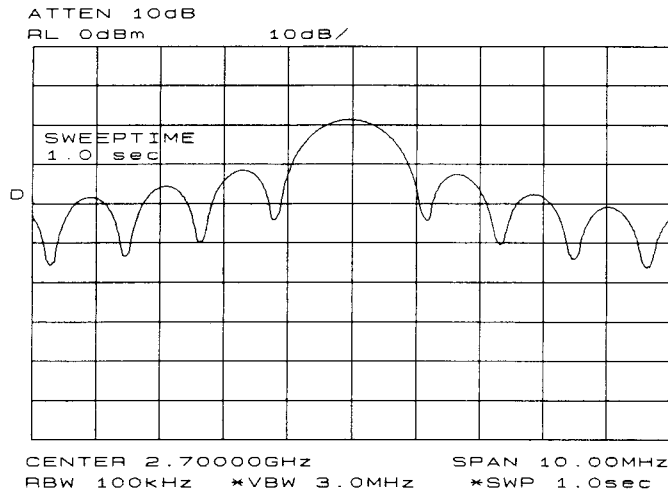

Figure I-2. Trace Displayed as a Solid Line

Center Frequency, Sidelobe Ratio, and Pulse Width

For a pulsed RF signal, the center frequency is at the center of the main lobe (see Figure I-3). To identify this frequency, simply use the spectrum analyzer peak search function. The marker also reads the main lobe amplitude.

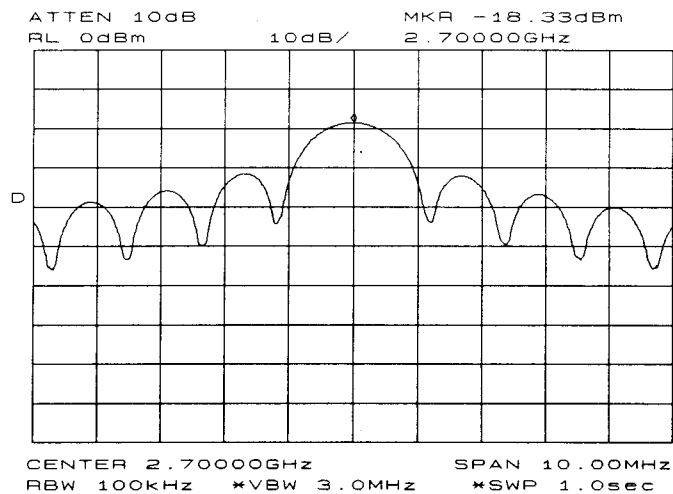

Figure I-3. Center Frequency at Center of Main Lobe

To measure the side lobe ratio, with the marker still at the center frequency of the main lobe, press the **MARKER DELTA** and **NEXT PEAK** (see Figure I-4). The difference between the amplitude of the main lobe and the side lobe is the side lobe ratio.

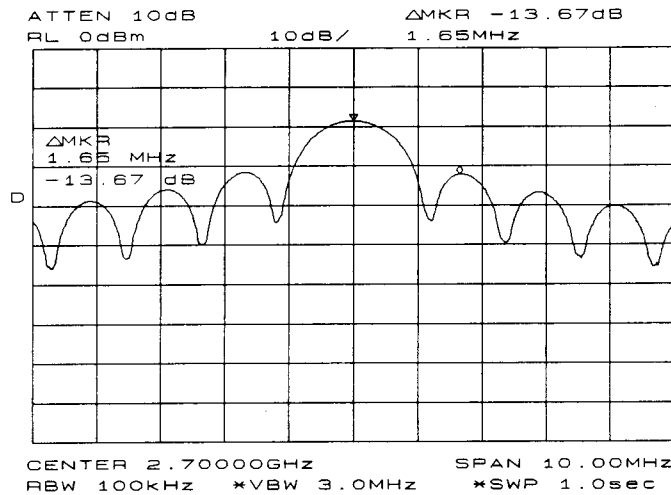

Figure I-4. Markers Show Sidelobe Ratio

The pulse width is also easy to identify. The pulse width is the reciprocal of the frequency difference between two envelope peaks. To determine this difference, continuing from the last procedure, press **MARKER DELTA**, **MORE**, and **NEXT PK RIGHT**; then press **ON**, and **MARKER 1/DELTA**. The pulse width is equal to the time value displayed on the spectrum analyzer screen, as in Figure I-5. For best pulse-width accuracy, measure the distance between two adjacent lobe nulls by manually adjusting the marker positions. If desired, first reduce the resolution bandwidth for sharper nulls.

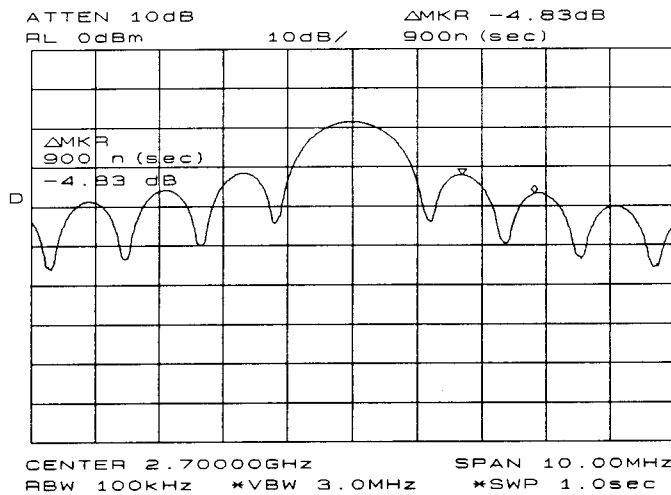

Figure I-5. Markers Show Pulse Width

Pulse Repetition Frequency (PRF)

Pulse repetition interval (PRI) is the spacing in time between any two adjacent pulse responses, shown in Figure I-1. Using the **MARKER 1/DELTA** function, PRI can easily be inverted to read PRF instead. To measure PRI, set the span to 0 Hz and adjust amplitude of the main lobe to the reference level. Set the amplitude scale to linear and readjust the signal so that it is on screen. Next, decrease the sweep time (that is, the sweep becomes faster) until the display resembles Figure I-6. Select the **SINGLE** trigger mode. Finally, press **PEAK SEARCH**, **MARKER DELTA**, **MORE**, and **NEXT PK RIGHT** or **NEXT PK LEFT**. The difference displayed between the two markers is equal to the PRI. Simply press **ON** and **MARKER 1/DELTA** for the PRF, as shown in Figure I-6.

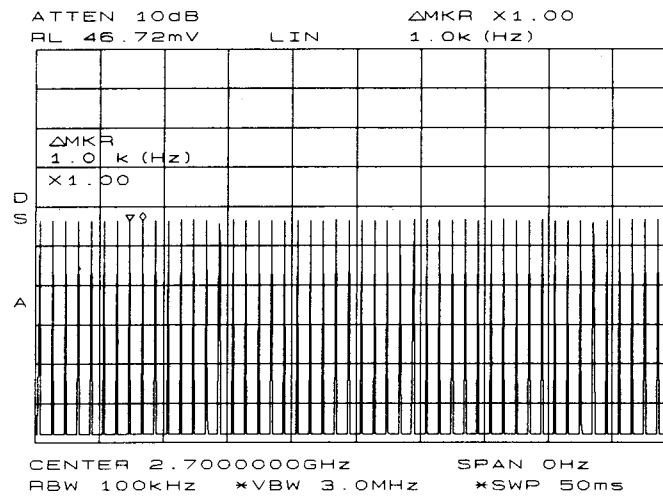

Figure I-6. Measuring Pulse Repetition Frequency

Peak Pulse Power and Desensitization

Now that you know the main lobe amplitude, the pulse width, and can easily note the spectrum analyzer resolution bandwidth, the peak pulse power can be derived from a relatively simple equation:

$$\text{Peak Pulse Power} = (\text{Mainlobe Amplitude}) - (20 \log T_{\text{eff}})(BW_i)$$

where T_{eff} = pulse width, in seconds

BW_i = impulse bandwidth, in Hertz

$BW_i = 1.5 \times$ resolution bandwidth used
to measure pulse width.

Note

While measuring the main lobe amplitude, change the spectrum analyzer attenuation and check that the main lobe amplitude does not change. If it changes by more than 1 dB, the analyzer is in compression and the RF attenuation must be increased. For carrier frequencies above 2.7 GHz, be sure to peak the preselector to measure the main lobe amplitude accurately.

The difference between the peak pulse power and the main lobe amplitude is called pulse desensitization. The term “pulse desensitization” can be somewhat misleading, because pulsed signals do not reduce spectrum analyzer sensitivity. Rather, apparent desensitization occurs because the power of a pulsed continuous wave (CW) carrier is distributed over a number of spectral components (that is, the carrier and sidebands). As a result, each spectral component contains only a fraction of the total power. For a complete discussion of pulse desensitization, refer to Application Note 150-2 (literature number 5952-1039) or Appendix A of Application Note 330-1 (literature number 5954-2705).



Index

0

0 -> 10V LO SWP softkey, 2-41

1

10 MHz EXT INT softkey, 2-41
12.5kHz/8.5kHz softkey, 2-57

2

20.0kHz/14.0kHz softkey, 2-57
25.0kHz/16.0kHz softkey, 2-57

3

3 dB POINTS softkey, 2-52

5

.5 V/GHz (FAV) softkey, 2-41

6

6 dB POINTS softkey, 2-52

A

A-B->A ON OFF softkey, 2-81
A+B->A softkey, 2-81
A-B+DL->A ON OFF softkey, 2-81
absolute amplitude units, 5-35
ac coupling, 2-10
ACPBW command, 5-15
ACPCOMPUTE command, 5-16
ACP COMPUTE softkey, 2-55
ACPGRAPH command, 5-17
ACPGRAPH ON OFF softkey, 2-56
ACPLOWER command, 5-18
ACPMAX command, 5-19
ACPMEAS command, 5-20
ACP MENU softkey, 2-52
ACPPWRTX command, 5-21
ACPSP command, 5-22
ACPUPPER command, 5-23
active function area, 1-5
active special functions, 1-5, 2-84
adjacent channel power
 channel bandwidth, 2-57
 channel spacing, 2-57
 compute, 5-16
 lower, 5-18

 maximum, 5-19
 measure, 5-20
 spacing/bandwidth, 2-56
 total power transmitted, 5-21
 upper, 5-23
adjacent channel power computations, 2-59
adjacent channel power instrument setup, 2-58
adjacent channel power measurement, 3-30
adjacent channel power softkeys, 2-52
ADJALL command, 5-24
adjacent channel power
 bandwidth, 5-15
 graph, 5-17
 spacing, 5-22
ADJCRT command, 5-25
ADJ CURR IF STATE softkey, 2-19
ADJIF command, 5-26
adjust CRT alignment, 5-25
A EXCH B softkey, 2-80
AGC ON OFF softkey, 2-41
ALC/EXT input, 1-7
ALC INT EXT softkey, 2-30
alignment of CRT, 5-25
alignment routines, LO and IF, 2-19
ALL softkey, 2-77
AMB command, 5-28
AMBPL command, 5-29
AM DEMOD ON OFF softkey, 2-40
AM/FM DEMOD softkey, 2-39, 3-12
amplitude control functions, 5-8
amplitude correction, 2-33
amplitude functions, 2-9
 UNITS AUTO MAN, 2-10
AMPLITUDE key, 2-7
amplitude modulation, 3-11, H-1
amplitude readout offset, 2-9
amplitude reference offset, 5-150
amplitude scale, 5-88, 5-89
 linear, 2-8
 logarithmic, 2-8
amplitude units, 2-10, 2-78, 5-35
 dBm, 2-10
 dB μ V, 2-10
 dBmV, 2-10
 VOLTS, 2-10
 WATTS, 2-10



Index

0

0 -> 10V LO SWP softkey, 2-41

1

10 MHz EXT INT softkey, 2-41

12.5kHz/8.5kHz softkey, 2-57

2

20.0kHz/14.0kHz softkey, 2-57

25.0kHz/16.0kHz softkey, 2-57

3

3 dB POINTS softkey, 2-52

5

.5 V/GHz (FAV) softkey, 2-41

6

6 dB POINTS softkey, 2-52

A

A-B->A ON OFF softkey, 2-81

A+B->A softkey, 2-81

A-B+DL->A ON OFF softkey, 2-81

absolute amplitude units, 5-35

ac coupling, 2-10

ACPBW command, 5-15

ACPCOMPUTE command, 5-16

ACP COMPUTE softkey, 2-55

ACPGRAPH command, 5-17

ACPGRAPH ON OFF softkey, 2-56

ACPLOWER command, 5-18

ACPMAX command, 5-19

ACPMEAS command, 5-20

ACP MENU softkey, 2-52

ACPPWRTX command, 5-21

ACPSP command, 5-22

ACPUPPER command, 5-23

active function area, 1-5

active special functions, 1-5, 2-84

adjacent channel power

channel bandwidth, 2-57

channel spacing, 2-57

compute, 5-16

lower, 5-18

maximum, 5-19

measure, 5-20

spacing/bandwidth, 2-56

total power transmitted, 5-21

upper, 5-23

adjacent channel power computations, 2-59

adjacent channel power instrument setup, 2-58

adjacent channel power measurement, 3-30

adjacent channel power softkeys, 2-52

ADJALL command, 5-24

adjacent channel power

bandwidth, 5-15

graph, 5-17

spacing, 5-22

ADJCRT command, 5-25

ADJ CURR IF STATE softkey, 2-19

ADJIF command, 5-26

adjust CRT alignment, 5-25

A EXCH B softkey, 2-80

AGC ON OFF softkey, 2-41

ALC/EXT input, 1-7

ALC INT EXT softkey, 2-30

alignment of CRT, 5-25

alignment routines, LO and IF, 2-19

ALL softkey, 2-77

AMB command, 5-28

AMBPL command, 5-29

AM DEMOD ON OFF softkey, 2-40

AM/FM DEMOD softkey, 2-39, 3-12

amplitude control functions, 5-8

amplitude correction, 2-33

amplitude functions, 2-9

UNITS AUTO MAN, 2-10

AMPLITUDE key, 2-7

amplitude modulation, 3-11, H-1

amplitude readout offset, 2-9

amplitude reference offset, 5-150

amplitude scale, 5-88, 5-89

linear, 2-8

logarithmic, 2-8

amplitude units, 2-10, 2-78, 5-35

dBm, 2-10

dB μ V, 2-10

dBmV, 2-10

VOLTS, 2-10

WATTS, 2-10

amplitude values, 5-3
AMPTD CORRECT softkey, 2-33, 3-25
AMPTD UNITS softkey, 2-9, 3-6
ANALYZER ADDRESS softkey, 2-17
analyzer status byte, 4-34
annotation on/off, 5-31
annotation plots, 2-16
ANNOT command, 5-31
ANNOT HELP softkey, 2-84
ANNOT ON OFF softkey, 2-84
APB command, 5-32
Appendix H
 AM/FM modulation, H-1
Appendix I
 Pulsed RF, I-1
AT command, 5-33
ATTEN AUTO MAN softkey, 2-8, 2-77
attenuation, 5-33
AUNITS command, 4-10, 5-35
AUTO ACP MEASURE softkey, 2-52
auto-coupled functions, 5-37
AUTO COUPLE key, 2-77
AUTO CPL command, 5-37
automatic gain control, 2-41, 5-50
AUX CTRL key, 2-22
AVERAGE CNV LOSS softkey, 2-33, 3-25
AXB command, 5-38

B

BACK SPACE softkey, 2-83
bandwidth control functions, 5-8
bandwidth state adjustment, 2-19
basic measurement, 1-10
B-DL->B softkey, 2-81
bias, 3-29
BIAS OFF softkey, 2-38
BIAS softkey, 2-38, 3-29
BLANK A softkey, 2-79
BLANK command, 5-39
blanking output, 1-6
blanking traces, 5-39
BML command, 5-40
built-in tracking generator, 2-26
BW key, 2-74
B & W softkey, 2-15

C

CAL key, 2-19
CAL OPN/SHRT softkey, 2-23, 2-27
CAL THRU softkey, 2-23, 2-27, 3-17
CENTER FREQ softkey, 2-3
center frequency, 1-4, 1-10, 5-41, 5-114
center-frequency step-size, 2-3, 2-78, 5-175
CF command, 5-41
CF STEP AUTO MAN softkey, 2-3, 2-78

CHANNEL BANDWIDTH softkey, 2-57
CHANNEL SPACING softkey, 2-57
character sets, 2-83
CHAR SET 1 2 softkey, 2-83
CLEAR statements, 4-5, 4-6
clear write, 5-43
CLEAR WRITE A softkey, 2-79
CLRW command, 5-43
CNVLOSS command, 5-44
CNV LOSS VS FREQ softkey, 2-33, 3-26
coarse tracking adjust, 5-163
COLOR softkey, 2-15
commands
 backward compatible, F-1
 command sequence, 5-2
 command sequence summary, 5-2
 common measurements
 adjacent channel power measurement, 3-30-33
 AM and FM demodulation, 3-11-12
 external millimeter mixers, 3-23-29
 harmonic distortion, 3-6
 harmonic distortion, 3-1
 stimulus-response, 3-13-22
 third-order intermodulation distortion, 3-7-10
 common measurements, 3-1
 computations of, adjacent channel power, 2-59
 compute adjacent channel power, 5-16
CONFIG key, 2-15
continuous sweep mode, 2-61, 2-73, 2-76, 5-46
control functions, 1-2, 2-72
 auto couple, 2-77
 bandwidth, 2-74
 display, 2-83
 sweep, 2-73
 trace, 2-79
 trigger, 2-76
CONTS command, 5-46
CONT softkey, 2-73, 2-76
conversion loss, 1-5, 2-33, 2-34, 3-25, 5-44
 frequency bands, 2-34
COPY DEV PRNT PLT softkey, 2-15, 3-4
COPY key, 2-43
COUNTER ON OFF softkey, 2-67
COUNTER RES softkey, 2-67
COUPLE command, 5-47
coupled functions, 2-77, 5-37
COUPLING AC DC softkey, 2-10
coupling control functions, 5-8
CRT ADJ PATTERN softkey, 2-20
CRT adjustment
 alignment, 2-20
 TRACE ALIGN, 1-7
 X POSN, 1-7
 Y POSN, 1-7
CRT alignment, 5-25

D

- data byte, 5-3
- data byte & EOI, 5-3
- data entry, 1-2, 1-8
- data invalid indicator, 1-4
- data keys, 1-2
- data transfer, 4-9
- DATECODE &&OPTIONS softkey, 2-18
- dB μ V softkey, 2-10
- dBm softkey, 2-10
- dBmV softkey, 2-10
- dc coupling, 2-10
- delimiter, 5-3
- delta marker functions, 2-65
- DEMODAGC command, 5-50
- DEMOD command, 5-48
- DEMODT command, 5-51
- DEMOD TIME softkey, 2-41, 3-12
- demodulation, 2-39, 5-48, 5-50, 5-51, 5-160
 - AM, 2-40
 - duration, 2-41
 - FM, 2-40
- demodulation functions, 5-9
- demodulation time, 5-51
- DET command, 5-53
- detection modes, 5-53
- detector mode
 - negative peak, 2-80
 - positive peak, 2-80
- detector modes, 5-92
 - normal, 2-80
 - sample, 2-80
- DETECTOR MODES softkey, 2-80
- DETECTOR NEG PEAK softkey, 2-80
- DETECTOR NORMAL softkey, 2-80
- DETECTOR POS PEAK softkey, 2-80
- DETECTOR SAMPLE softkey, 2-80
- diagnostic functions, 2-21
- diagnostics, 5-66
- digit, 5-3
- discrete Fourier transform, 2-51
- display
 - annotation, 2-84
 - focus, 2-85
 - graticule, 2-84
 - intensity, 2-84
- display adjustment, 2-20
- display aids, 5-68
- display annotation, 1-4, 5-31
- display control functions, 5-9
- display graticule, 5-77
- DISPLAY key, 2-83
- display line, 2-83, 5-55
- display origin plots, 2-16

- display origins for plotting, 5-128
- distortion
 - harmonic, 3-1
 - intermodulation, 3-7
- DL command, 5-55
- done, 5-57
- DONE command, 5-57
- DSPL LIN ON OFF softkey, 2-83
- dynamic range, 3-20
- dynamic range level, 2-8, 2-24, 2-27

E

- earphone jack, 1-6
- elapsed time, 5-60
- ELAPSED TIME softkey, 2-49
- ENTER statements, 4-3
- ERASE TITLE softkey, 2-83
- ERR command, 5-58
- error, 5-58
- error codes
 - 100 to 199, E-3
 - 200 to 299, E-5
 - 300 to 399, E-5
 - 400 to 599, E-6
 - 600 to 699, E-15
 - 800 to 899, E-17
 - 900 to 904, E-17
- automatic IF adjust, E-6
- numeric listing, E-3-17
- error message area, 1-4
- error messages, 2-49, E-1-17
- ET command, 5-60
- exchanging trace contents, 5-38
- EXIT ACP softkey, 2-57
- extended frequency range, 3-23
- external frequency reference, 2-41, 2-49
- external leveling input, 1-7
- external millimeter mixers, 3-23
- external mixer
 - preselected, 2-17
 - unpreselected, 2-17
- external mixer bands, 5-79
- external mixer bias, 2-38, 5-90
 - negative, 2-39
 - positive, 2-38
- external mixer loss compensation, 5-44
- external mixer mode, 5-61
- external mixers, 3-23
- EXTERNAL MIXER softkey, 2-33, 3-24, 3-26
- external mixing bands, 5-75, 5-81
- external mixing functions, 5-9, 5-156
- EXTERNAL softkey, 2-76
- external tracking generator functions, 2-23
- external trigger input, 1-6
- EXTMXR command, 5-61

EXT MXR PRE UNPR softkey, 2-17, 2-36

F

FA command, 5-62

FACTORY PRSEL PK softkey, 2-49

fast Fourier transform, 2-51, 5-69

FB command, 5-64

FDIAG command, 5-66

FDSP command, 5-68

FFT command, 5-69

FFT MEAS softkey, 2-51

fine tracking adjust, 5-165

firmware date code, 5-146

firmware datecode, 2-18

flatness, 2-33

flatness points, 2-34

FM DEMOD ON OFF softkey, 2-40, 3-12

FOCUS softkey, 2-85

FOFFSET command, 5-71

format TDF A, 4-16

format TDF B, 4-14

format TDF I, 4-18

format TDF M, 4-13

format TDF P, 4-12

formatting trace data, 4-11

FREE RUN softkey, 2-76

FREF command, 5-73

FREQ COUNT key, 2-67

FREQ DIAGNOSE softkey, 2-21

FREQ DSP OFF softkey, 2-85

FREQ OFFSET softkey, 2-4

frequency

modulation Bessel null, H-5

modulation carrier nulls, H-4

modulation deviation, H-5

modulation FM with incidental AM, H-6

modulation measurement, H-3

modulation sideband nulls, H-4

frequency analog voltage, 2-41

frequency annotation, 2-85

frequency bands, 2-7

frequency control functions, 5-9

frequency conversion loss, 2-34

frequency counter, 5-99

frequency counter resolution, 5-100

frequency count resolution, 2-67

frequency diagnostics, 5-66

frequency display off, 5-68

FREQUENCY key, 2-3

frequency modulation, 3-11, H-3

frequency offset, 2-4, 5-71

frequency reference, 2-41, 5-73

frequency response functions, 2-23

frequency span, 1-4, 1-10, 5-74, 5-158

frequency values, 5-3

front-panel connector data, 1-3

front-panel connectors, 1-2, 1-3

active-probe power, 1-2, 1-3

calibrator signal, 1-2, 1-3

first LO output, 1-2, 1-3

IF input, 1-2, 1-3

RF input, 1-2, 1-3

volume, 1-2, 1-3

front-panel keys, 1-8

FS command, 5-74

FULBAND command, 5-75

full Band, 5-75

FULL BAND softkey, 2-33

FULL IF ADJ softkey, 2-19

full span, 5-74

FULL SPAN softkey, 2-5

functional commands

amplitude control, 5-8

bandwidth control, 5-8

coupling control, 5-8

demodulation, 5-9

display control, 5-9

external mixing, 5-9

frequency control, 5-9

information, 5-10

instrument state, 5-10

marker control, 5-10

operator entry, 5-11

output format control, 5-11

plotter output, 5-11

preselector control, 5-11

printer output, 5-11

service diagnostics, 5-10

service requests, 5-11

sweep control, 5-12

synchronization, 5-12

trace math, 5-12

trace processing, 5-12

tracking generator, 5-13

trigger control, 5-12

user measurement, 5-13

fundamental functions, 1-1, 2-2

AMPLITUDE, 2-7

FREQUENCY, 2-3

HOLD, 2-12

SPAN, 2-5

fundamental units, 4-10

G

GRAT command, 5-77

graticule on/off, 5-77

graticule origin plots, 2-16

graticule plots, 2-16

GRAT ON OFF softkey, 2-84

H

- hardcopy devices, 2-15
- harmonic distortion, 3-1
 - alternative measurement method, 3-4
- harmonic distortion percentage, 3-6
- harmonic lock, 2-33
- harmonic number, 2-39
 - mixing, 2-39
- harmonic number lock, 5-79
- harmonic number unlock, 5-81
- HD command, 5-78
- HNLOCK command, 5-79
- HNUNLK command, 5-81
- hold, 5-78
- HOLD key, 2-12
- HP 8560A front panel, 1-1
- HP 8560A Option 002, 2-26
- HP-IB address, 4-2
 - analyzer, 2-17
 - plotter, 2-17
 - printer, 2-15
- HP-IB connector, 1-6
- HP-IB transmission data sequence, 4-19

I

- IDCF command, 5-83
- ID command, 5-82
- identification, 5-82
- IDFREQ command, 5-84
- IF ADJ ON OFF softkey, 2-19
- IF adjustment, 2-19, 5-26
- IF output, 1-7
- information and service diagnostics functions, 5-10
- initial program considerations, 4-5
- input attenuation, 5-33
- input attenuator, 2-8, 2-77
- input attenuator value, 1-5
- input connectors
 - external leveling, 1-7
 - external trigger, 1-6
 - IF, 1-2, 1-3
 - RF, 1-2, 1-3
- input coupling, 5-47
- input mixer, 5-117
- input mixer level, 2-9
- instrument calibration, 1-12
- instrument errors, 5-58
- instrument identification, 5-82
- instrument options, 2-18
- instrument preset, 4-5, 5-85
- instrument setup, adjacent channel power measurement, 2-58
- instrument state control functions, 5-10

- instrument state functions, 1-1, 2-13

- auxiliary control, 2-22
- calibration, 2-19
- configuration, 2-15
- copy, 2-43
- measure, 2-51
- module, 2-44
- preset, 2-14
- recall, 2-48
- save, 2-45
- single sweep, 2-61

INTENSTY softkey, 2-84

intermodulation distortion, 3-7

internal frequency reference, 2-41

INTERNAL MIXER softkey, 2-31

interrupt process, 4-33

IP command, 5-85

L

- LAST SPAN softkey, 2-6
- LAST STATE softkey, 2-14, 2-48
- LF with EOI, 5-3
- LG command, 5-88
- linear amplitude scale, 2-8
- linear scale, 5-89
- LINEAR softkey, 2-8
- LINE input, 1-6
- LINE softkey, 2-76
- LN command, 5-89
- LO and IF adjustments, 5-24
- LO and IF alignment routines, 2-19
- local control, 4-5
- local oscillator frequency, 2-21
- LOCK HARMONIC softkey, 2-39, 3-24
- LOCK ON OFF softkey, 2-39
- LO FREQ softkey, 2-21
- logarithmic amplitude scale, 2-8
- logarithmic scale, 5-88
- LOG dB/DIV softkey, 2-8
- LO output, first, 1-2, 1-3
- lower adjacent channel power, 5-18

M

- main roller oscillator frequency, 2-21
- MAIN ROLLER softkey, 2-21
- MAN TRK ADJ softkey, 2-29
- MARKER 1/DELTA softkey, 2-63, 2-64
- marker activation, 1-11
- marker amplitude, 5-93
- MARKER -> CF softkey, 2-65, 2-69
- MARKER -> CF STEP softkey, 2-65
- marker control functions, 5-10
- marker delta, 5-96
- MARKER DELTA, 2-64

MARKER DELTA softkey, 2-35, 2-63, 2-68,
 2-69, 3-2, 3-5, 3-8, 3-9, 3-18
 marker delta to span, 5-113
 marker frequency, 5-98
 marker functions, 1-2, 2-62
 amplitude, 5-93
 center frequency, 5-95
 center frequency step size, 5-114
 delta, 5-96
 delta to span, 5-113
 frequency, 5-98
 frequency counter, 2-67, 5-99
 frequency-counter resolution, 5-100
 marker, 2-63
 marker ->, 2-65
 marker to minimum, 5-102
 noise, 5-105
 normal, 5-103
 off, 5-106
 peak excursion, 5-110
 peak search, 2-69, 5-107
 reciprocal of marker delta, 5-97
 reference level, 5-112
 signal track, 5-116
 threshold, 5-108
 time, 5-115
 marker indicator, 1-5
 marker noise, 5-105
 marker normal, 5-103
MARKER NORMAL softkey, 2-35, 2-37, 2-40,
 2-63, 2-67, 3-12
 marker off, 5-106
 marker priority, 2-62
MARKER -> REF LVL softkey, 2-65, 3-2, 3-5,
 3-9
MARKERS OFF softkey, 2-64
 marker threshold, 5-108
 marker time, 5-115
 marker to center frequency, 5-95
 marker to center frequency step size, 5-114
 marker to minimum, 5-102
 marker to reference level, 5-112
 math commands, 4-23
 math functions, 4-23
 math commands, 4-23
 traces, 4-23
 variables, 4-23
MAX HOLD A softkey, 2-79
 maximum adjacent channel power, 5-19
 maximum hold, 5-118
 maximum signal amplitude, 2-9
MAX MXR LEVEL softkey, 2-9, 3-9
MBIAS command, 5-90
 measure adjacent channel power, 5-20
 measurements

 harmonic distortion, 3-1
 measurement techniques, 3-1
 measurement units, 4-10
 measuring harmonics, 3-4-5
MEAS/USER key, 2-51
 menus, 1-8
 menu title, 1-4
 message area, 1-5
MINH command, 5-92
 minimum hold, 5-92
 mixer bias, 5-90
 mixer level, 5-117
 mixer mode, 5-119
 mixing harmonic number, 2-39
MKA command, 5-93
MKCF command, 5-95
MKD command, 5-96
MKDR command, 5-97
MKFC command, 5-99
MKF command, 5-98
MKFRCR command, 5-100
MKMIN command, 5-102
MKN command, 5-103
MKNOISE command, 5-105
MKOFF command, 5-106
MKPK command, 5-107
MKPT command, 5-108
MKPX command, 5-110
MKR 1/Δ -> CF softkey, 2-66
MKR 1/Δ -> CF STEP softkey, 2-66
MKR -> CF STEP softkey, 3-4
MKR -> key, 2-65
MKR key, 2-63
MKRL command, 5-112
MKRNOISE ON OFF softkey, 2-64
MKR Δ -> CF softkey, 2-65
MKR Δ -> CF STEP softkey, 2-66
MKR Δ -> SPAN softkey, 2-66
MKSP command, 5-113
MKSS command, 5-114
MKT command, 5-115
MKTRACK command, 5-116
ML command, 5-117
MODULE key, 2-44
 monitoring system operation, 4-33
MXMH command, 5-118
MXRMODE command, 5-119

N

NEGATIVE BIAS softkey, 2-39
 negative-peak detector mode, 2-80
NEXT PEAK softkey, 2-36, 2-38, 2-40, 2-68,
 2-69, 3-8
NEXT PK LEFT softkey, 2-69, 3-9
NEXT PK RIGHT softkey, 2-69, 3-2, 3-9

normal detector mode, 2-80
 normalization, 3-18
 normalization routine, 2-25, 2-28, 2-80
 normalized reference level, 2-8, 5-122
 normalized reference position, 2-10, 2-25, 2-29,
 2-81, 3-18, 5-124
 normalize trace data, 5-120
 normal marker functions, 2-65
 NORMLIZE command, 5-120
 NORMLIZE ON OFF softkey, 2-25, 2-28, 2-80,
 3-18
 NORM REF LVL softkey, 2-8, 3-18, 3-19, 3-21
 NORM REF POSN softkey, 2-10, 2-25, 2-29,
 2-81, 3-18, 3-19
 note
 amplitude modulation, H-1
 incidental AM on FM signal, H-6
 signal compression, I-5
 sweep time versus bandwidth, G-4
 NRL command, 5-122
 NRPOS command, 5-124
 number, 5-3
 decimal form, 5-3
 exponential form, 5-3
 integer form, 5-3

O

offset roller oscillator frequency, 2-21
 OFFSET ROLLER softkey, 2-21
 OP command, 5-126
 open/short average calibration trace, 2-23, 2-24,
 2-27
 operation time, 5-60
 operator entry functions, 5-11
 option module connector, 1-6
 option modules, 2-44
 output
 plot, 2-43
 print, 2-43
 output connectors
 blanking, 1-6
 IF, 1-7
 sweep ramp, 1-7
 video, 1-6
 output display parameters, 5-126
 output format control functions, 5-11
 output identification, 5-82
 output power, 2-26
 OUTPUT statements, 4-3

P

parameter units, 4-10
 peak excursion, 5-110
 PEAK EXCURSN softkey, 2-70, 3-2
 peak response routine, 2-29

peak search, 5-107
 PEAK SEARCH key, 2-69
 PEAK SEARCH softkey, 2-36, 2-38, 2-40, 2-68,
 3-12
 PEAK THRESHLD softkey, 2-71
 percent of harmonic distortion, 3-6
 pictorial notation, syntax, 5-2
 plot, 2-43
 PLOT ANNOT softkey, 2-16
 PLOT command, 5-127
 PLOT GRATICUL softkey, 2-16
 PLOTORG command, 5-128
 PLOT ORG DSP GRAT softkey, 2-16, 3-4
 plot source, 5-129
 PLOTSRC command, 5-129
 PLOTTER ADDRESS softkey, 2-17
 PLOTTER CONFIG softkey, 2-16, 3-4
 plotter configuration options, 2-16
 plotter output functions, 5-11
 plotting the display, 5-127, 5-128, 5-129
 PLOT TRACE A softkey, 2-16
 PLOT TRACE B softkey, 2-16
 position units, 4-11
 POSITIVE BIAS softkey, 2-38
 positive-peak detector mode, 2-80
 POWER BANDWIDTH softkey, 2-52
 power-on register, 2-45
 POWER ON softkey, 2-48
 power transmitted, total, 5-21
 PP command, 5-131
 PRESEL AUTO PK softkey, 2-10, 2-32, 2-36
 preselected external mixing, 2-17
 preselector control functions, 5-11
 preselector DAC number, 5-134
 preselector peak, 5-131
 current data, 2-46, 2-50
 factory data, 2-47, 2-49, 2-50
 user data, 2-47, 2-50
 preselector-peak data, 2-46
 preselector peaking, 2-10, 2-32
 preselector tracking, 2-11, 2-32
 PRESEL MAN ADJ softkey, 2-11, 2-32, 2-37
 PRESEL PEAK softkey, 2-36
 PRESET key, 2-14
 print, 2-43, 5-132
 PRINT command, 5-132
 PRINT CONFIG softkey, 2-15
 PRINTER ADDRESS softkey, 2-15
 printer configuration options, 2-15
 printer options
 color printer, 2-15
 monochrome printer, 2-15
 printer output functions, 5-11
 Programming commands, 5-14
 programming techniques, 4-5

- program timing, 4-6, 5-57, 5-197
 - single-sweep mode, 4-6
 - SINGLE (sweep) softkey, 4-6
 - TS command, 4-6
- protect stored state data, 5-135
- PSDAC command, 5-134
- PSTATE command, 5-135
- pulsed RF
 - center frequency, I-2
 - desensitization, I-5
 - measurement, I-1
 - peak pulse power, I-4
 - pulse mode, I-1
 - pulse repetition interval, I-4
 - pulse width, I-3
 - side lobe ratio, I-2
- PWRBW command, 5-136
- PWR ON STATE softkey, 2-45
- PWR SWP ON OFF softkey, 2-30

Q

- query response
 - binary state value, 5-3
 - numeric value, 5-3

R

- range level, 5-147
- RANGE LVL softkey, 2-8, 2-24, 2-27, 3-19, 3-22
- RB command, 5-137
- RBR command, 5-139
- RBW/SPAN RATIO softkey, 2-75
- RCLOCAL command, 5-140
- RCLS command, 5-142
- RCLT command, 5-143
- RCLTHRU command, 5-144
- realigning LO and IF, E-1
- REALIGN LO && IF softkey, 2-19
- rear panel, 1-6
 - functions, 1-6
- REAR PANEL softkey, 2-41
- rear-panel sweep output, 2-41
- RECALL ERRORS softkey, 2-49
- recall instrument state, 5-142
- RECALL key, 2-48
- recall open/short average, 5-140
- RECALL OPN/SHRT softkey, 2-24, 2-27
- RECALL PRSEL PK softkey, 2-50
- RECALL STATE softkey, 2-48, 3-10
- recall thru, 5-144
- RECALL THRU softkey, 2-24, 2-27
- RECALL TO TR A softkey, 2-49
- RECALL TO TR B softkey, 2-49
- recall trace data, 5-143
- reciprocal of marker delta, 5-97
- reference frequency, 5-73

- reference level, 1-5, 5-112, 5-147
- reference-level amplitude, 1-11
- reference-level calibration, 1-12
- reference level calibration, 2-20, 5-149
- reference-level function, 2-7
- reference-level indicator, 1-5
- REF LVL ADJ softkey, 2-20
- REF LVL OFFSET softkey, 2-9
- REF LVL softkey, 2-7, 3-19
- remote commands
 - CLEAR statements, 4-5, 4-6
 - ENTER statements, 4-3
 - OUTPUT statements, 4-3
 - query, 4-4
 - syntax requirements, 4-4
- remote control, 4-5
- remote setup procedure, 4-2
- request service conditions, 5-151
- RES BW AUTO MAN softkey, 2-74, 2-77
- resolution bandwidth, 1-4, 2-74, 2-77, 5-137, 5-204
 - sequence, G-1
 - shape factor, G-2
 - sweep time, G-4

- resolution bandwidth to span ratio, 5-139
- REV command, 5-146
- reviewing error messages, E-2
- revision number, 5-146
- RLCAL command, 5-149
- RL command, 5-147
- ROFFSET command, 5-150
- RQS command, 5-151

S

- sample detector mode, 2-80
- SAMPLER FREQ softkey, 2-21
- sampler harmonic number, 2-21
- SAMPLER HARMONIC softkey, 2-21
- sampling oscillator frequency, 2-21
- save instrument state, 5-153
- SAVELOCK ON OFF softkey, 2-46
- SAVE PRSEL PK softkey, 2-46
- SAVES command, 5-153
- SAVE softkey, 2-45
- SAVE STATE softkey, 2-45, 3-10
- SAVET command, 5-154
- SAVE TRACE A softkey, 2-45
- SAVE TRACE B softkey, 2-46
- save trace data, 5-154
- SCREEN TITLE softkey, 2-83, 3-10
- secondary keywords, 5-5-7
- SELECT CHAR softkey, 2-83
- SER command, 5-155
- serial number, 5-155

service request, 5-174, 5-179
 service request functions, 5-11
 service-request mask, 4-34
 service requests, 4-33
 SGL SWP key, 2-61
 SIG ID AT MKR softkey, 2-31, 2-34, 3-27
 SIG ID -> CF softkey, 2-31, 2-35
 SIGID command, 5-156
 SIG ID ON OFF softkey, 2-31, 2-35, 3-26
 signal compression, 2-9, I-5
 SIGNAL IDENT, 3-26
 signal identification, 2-31, 2-35, 3-26, 5-156
 frequency, 2-31, 2-34
 harmonic number, 2-31, 2-34
 signal identification to center frequency, 5-83
 signal identified frequency, 5-84
 SIGNAL IDENT softkey, 2-34
 signal to noise density, 5-105
 signal track, 5-116
 signal tracking, 2-64
 SIG TRK ON OFF softkey, 2-64, 3-4
 SINGLE softkey, 2-73, 2-76
 single sweep, 5-157
 single-sweep mode, 2-61
 single sweep mode, 2-73, 2-76
 SNGLS command, 5-157
 softkey menu, 1-4, 1-8
 softkeys, 1-8
 SOURCE CAL MENU softkey, 2-23, 2-26, 3-17
 source leveling control, 5-162
 source power, 5-171
 source power offset, 5-167
 source power step, 5-168
 source power sweep, 5-169
 source tracking peak, 5-173
 SPACE softkey, 2-83
 SPACING/BANDWIDTH softkey, 2-56
 span, 5-113
 SPAN key, 2-5
 SPAN softkey, 2-5
 SPAN ZOOM softkey, 2-5, 3-8
 SP command, 5-158
 special function annunciators, 2-84
 special functions, 1-5
 spectrum analyzer auto-coupled sweep time,
 2-24, 2-30
 squelch, 5-160
 SQUELCH command, 5-160
 SQUELCH ON OFF softkey, 2-41
 SRCALC command, 5-162
 SRCCRSTK command, 5-163
 SRCFINTK command, 5-165
 SRCPOFS command, 5-167
 SRCPSTP command, 5-168
 SRCPSWP command, 5-169
 SRCPWR command, 5-171
 SRC PWR ON OFF softkey, 2-26, 3-14
 SRC PWR STP SIZE softkey, 2-31
 SRCTKPK command, 5-173
 SRQ command, 5-174
 SS command, 5-175
 START FREQ softkey, 2-3, 3-11
 start frequency, 1-4, 5-62
 state registers, 2-45, 2-46
 status byte query, 5-179
 STB command, 5-179
 ST command, 5-177
 step keys, 1-2
 stimulus-response, 3-13
 stimulus response mode, 2-24, 2-30
 STOP FREQ softkey, 2-3, 3-11
 stop frequency, 1-4, 5-64
 stored instrument state registers, 2-48
 store open, 5-180
 STOREOPEN command, 5-180
 store short, 5-182
 STORESHORT command, 5-182
 store thru, 5-184
 STORETHRU command, 5-184
 STORE THRU softkey, 3-17
 sweep control functions, 5-12
 sweep couple, 5-186
 SWEEP key, 2-73
 sweep modes, 5-46
 sweep output, 5-187
 sweep ramp output, 1-7
 sweep time, 1-4, 2-73, 2-77, 5-177
 SWPCPL command, 5-186
 SWP CPL SR SA softkey, 2-24, 2-30, 3-14
 SWPOUT command, 5-187
 SWP TIME AUTO MAN softkey, 2-73, 2-77
 synchronization functions, 5-12
 syntax conventions
 query responses, 5-3
 syntax diagram conventions, 5-2
 syntax elements, 5-3
 data byte, 5-3
 data byte & EOI, 5-3
 delimiter, 5-3
 digit, 5-3
 LF with EOI, 5-3
 number, 5-3
 syntax requirements, 4-4
 system communication
 remotely, 4-3
 system IF adjustment, 2-19

